



SinglFuse™ SF-0402F Series Features

- Single blow fuse for overcurrent protection
- 1005 (EIA 0402) miniature footprint
- Fast-acting fuse
- UL certified
- RoHS compliant* and halogen free
- Thin film chip fuse
- Surface mount packaging for automated assembly

SF-0402F Series - Fast Acting Surface Mount Fuses

Electrical Characteristics

Model	Rated Current (Amps)	Fusing Time	Resistance (mΩ) Typ.*	Rated Voltage	Breaking Capacity	Typical I ² t (A ² s)
SF-0402F050	0.50	Open within 1 min. at 200 % rated current	320	DC 24 V	DC24 V 35 A	0.00317
SF-0402F075	0.75		110			0.0049
SF-0402F080	0.80		120			0.00532
SF-0402F100	1.00		90			0.00724
SF-0402F125	1.25		67			0.01344
SF-0402F150	1.50		51			0.01356
SF-0402F160	1.60		46			0.01672
SF-0402F200	2.00		33			0.01983
SF-0402F250	2.50		25			0.03763
SF-0402F300	3.00		20			0.05427
SF-0402F315	3.15		19			0.06304
SF-0402F400	4.00		16			0.0896

*Resistance value was measured with less than 10 % of rated current.

Reliability Testing

Parameter	Requirement	Test Method
Carrying Capacity	No fusing	Rated current, 4 hours
Fusing Time	Within 1 minute	200 % of its rated current
Interrupting Ability	No mechanical damages	After the fuse is interrupted, rated voltage applied for 30 seconds again
Bending Test	No mechanical damages	Distance between holding points: 90 mm, Bending: 3 mm, 1 time, 30 seconds
Resistance to Solder Heat	±20 %	260 °C ±5 °C, 10 seconds ±1 second
Solderability	95 % coverage minimum	235 °C ±5 °C, 2 ±0.5 second 245 °C ±5 °C, 2 ±0.5 second (lead free)
Temperature Rise	<75 °	100 % of its rated current, measure of surface temperature
Resistance to Dry Heat	±20 %	105 °C ±5 °C, 1000 hours
Resistance to Solvent	No evident damage on protective	23 °C ±5 °C of isopropyl alcohol, 90 seconds coating and marking
Residual Resistance	10k W or more	Measure DC resistance after fusing
Thermal Shock	DR < 10 %	-20 °C / +25 °C / +125 °C / +25 °C, 10 cycles

Typical Part Marking

Represents total content. Layout may vary.



RATING CURRENT (A)	
F = 0.50	N = 1.60
• = 0.75	S = 2.00
K = 0.80	T = 2.50
L = 1.00	3 = 3.00
M = 1.25	U = 3.15
P = 1.50	W = 4.00

How to Order

SinglFuse™ Product Designator	SF - 0402 F 050 - 2
SMD Footprint	1005 (EIA 0402) size
Fuse Blow Type	F = Fast acting S = Slow blow
Rated Current	050-400 (500 mA - 4.00 A)
Packaging Type	- 2 = Tape & Reel (10,000 pcs./reel)



Asia-Pacific:

Tel: +886-2 2562-4117
Fax: +886-2 2562-4116

Europe:

Tel: +41-41 768 5555
Fax: +41-41 768 5510

The Americas:

Tel: +1-951 781-5500
Fax: +1-951 781-5700

www.bourns.com

*RoHS Directive 2002/95/EC Jan 27 2003 including Annex.

"SinglFuse" is a trademark of Bourns, Inc.

Specifications are subject to change without notice.

Customers should verify actual device performance in their specific applications

SinglFuse™ SF-0402F Series Applications

- Portable memory
- LCD monitors
- Disk drives
- PDAs
- Digital cameras
- DVDs
- Cell phones
- Rechargeable battery packs
- Battery chargers
- Set top boxes
- Industrial controllers

SF-0402F Series - Fast Acting Surface Mount Fuses BOURNS®

Solder Reflow Recommendations

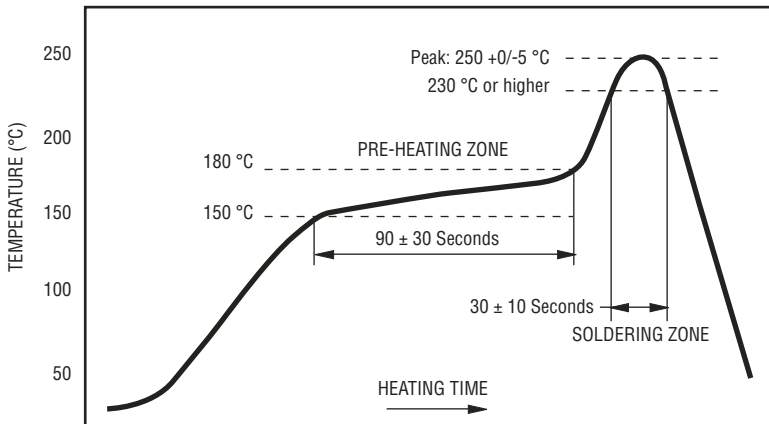

PEAK: 250 +0/-5 °C, 5 seconds
 PRE-HEATING ZONE: 150 to 180 °C, 90 ± 30 seconds
 SOLDERING ZONE: 230 °C or higher, 30 ± 10 seconds

Product Dimensions

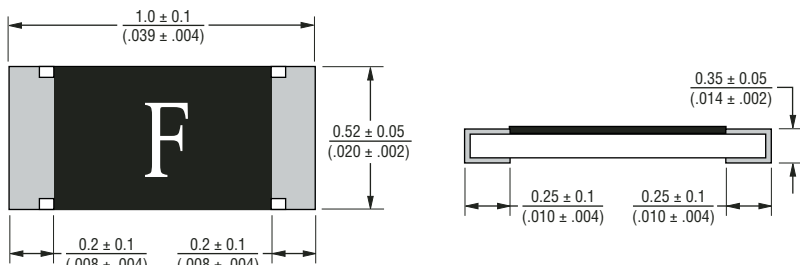

DIMENSIONS: $\frac{\text{MM}}{\text{(INCHES)}}$

PACKAGING: 10,000 pcs./reel

Recommended Pad Layout

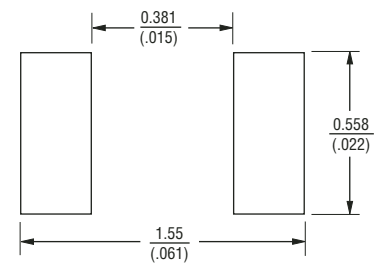

Thermal Derating Curve

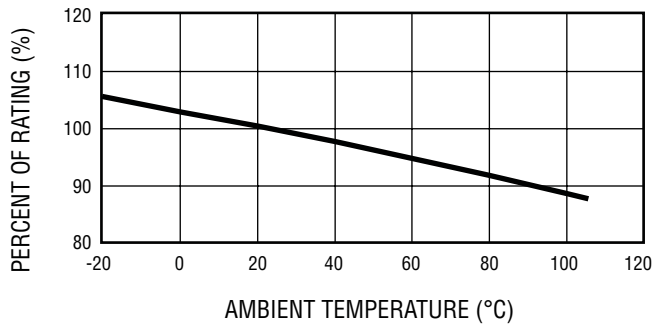

Construction & Material Content

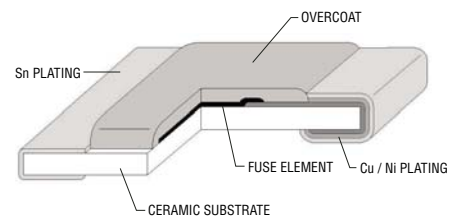

Specifications are subject to change without notice. Customers should verify actual device performance in their specific applications

SF-0402F Series - Fast Acting Surface Mount Fuses



Average Time Current Curves

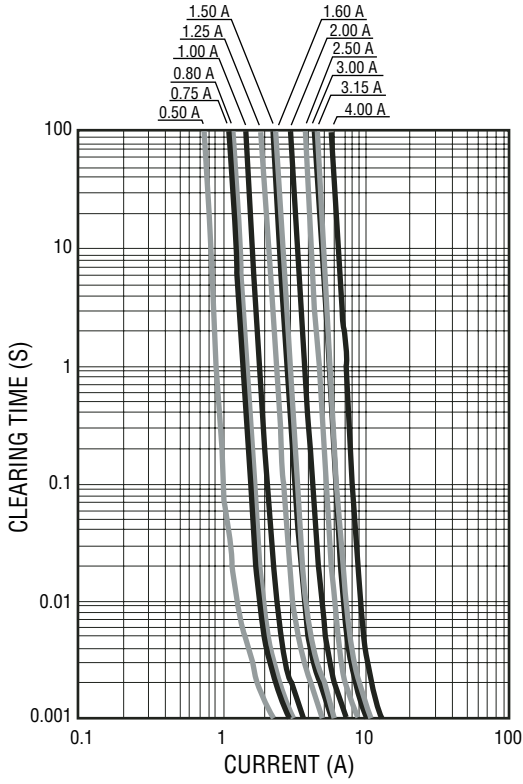

Minimum I²T V Clear Time Curves

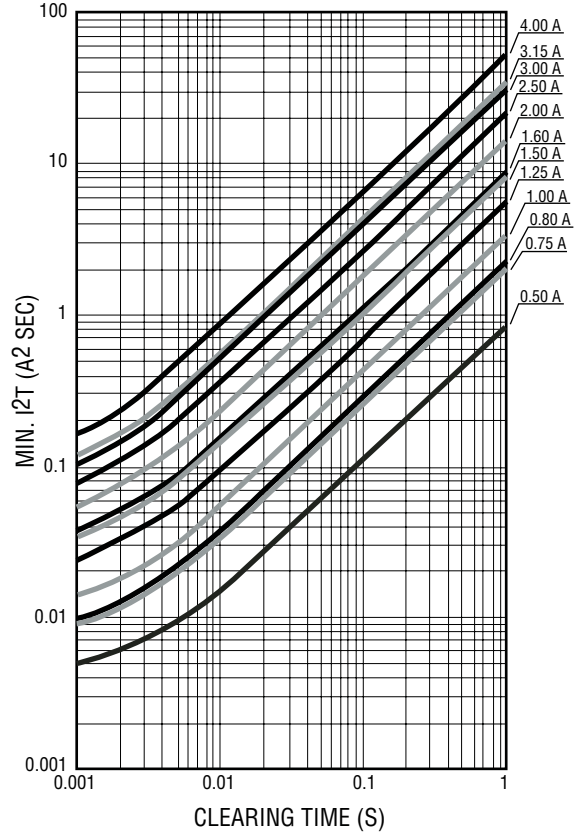

REV. B 12/08

Specifications are subject to change without notice.
Customers should verify actual device performance in their specific applications

SF-0402F Series Tape and Reel Specifications

BOURNS®

Tape Dimensions	SF-0402F Series per EIA 481-2
W	$\frac{8.0 \pm 0.2}{(.315 \pm .008)}$
P ₀	$\frac{4.0 \pm 0.1}{(.157 \pm .004)}$
P ₁	$\frac{2.0 \pm 0.1}{(.079 \pm .004)}$
P ₂	$\frac{2.0 \pm 0.05}{(.079 \pm .002)}$
A	$\frac{0.7 \pm 0.05}{(.028 \pm .002)}$
B	$\frac{1.2 \pm 0.05}{(.047 \pm .002)}$
F	$\frac{3.5 \pm 0.05}{(.138 \pm .002)}$
E	$\frac{1.75 \pm 0.1}{(.069 \pm .004)}$
D ₀	$\frac{1.5 \pm 0.1}{(.059 \pm .004)}$
T	$\frac{0.45 \pm 0.01}{(.018 \pm .004)}$
Reel Dimensions	
A	$\frac{180 +0/-3.0}{(7.087 +0/-0.118)}$
B Min.	$\frac{60.0}{(2.362)}$
C	$\frac{13.0 \pm 1.0}{(.512 \pm .039)}$
W	$\frac{9.0 \pm 1.0}{(.354 \pm .039)}$
T	$\frac{11.4 \pm 2.0}{(.449 \pm .079)}$

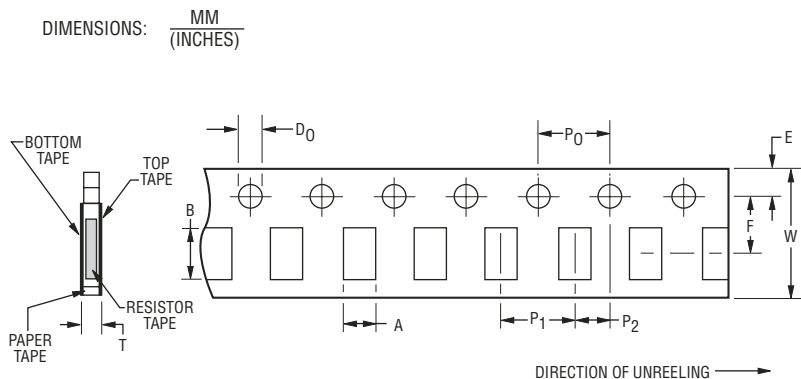
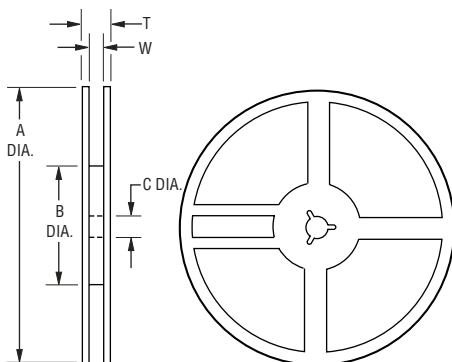

Specifications are subject to change without notice.
Customers should verify actual device performance in their specific applications