

Datamate Connectors

Datamate Trio-Tek

Female Crimp Trio-Tek

- ❖ Crimp inspection window in housing.
- ❖ Mates with Male connectors shown on pages 34 to 43.
- ❖ Contacts available separately, see page 16.
- ❖ Triangular contact design for automated assembly equipment.
- ❖ Ideal for volume applications.

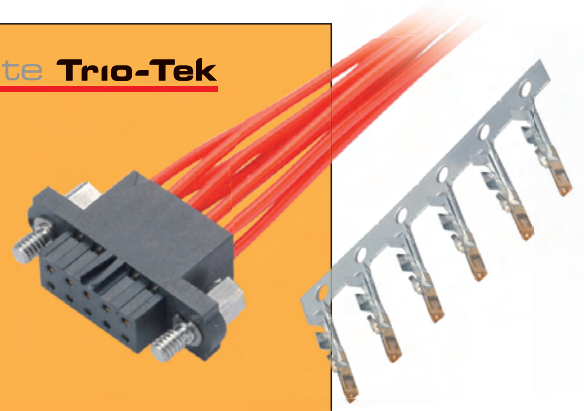

WITH JACKSCREWS

CALCULATION

A	B + 12
B	Total No. of Contacts - 2
C	B + 7

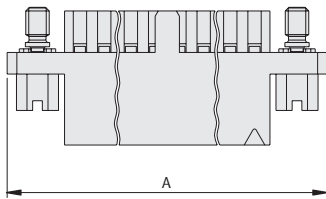
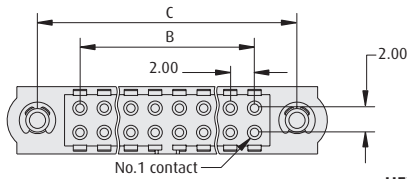

HEX SLOTTED

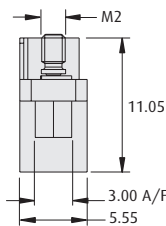

HEX SOCKET

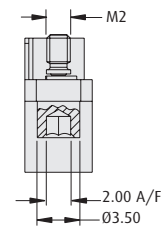

REVERSE FIX

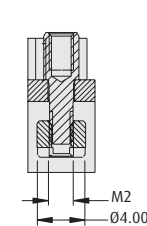

GUIDE PIN WITH PANEL MOUNT

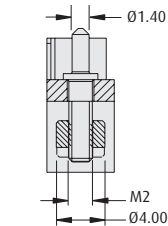

101Lok

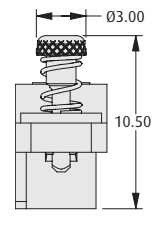

WITHOUT JACKSCREWS

TOOLS

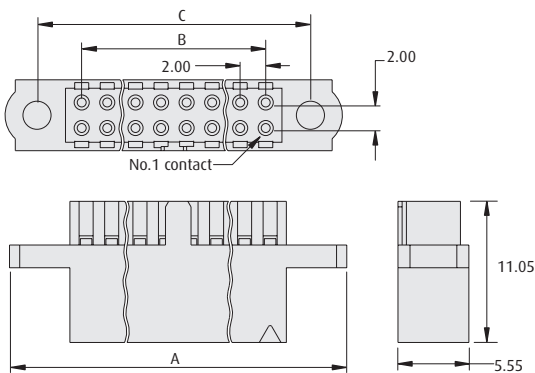

Recommended Crimp Tool - Z80-255
Contact Removal Tool - Z80-258
 See page 78
 ❖ Instruction sheets available at www.harwin.com/downloads/instructions

WIRE STRIPPING DETAILS

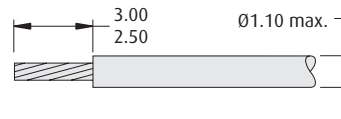

HOW TO ORDER

M80 - 45X XX XX

SERIES CODE

HOUSINGS

454	Without Jackscrews	457	Reverse Fix Jackscrews
455	Hex Slotted Jackscrews	458	Guide pin with panel mount
456	Hex Socket Jackscrews	459	101Lok jack screws

FINISH

98 Housings



TOTAL NO. OF CONTACTS

06, 08, 10, 12, 14, 20, 26, 34, 42, 50

All dimensions in mm.

www.harwin.com

