

PLEASE CHECK WWW.MOLEX.COM FOR LATEST PART INFORMATION

Part Number: [0026192131](#)
Status: **Active**
Overview: [kk](#)
Description: 3.96mm (.156") Pitch KK® Wire-to-Board Header, Vertical, Round Pin, with Polarizing Wall, 13 Circuits, Tin (Sn) Plating

Documents:

[3D Model](#) [Product Specification PS-99020-0087 \(PDF\)](#)
[Drawing \(PDF\)](#) [RoHS Certificate of Compliance \(PDF\)](#)

Agency Certification

CSA LR19980
TUV R72090224

General

Product Family PCB Headers
Series [3190](#)
Application Wire-to-Board
Overview [kk](#)
Product Name KK®

Physical

Breakaway No
Circuits (Loaded) 13
Circuits (maximum) 13
Color - Resin Natural
Durability (mating cycles max) 25
First Mate / Last Break No
Flammability 94V-2
Glow-Wire Compliant No
Guide to Mating Part No
Keying to Mating Part None
Lock to Mating Part None
Material - Metal Brass
Material - Plating Mating Tin
Material - Plating Termination Tin
Material - Resin Nylon
Number of Rows 1
Orientation Vertical
PC Tail Length (in) 0.175 In
PC Tail Length (mm) 4.45 mm
PCB Locator No
PCB Retention None
PCB Thickness Recommended (in) 0.062 In
PCB Thickness Recommended (mm) 1.60 mm
Packaging Type Bag
Pitch - Mating Interface (in) 0.156 In
Pitch - Mating Interface (mm) 3.96 mm
Plating min: Mating (µin) 200
Plating min: Mating (µm) 5
Plating min: Termination (µin) 200
Plating min: Termination (µm) 5
Polarized to PCB No
Shrouded Partial
Stackable No
Temperature Range - Operating 0°C to +75°C

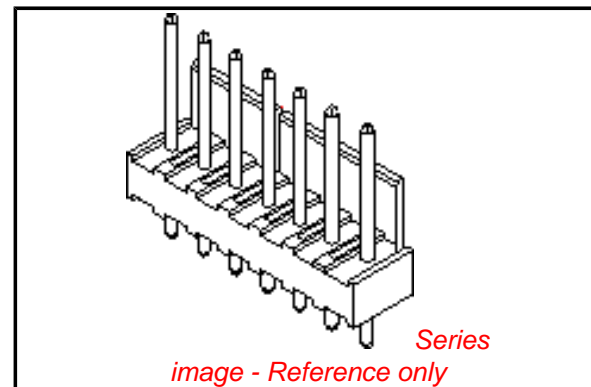

EU RoHS

ELV and RoHS Compliant
REACH SVHC
Not Reviewed
Halogen-Free Status
Not Reviewed

China RoHS



Need more information on product environmental compliance?

Email productcompliance@molex.com
For a multiple part number RoHS Certificate of Compliance, [click here](#)

Please visit the [Contact Us](#) section for any non-product compliance questions.

Search Parts in this Series

[3190Series](#)

Mates With

[3069](#) KK® Crimp Terminal Housing. [3215](#) KK® PC Board Connector

Termination Interface: Style

Through Hole

Electrical

Current - Maximum per Contact

7A

Voltage - Maximum

250V

Solder Process Data

Lead-free Process Capability

Wave Capable (TH only)

Material Info

Old Part Number

319013A

Reference - Drawing Numbers

Product Specification

PS-99020-0087

Sales Drawing

SDAE-3190-N**

This document was generated on 05/26/2010

PLEASE CHECK WWW.MOLEX.COM FOR LATEST PART INFORMATION

ENG No:	AE-3190-NA	AE-3192-NB	AE-3192-NC SEE NOTE 3	AE-3192-NH SEE NOTE 3	AE-3192-NT SEE NOTE 3	AE-3192-NS	
DIM "D"	(11.43) .450	(16.18) .637	(26.92) 1.060	(3.56) .140	(3.17) .125	(12.70) .500	
DIM "C"	(19.05) .750	(23.80) .937	(31.75) 1.250	(19.05) .750	(19.05) .750	(50.80) 2.000	
CCT SIZE	DIM "A"	DIM "B"	PART No	PART No	PART No	PART No	PART No
2	(3.96) .156	(7.92) .312	26-19-2021	26-19-2022	26-19-2023	26-19-2024	26-19-2025
3	(7.92) .312	(11.89) .468	26-19-2031	26-19-2032	26-19-2033	26-19-2034	26-19-2035
4	(11.89) .468	(15.85) .624	26-19-2041	26-19-2042	26-19-2043	26-19-2044	26-19-2045
5	(15.85) .624	(19.81) .780	26-19-2051	26-19-2052	26-19-2053	26-19-2054	26-19-2055
6	(19.81) .780	(23.77) .936	26-19-2061	26-19-2062	26-19-2063	26-19-2064	26-19-2065
7	(23.77) .936	(27.74) 1.092	26-19-2071	26-19-2072	26-19-2073	26-19-2074	26-19-2075
8	(27.74) 1.092	(31.70) 1.248	26-19-2081	26-19-2082	26-19-2083	26-19-2084	26-19-2085
9	(31.70) 1.248	(35.66) 1.404	26-19-2091	26-19-2092	26-19-2093	26-19-2094	26-19-2095
10	(35.66) 1.404	(39.62) 1.560	26-19-2101	26-19-2102	26-19-2103	26-19-2104	26-19-2105
11	(39.62) 1.560	(43.59) 1.716	26-19-2111	26-19-2112	26-19-2113	26-19-2114	26-19-2115
12	(43.59) 1.716	(47.55) 1.872	26-19-2121	26-19-2122	26-19-2123	26-19-2124	26-19-2125
13	(47.55) 1.872	(51.51) 2.028	26-19-2131	26-19-2132	26-19-2133	26-19-2134	26-19-2135
14	(51.51) 2.028	(55.47) 2.184	26-19-2141	26-19-2142	26-19-2143	26-19-2144	26-19-2145
15	(55.47) 2.184	(59.44) 2.340	26-19-2151	26-19-2152	26-19-2153	26-19-2154	26-19-2155
16	(59.44) 2.340	(63.40) 2.496	26-19-2161	26-19-2162	26-19-2163	26-19-2164	26-19-2165
17	(63.40) 2.496	(67.36) 2.652	26-19-2171	26-19-2172	26-19-2173	26-19-2174	26-19-2175
18	(67.36) 2.652	(71.32) 2.808	26-19-2181	26-19-2182	26-19-2183	26-19-2184	26-19-2185
19	(71.32) 2.808	(75.29) 2.964	26-19-2191	26-19-2192	26-19-2193	26-19-2194	26-19-2195
20	(75.29) 2.964	(79.25) 3.120	26-19-2201	26-19-2202	26-19-2203	26-19-2204	26-19-2205

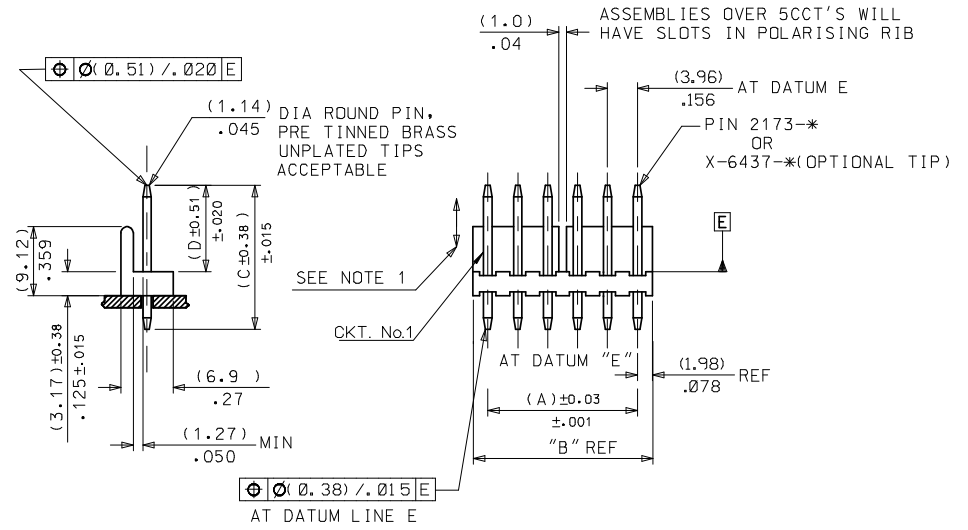

WAFER MATERIAL: NYLON 94V-2

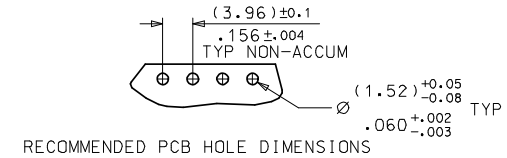

NOTES:

- PIN PUSH OUT FORCE 3 LBS MIN
- PIN MUST CONFORM TO MOLEX SOLDERABILITY SPEC No 152 AFTER PLATING
- ON THE FOLLOWING WAFERS DIM "D" IS FROM THE BOTTOM OF THE PIN TO THE BOTTOM OF THE WAFER: AE-3190-NC, AE-3190-NT, AE-3190-NH
- RECOMMENDED PCB BOARD 1.6MM

ADDED PCB NOTE EC NO: E2008-0302 DRAWN BY: DRWINLEK IERMAN DATE: 2008/02/07 CHKD: CHYK DATE: 2008/02/07 APPR: BMAGUIRE DATE: 2008/02/07	QUALITY SYMBOLS ▽=0 ▽=0	GENERAL TOLERANCES (UNLESS SPECIFIED)		DIMENSION STYLE MM ONLY		SCALE 2:1	DESIGN UNITS METRIC	THIRD ANGLE PROJECTION	
		4 PLACES ± --- INCH 3 PLACES ± --- ±.010 2 PLACES ± 0.25 ±.014 1 PLACE ± 0.35 ± ---	4 PLACES ± --- mm 3 PLACES ± --- ±.010 2 PLACES ± 0.25 ±.014 1 PLACE ± 0.35 ± ---	DRAWN BY T. MOHON	DATE 1998/10/02	CHECKED BY M. GOONEY	DATE 1998/10/02	TITLE WAFER POL KK .156 FOR .045 ROUND PINS	
DRAFT WHERE APPLICABLE MUST REMAIN WITHIN DIMENSIONS		MATERIAL NO. SEE CHART		APPROVED BY MWILHITE		DATE 1998/10/02	MOLEX INCORPORATED		
AB		REV		THIS DRAWING CONTAINS INFORMATION THAT IS PROPRIETARY TO MOLEX INCORPORATED AND SHOULD NOT BE USED WITHOUT WRITTEN PERMISSION		DOCUMENT NO. SDAE-3190-N**		SHEET NO. 1 OF 2	