



Features

- Input Internally Matched @ 50Ω
- Output Internally Matched
- 28dBm Linear Output Power
- 41% Peak Linear Efficiency - CDMA
- -51dBc ACPR @ 885kHz
- 55% AMPS Efficiency

Applications

- 3V CDMA/AMPS Cellular Handset
- 3V CDMA2000/1XRTT Cellular Handset
- 3V W-CDMA US-Cellular Handset
- 3V CDMA2000/1X-EV-DO US-Cellular Handset
- Spread-Spectrum System

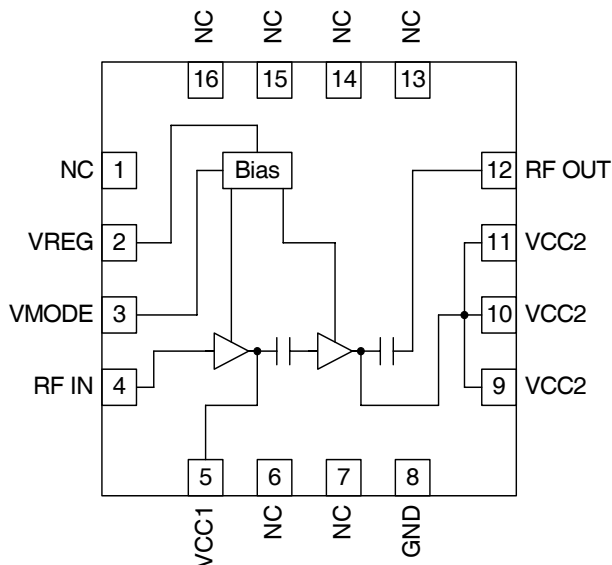

Functional Block Diagram

Product Description

The RF3163 is a high-power, high-efficiency linear amplifier module specifically designed for 3V handheld systems. The device is manufactured on an advanced third generation GaAs HBT process, and was designed for use as the final RF amplifier in 3V IS-95/CDMA2000-1X/AMPS/W-CDMA handheld digital cellular equipment, spread-spectrum systems, and other applications in the 824MHz to 849MHz band. The RF3163 has a digital control line for low power applications to lower quiescent current. The RF3163 is assembled in a 16-pin, 3mmx3mm, QFN package.

Ordering Information

RF3163 3V 900MHz Linear Power Amplifier Module
 RF3163PCBA-41X Fully Assembled Evaluation Board

Optimum Technology Matching® Applied

- | | | | |
|--|--------------------------------------|-------------------------------------|-----------------------------------|
| <input checked="" type="checkbox"/> GaAs HBT | <input type="checkbox"/> SiGe BiCMOS | <input type="checkbox"/> GaAs pHEMT | <input type="checkbox"/> GaN HEMT |
| <input type="checkbox"/> GaAs MESFET | <input type="checkbox"/> Si BiCMOS | <input type="checkbox"/> Si CMOS | |
| <input type="checkbox"/> InGaP HBT | <input type="checkbox"/> SiGe HBT | <input type="checkbox"/> Si BJT | |

RF MICRO DEVICES®, RFMD®, Optimum Technology Matching®, Enabling Wireless Connectivity™, PowerStar®, POLARIS™ TOTAL RADIO™ and UltimateBlue™ are trademarks of RFMD, LLC. BLUETOOTH is a trademark owned by Bluetooth SIG, Inc., U.S.A. and licensed for use by RFMD. All other trade names, trademarks and registered trademarks are the property of their respective owners. ©2006, RF Micro Devices, Inc.

Absolute Maximum Ratings

Parameter	Rating	Unit
Supply Voltage (RF off)	+8.0	V
Supply Voltage ($P_{OUT} \leq 31$ dBm)	+5.2	V
Control Voltage (V_{REG})	+3.9	V
Input RF Power	+10	dBm
Mode Voltage (V_{MODE})	+3.9	V
Operating Temperature	-30 to +110	°C
Storage Temperature	-40 to +150	°C
Moisture Sensitivity Level (IPC/JEDEC J-STD-20)	MSL 2 @ 260 °C	



Caution! ESD sensitive device.

Exceeding any one or a combination of the Absolute Maximum Rating conditions may cause permanent damage to the device. Extended application of Absolute Maximum Rating conditions to the device may reduce device reliability. Specified typical performance or functional operation of the device under Absolute Maximum Rating conditions is not implied.

RoHS status based on EU Directive 2002/95/EC (at time of this document revision).

The information in this publication is believed to be accurate and reliable. However, no responsibility is assumed by RF Micro Devices, Inc. ("RFMD") for its use, nor for any infringement of patents, or other rights of third parties, resulting from its use. No license is granted by implication or otherwise under any patent or patent rights of RFMD. RFMD reserves the right to change component circuitry, recommended application circuitry and specifications at any time without prior notice.

Parameter	Specification			Unit	Condition
	Min.	Typ.	Max.		
High Power Mode - CDMA (V_{MODE} Low)					T=25°C Ambient, $V_{CC}=3.4$ V, $V_{REG}=2.8$ V, $V_{MODE}=0$ V, and $P_{OUT}=28$ dBm for all parameters (unless otherwise specified).
Operating Frequency Range	824		849	MHz	
Linear Gain	26.0	28.5		dB	
Second Harmonics		-35	-30	dBc	
Third Harmonics		-40	-30	dBc	
Maximum Linear Output	28				
Linear Efficiency	37	41		%	
Maximum I_{CC}		455	501	mA	
ACPR @ 885 kHz		-51	-46	dBc	
ACPR @ 1.98 MHz		-58	-55	dBc	
Input VSWR		2:1			
Stability in Band			6:1		No oscillation > -70 dBc
Stability out of Band			10:1		No damage
Noise Power		-133		dBm/Hz	At 45 MHz offset.
Low Power Mode - CDMA (V_{MODE} High)					T=25°C Ambient, $V_{CC}=3.4$ V, $V_{REG}=2.8$ V, $V_{MODE}=2.8$ V, and $P_{OUT}=18$ dBm for all parameters (unless otherwise specified).
Operating Frequency Range	824		849	MHz	
Linear Gain	21	24		dB	
Maximum Linear Output	18				
Maximum I_{CC}		125	156	mA	$P_{OUT}=16$ dBm
ACPR @ 885 kHz		-51	-46	dBc	
ACPR @ 1.98 MHz		-61	-56	dBc	
Input VSWR		2:1			
Output VSWR Stability			6:1		No oscillation > -70 dBc
			10:1		No damage

Parameter	Specification			Unit	Condition
	Min.	Typ.	Max.		
High Power Mode - W-CDMA (V_{MODE} Low)					$T=25^{\circ}\text{C}$ Ambient, $V_{CC}=3.4\text{V}$, $V_{REG}=2.8\text{V}$, $V_{MODE}=0\text{V}$, and $P_{OUT}=28\text{dBm}$ for all parameters (unless otherwise specified).
Operating Frequency Range	824		849	MHz	
Linear Gain		28.5		dB	
Maximum Linear Output	28				
Linear Efficiency		45		%	
Maximum I_{CC}		410		mA	
ACLR @ 5MHz		-41		dBc	
ACLR @ 10MHz		-55		dBc	
Low Power Mode - W-CDMA (V_{MODE} High)					$T=25^{\circ}\text{C}$ Ambient, $V_{CC}=3.4\text{V}$, $V_{REG}=2.8\text{V}$, $V_{MODE}=2.8\text{V}$, and $P_{OUT}=18\text{dBm}$ for all parameters (unless otherwise specified).
Operating Frequency Range	824		849	MHz	
Linear Gain		24		dB	
Maximum Linear Output	18				
Maximum I_{CC}		120		mA	$P_{OUT}=16\text{dBm}$
ACLR @ 5MHz		-41		dBc	
ACLR @ 10MHz		-60		dBc	
FM Mode					$T=25^{\circ}\text{C}$ Ambient, $V_{CC}=3.4\text{V}$, $V_{REG}=2.8\text{V}$, $V_{MODE}=0\text{V}$, and $P_{OUT}=31\text{dBm}$ for all parameters (unless otherwise specified).
Operating Frequency Range	824		849	MHz	
AMPS Maximum Output Power		31		dBm	
AMPS Efficiency	48	55		%	
AMPS Gain	25.5	28			
AMPS Second Harmonics		-35	-30	dBc	
AMPS Third Harmonics		-40	-30	dBc	
Power Supply					
Supply Voltage	3.2	3.4	4.2	V	
High Gain Idle Current		55	80	mA	$V_{MODE}=\text{low}$ and $V_{REG}=2.8\text{V}$
Low Gain Idle Current		45	70	mA	$V_{MODE}=\text{high}$ and $V_{REG}=2.8\text{V}$
V_{REG} Current		4.5	5.5	mA	$V_{MODE}=\text{high}$
V_{MODE} Current		250	1000	uA	
RF Turn On/Off Time			6	uS	
DC Turn On/Off Time			40	uS	
Total Current (Power Down)		0.2	2.0	uA	
V_{REG} Low Voltage	0		0.5	V	
V_{REG} High Voltage (Recommended)	2.75	2.8	2.95	V	
V_{REG} High Voltage (Operational)	2.7		3.0	V	
V_{MODE} Voltage	0		0.5	V	High Gain Mode
	2.0		3.0	V	Low Gain Mode

Evaluation Board Schematic - CDMA

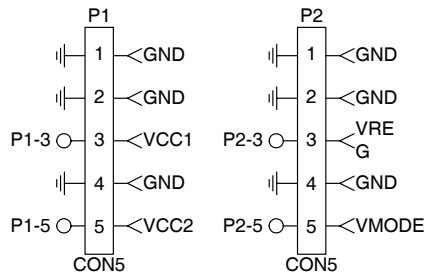
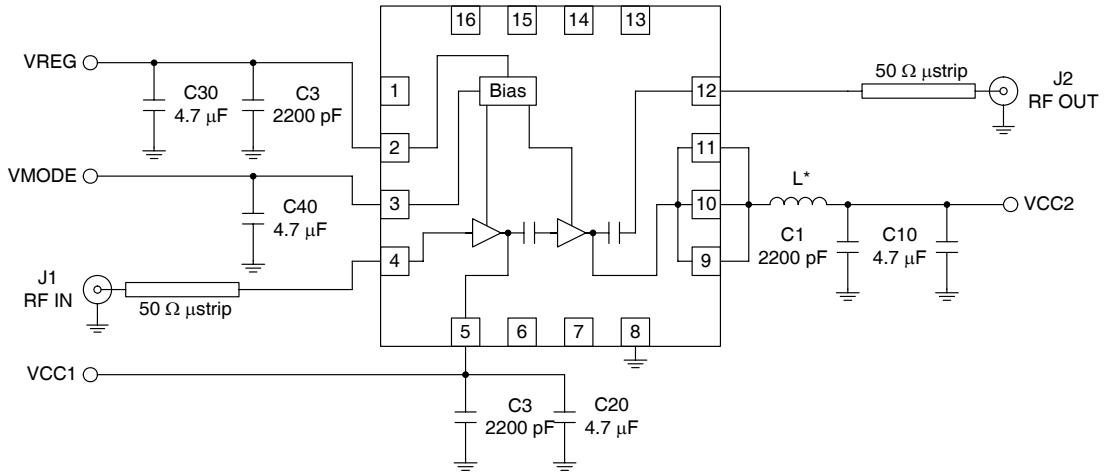

* The current rating for the inductor needs to be 1A. One example is Toko 0603 multilayer inductor with the value of 1.8 nH (Toko part number LL1608-F1N8S). The value of the inductor can be from 1.5nH to 2.2nH. Different values of the inductor will give slight shift on the tradeoff between efficiency and ACPR.

Evaluation Board Schematic - W-CDMA

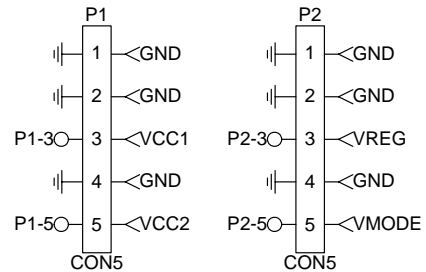
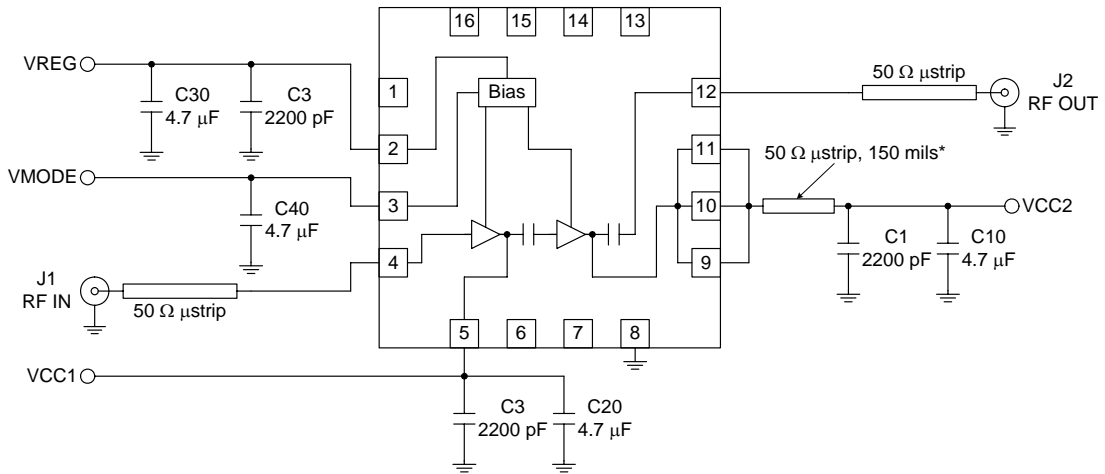

* Changing the length of this microstrip line will adjust the efficiency and ACLR trade-off.

Electrostatic Discharge Sensitivity

Human Body Model (HBM)

Figure 3 shows the HBM ESD sensitivity level for each pin to ground. The ESD test is in compliance with JESD22-A114.

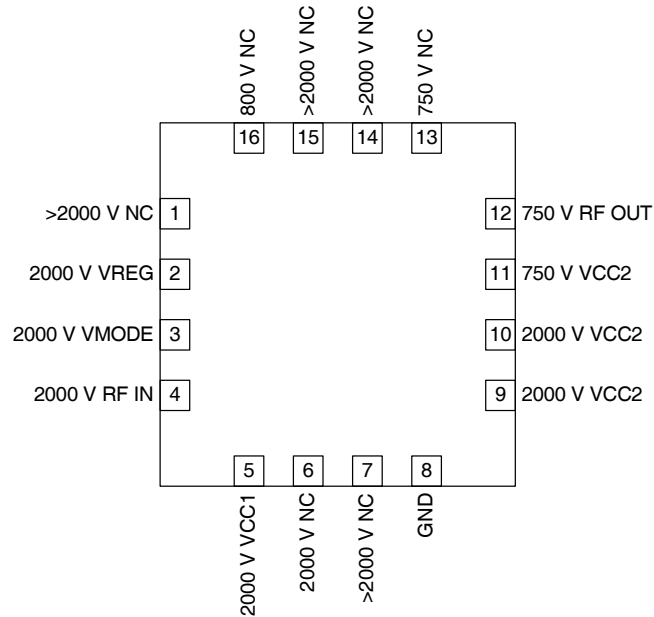

Figure 3. ESD Level - Human Body Model

Machine Model (MM)

Figure 4 shows the MM ESD sensitivity level for each pin to ground. The ESD test is in compliance with JESD22-A115.

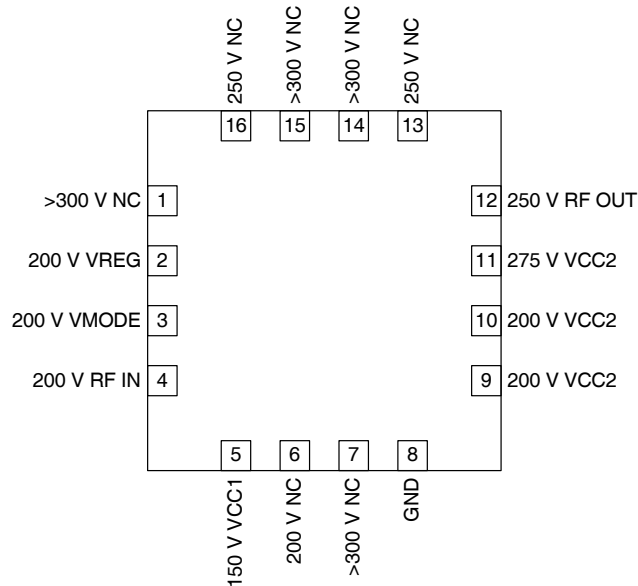

Figure 4. ESD Level - Machine Model

PCB Design Requirements

PCB Surface Finish

The PCB surface finish used for RFMD's qualification process is electroless nickel, immersion gold. Typical thickness is 3µinch to 8µinch gold over 180µinch nickel.

PCB Land Pattern Recommendation

PCB land patterns for PFMD components are based on IPC-7351 standards and RFMD empirical data. The pad pattern shown has been developed and tested for optimized assembly at RFMD. The PCB land pattern has been developed to accommodate lead and package tolerances. Since surface mount processes vary from company to company, careful process development is recommended.

PCB Metal Land Pattern

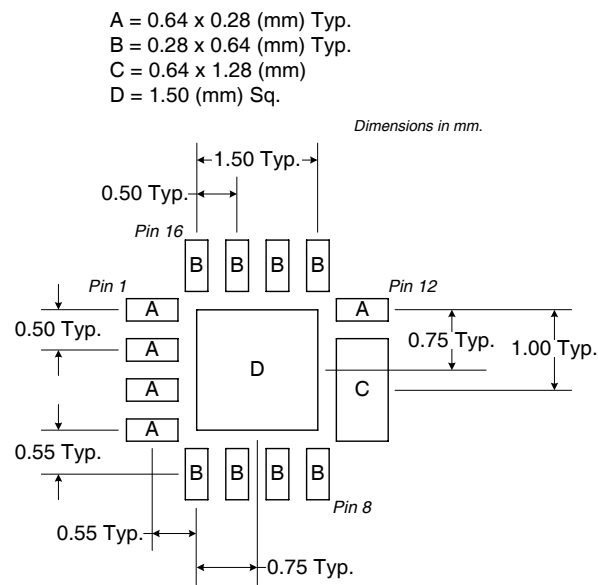

Figure 1. PCB Metal Land Pattern (Top View)

PCB Solder Mask Pattern

Liquid Photo-Imageable (LPI) solder mask is recommended. The solder mask footprint will match what is shown for the PCB metal land pattern with a 2mil to 3mil expansion to accommodate solder mask registration clearance around all pads. The center-grounding pad shall also have a solder mask clearance. Expansion of the pads to create solder mask clearance can be provided in the master data or requested from the PCB fabrication supplier.

A = 0.74 x 0.38 (mm) Typ.
 B = 0.38 x 0.74 (mm) Typ.
 C = 1.60 (mm) Sq.

Dimensions in mm.

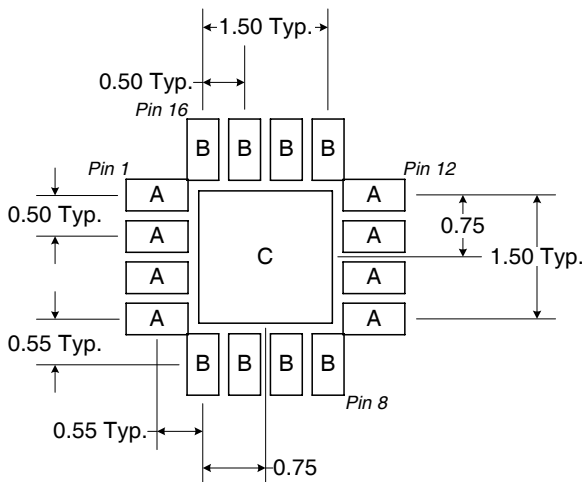

Figure 2. PCB Solder Mask Pattern (Top View)

Thermal Pad and Via Design

The PCB land pattern has been designed with a thermal pad that matches the die paddle size on the bottom of the device.

Thermal vias are required in the PCB layout to effectively conduct heat away from the package. The via pattern has been designed to address thermal, power dissipation and electrical requirements of the device as well as accommodating routing strategies.

The via pattern used for the RFMD qualification is based on thru-hole vias with 0.203mm to 0.330mm finished hole size on a 0.5mm to 1.2mm grid pattern with 0.025mm plating on via walls. If micro vias are used in a design, it is suggested that the quantity of vias be increased by a 4:1 ratio to achieve similar results.

Tape and Reel Information

Carrier tape basic dimensions are based on EIA481. The pocket is designed to hold the part for shipping and loading onto SMT manufacturing equipment, while protecting the body and the solder terminals from damaging stresses. The individual pocket design can vary from vendor to vendor, but width and pitch will be consistent.

Carrier tape is wound or placed onto a shipping reel either 330 mm (13 inches) in diameter or 178 mm (7 inches) in diameter. The center hub design is large enough to ensure the radius formed by the carrier tape around it does not put unnecessary stress on the parts.

Prior to shipping, moisture sensitive parts (MSL level 2a-5a) are baked and placed into the pockets of the carrier tape. A cover tape is sealed over the top of the entire length of the carrier tape. The reel is sealed in a moisture barrier, ESD bag, which is placed in a cardboard shipping box. It is important to note that unused moisture sensitive parts need to be resealed in the moisture barrier bag. If the reels exceed the exposure limit and need to be rebaked, most carrier tape and shipping reels are not rated as bakeable at 125 °C. If baking is required, devices may be baked according to section 4, table 4-1, column 8 of Joint Industry Standard IPC/JEDEC J-STD-033A.

The following table provides useful information for carrier tape and reels used for shipping the devices described in this document.

RFMD Part Number	Reel Diameter Inch (mm)	Hub Diameter Inch (mm)	Width (mm)	Pocket Pitch (mm)	Feed	Units per Reel
RF3163TR7	7 (178)	2.4 (61)	12	4	Single	2500

QFN (Carrier Tape Drawing with Part Orientation)

Notes:

- All dimensions are in millimeters (mm).
- Unless otherwise specified, all dimension tolerances per EIA-481.

$A_o = 3.18 \pm 0.10$
 $B_o = 3.18 \pm 0.10$
 $F = 5.50 \pm 0.05$
 $K_o = 1.02 \pm 0.10$
 $P = 4.00 \pm 0.10$
 $W = 12.00 +0.30/-0.10$

