



# TAI-SAW TECHNOLOGY CO., LTD.

No. 3, Industrial 2nd Rd., Ping-Chen Industrial District,  
Taoyuan, 324, Taiwan, R.O.C.

TEL: 886-3-4690038 FAX: 886-3-4697532

E-mail: [tstsales@mail.taisaw.com](mailto:tstsales@mail.taisaw.com) Web: [www.taisaw.com](http://www.taisaw.com)

## Approval Sheet For Product Specification

Issued Date:

Product Name: SAW Resonator 315 MHz TO-39

TST Parts No.: TC0408A

Customer Parts No.: \_\_\_\_\_

Company: _____
Division: _____
Approved by : _____
Date: _____

Checked by: Paul Ni

Approval by: Francis Chen

Date: 2007/6/25



# TAI-SAW TECHNOLOGY CO., LTD.

No. 3, Industrial 2nd Rd., Ping-Chen Industrial District,  
Taoyuan, 324, Taiwan, R.O.C.

TEL: 886-3-4690038 FAX: 886-3-4697532

E-mail: [tstsales@mail.taisaw.com](mailto:tstsales@mail.taisaw.com) Web: [www.taisaw.com](http://www.taisaw.com)

## SAW Resonator 315 MHz

MODEL NO.: TC0408A

REV. NO.:1.0

### A. FEATURES:

1. 1-Port Resonator.

### B. MAXIMUM RATING:

1. Input Power Level: 0 dBm

2. DC voltage:  $\pm 30$  V

3. Operating Temperature:  $-40^{\circ}\text{C}$  to  $+85^{\circ}\text{C}$

4. Storage Temperature:  $-40^{\circ}\text{C}$  to  $+85^{\circ}\text{C}$

### C. ELECTRICAL CHARACTERISTICS:

Characteristic	Units	Minimum	Typical	Maximum
Center frequency <b>Fr</b>	<b>MHz</b>	314.925	315.000	315.075
Insertion Loss <b>IL</b>	<b>dB</b>	-	2.0	2.5
Unloaded Q <b>QU</b>		-	16900	-
50 $\Omega$ loaded Q <b>QL</b>		-	2000	-
Frequency Aging	<b>ppm/yr</b>	-	-	10
Equivalent Elements				
Motional capacitance <b>C1</b>	<b>fF</b>	-	1.9994	-
Motional inductance <b>L1</b>	<b><math>\mu\text{H}</math></b>	-	90.67	-
Motional resistance <b>R1</b>	<b>Ohm</b>	-	19	29
Parallel capacitance <b>Co</b>	<b>pF</b>	-	4.7	-
Temp.coeff.	<b>ppm/c*2</b>	-	0.037	-
Turnover To	<b>deg.C</b>	10	25	40
Package size		TO-39		

RoHS Compliant

Lead-free soldering

### D. EQUIVIRENT CIRCUIT:

One-Port Resonator:

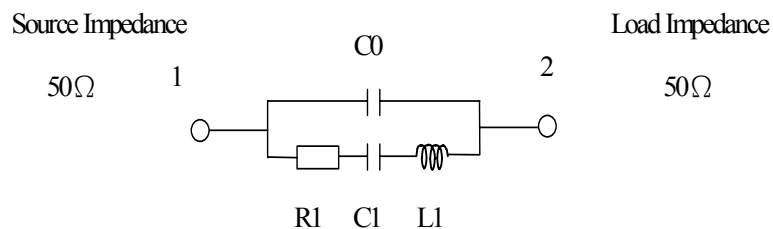

**E. OUTLINE DRAWING:**

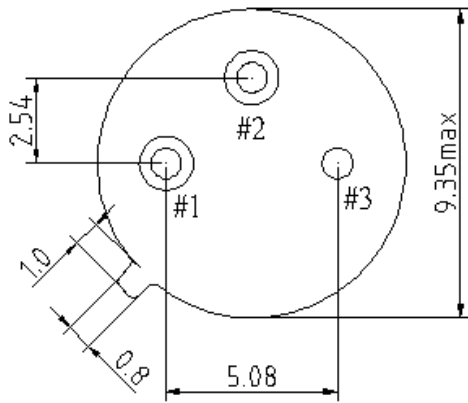
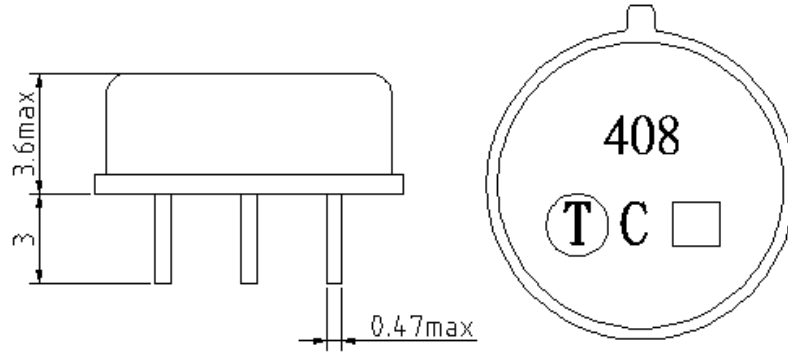

#1 : Input or Output  
 #4 : Output or Input  
 #2, 3 : Ground  
 C : Year code

Year	2001 2005	2002 2006	2003 2007	2004 2008
Product Code	C	c	<u>C</u>	<u>c</u>

□ : date code ,  
 Follow the table provided by planner each year.  
 Unit : mm

**F. FREQUENCY CHARACTERISTICS :**

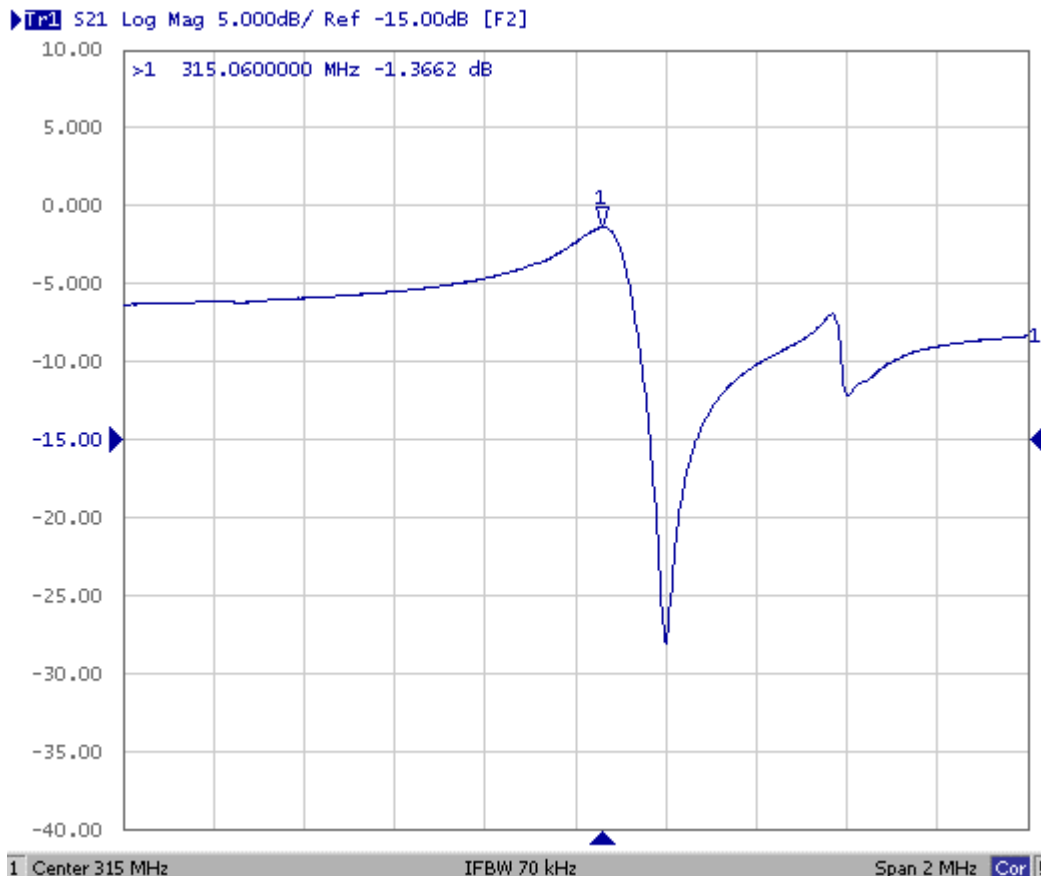

G. TEST CIRCUIT:

Network analyzer

