

**PLEASE CHECK WWW.MOLEX.COM FOR LATEST PART INFORMATION**

**Part Number:** [0330000002](#)  
**Status:** **Active**  
**Overview:** [mx150 sealed connector system](#)  
**Description:** MX150™ Male Terminal, Tin (Sn) Plating, 16-20 AWG, Right Reel Payoff, Contact Material Thickness 0.30mm (.012")

**Documents:**

[Drawing \(PDF\)](#) [RoHS Certificate of Compliance \(PDF\)](#)

**General**

Product Family	Crimp Terminals
Series	<a href="#">33000</a>
Comments	Right Reel Payoff
Crimp Quality Equipment	Yes
Overview	<a href="#">mx150 sealed connector system</a>
Product Name	MX150™

**Physical**

Gender	Male
Material - Metal	High Performance Alloy (HPA)
Material - Plating Mating	Tin
Material - Plating Termination	Tin
Packaging Type	Reel
Plating min: Mating (µin)	20
Plating min: Mating (µm)	0.5
Plating min: Termination (µin)	20
Plating min: Termination (µm)	0.5
Termination Interface: Style	Crimp or Compression
Wire Insulation Diameter	2.60mm (.102") max.
Wire Size AWG	16, 18, 20
Wire Size mm²	0.75, 1.00

**Electrical**

Current - Maximum per Contact	22A
Voltage - Maximum	250V

**Material Info**

**Reference - Drawing Numbers**

Sales Drawing	SD-33000-001
---------------	--------------



Series

*image - Reference only*

**EU RoHS**

**ELV and RoHS  
Compliant**  
**REACH SVHC  
Contains SVHC: No**  
**Halogen-Free  
Status**

**China RoHS**



**Need more information on product  
environmental compliance?**

Email [productcompliance@molex.com](mailto:productcompliance@molex.com)  
 For a multiple part number RoHS Certificate of Compliance, [click here](#)

Please visit the [Contact Us](#) section for any non-product compliance questions.

**Search Parts in this Series**

[33000Series](#)

**Use With**

[33482](#) Dual Row Housing, [33481](#) Single Row Housing, [33486](#) Hybrid Housing

**Application Tooling | FAQ**

*Tooling specifications and manuals are found by selecting the products below. Crimp Height Specifications are then contained in the Application Tooling Specification document.*

**Global**

Description	Product #
Hand Crimp Tool, 14-16AWG	<a href="#">0638112400</a>
Hand Crimp Tool, 18-22AWG	<a href="#">0638112600</a>

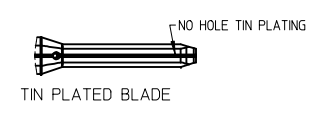
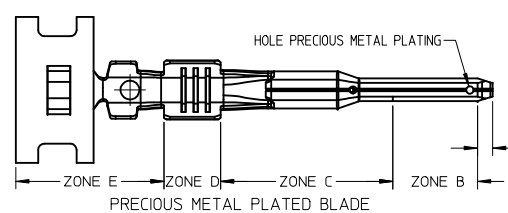
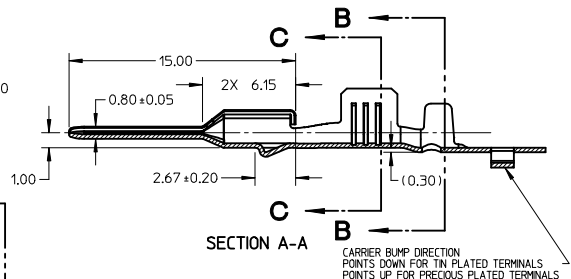
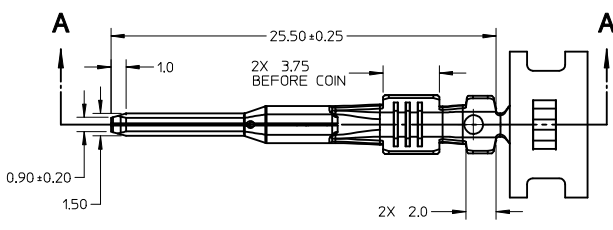
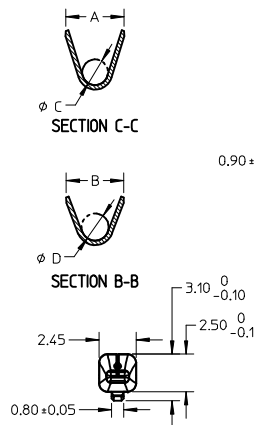
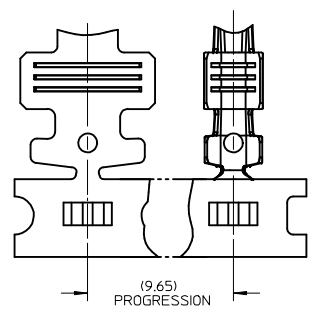
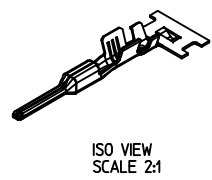
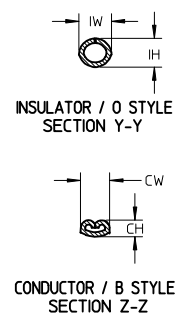
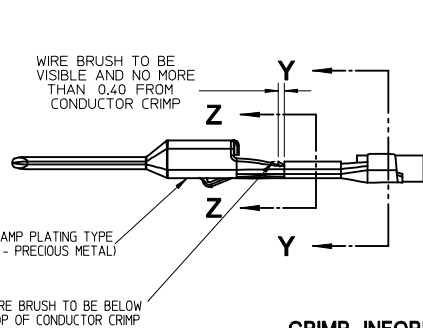

PLATING NOTES:

1. PRECIOUS METAL PLATED TERMINAL:

1.1 GOLD PLATING:

ZONE A: SHALL BE COMPLETELY COVERED WITH NICKEL TO PREVENT EXPOSED BASE METAL REDUCED GOLD THICKNESS FROM ZONE B PERMITTED

ZONE B: PRECIOUS METAL PLATING PER MOLEX PLATING SPECIFICATION ES-88

BASE LAYER: ELECTRODEPOSITED DUCTILE SULFAMATE NICKEL THICKNESS: 1.25 - 2.25 MICROMETERS

GOLD LAYER: ELECTRODEPOSITED GOLD THICKNESS: 0.76 MICROMETERS MINIMUM

ZONE C: SHALL BE COMPLETELY COVERED WITH NICKEL TO PREVENT EXPOSED BASE METAL REDUCED PLATING THICKNESS FROM ZONE B AND ZONE D PERMITTED

ZONE D: TIN PLATING PER MOLEX PLATING SPECIFICATION ES-88

BASE LAYER: ELECTRODEPOSITED DUCTILE SULFAMATE NICKEL THICKNESS: 1.25 - 2.25 MICROMETERS

TIN LAYER: ELECTRODEPOSITED 100% TIN, MATTE FINISH THICKNESS: 2.5 - 4.0 MICROMETERS

ZONE E: SHALL BE COMPLETELY COVERED WITH NICKEL TO PREVENT EXPOSED BASE METAL REDUCED THICKNESS FROM ZONE D PERMITTED

1.2 SILVER PLATING:

ZONE A: SHALL BE COMPLETELY COVERED WITH NICKEL TO PREVENT EXPOSED BASE METAL REDUCED SILVER THICKNESS FROM ZONE B PERMITTED

ZONE B: SILVER PLATING

BASE LAYER: ELECTRODEPOSITED DUCTILE SULFAMATE NICKEL THICKNESS: 1.25 - 2.25 MICROMETERS

SILVER LAYER: ELECTRODEPOSITED PURE SILVER (0.5% MAX IMPURITIES) THICKNESS: 1.9 - 3.3 MICROMETERS FINISH: SEMI BRIGHT

ANTI-TARNISH: TREATMENT FOR SILVER PLATED TERMINAL - EVABRITE WS

ZONE C: SHALL BE COMPLETELY COVERED WITH NICKEL TO PREVENT EXPOSED BASE METAL REDUCED PLATING THICKNESS FROM ZONE B AND ZONE D PERMITTED

ZONE D: TIN PLATING PER MOLEX PLATING SPECIFICATION ES-88

BASE LAYER: ELECTRODEPOSITED DUCTILE SULFAMATE NICKEL THICKNESS 1.25 - 2.25 MICROMETERS

TIN LAYER: ELECTRODEPOSITED 100% TIN, MATTE FINISH THICKNESS 2.5 - 4.0 MICROMETERS

ZONE E: SHALL BE COMPLETELY COVERED WITH NICKEL TO PREVENT EXPOSED BASE METAL REDUCED THICKNESS FROM ZONE D PERMITTED

2. TIN PLATED TERMINAL (ENTIRE TERMINAL)

BASE LAYER: ELECTRODEPOSITED ADVANCED TIN BARRIER THICKNESS 0.25 - 1.00 MICROMETERS

TIN LAYER: ELECTRODEPOSITED REFLOW TIN, 100% TIN, NO BRIGHTENERS THICKNESS 0.50 - 1.00 MICROMETERS

GENERAL NOTES: (UNLESS OTHERWISE SPECIFIED)

- MATING TERMINAL SHOWN ON SD-33012-002
- MATERIAL: ASTM B422, UNS C19025, HR04 THICKNESS: 0.30 mm ±0.01 TEMPER: FULL HARD (REF) TENSILE: 496-572 MPA PLATING: SEE PLATING NOTES
- MEETS CRIMP PERFORMANCE SPECIFICATION SAE/USCAR-21 (RELEASED: 08/25/01)
- MEETS PERFORMANCE STANDARD FOR AUTOMOTIVE ELECTRICAL CONNECTOR SYSTEMS SAE/USCAR-2 REV 3 (APRIL 2001)
- MEETS FIELD CORRELATED LIFE TEST SAE/USCAR-20 (NOVEMBER 2001)
- MEETS WIRING COMPONENT DESIGN GUIDELINES SAE/USCAR-12 REV 2 (DECEMBER 2001)
- MEETS ELECTRICAL CONNECTION SYSTEM DESIGN SPECIFICATION (SDS) REV 11 (5/2002)
- REFERENCE PK-31300-516 FOR REEL DIRECTION
- REFERENCE CS-33000-001 FOR ADDITIONAL CRIMP INFORMATION

<b>ENTER DESCRIPTION</b> EC NO: UAU2010-0107 DRINKFERGUSON 2009/08/18 CHKD:A.DHIR 2009/08/19 APPR:BMOSER 2009/08/20	<b>QUALITY SYMBOLS</b> ▽=0 ▽=0	<b>GENERAL TOLERANCES (UNLESS SPECIFIED)</b>		<b>DIMENSION STYLE</b> MM ONLY	<b>SCALE</b> 4:1	<b>DESIGN UNITS</b> METRIC	THIRD ANGLE PROJECTION		
		4 PLACES ± --- ± --- 3 PLACES ± --- ± --- 2 PLACES ± 0.1 ± --- 1 PLACE ± 0.3 ± ---	mm      INCH	DRAWN BY DATE L.PULLIAM 2006/01/31	CHECKED BY DATE A.DHIR 2006/02/01	<b>MX150 15MM BLADE TERMINAL</b>			
		ANGULAR ± 3 °		APPROVED BY DATE B.MOSER 2006/02/02	<b>MOLEX MOLEX INCORPORATED</b>				
		<b>REV</b> C10	<b>DESCRIPTION</b>	MATERIAL NO. <b>SEE TABLE</b>	DOCUMENT NO. SD-33000-001	SHEET NO. 1 OF 5			

SUPPLIER PART NO.		FORD PART NO.	PLATING (STAMPING)	WIRE APPLICATION			A +0.30	B +0.30	C +0.30	D +0.30	E +0.005	F +0.005	G +0.005	J +0.005	K +0.005	M +0.005	N +0.005	P +0.005	R +0.005	U +0.005	V +0.005	
B DIRECTION RIGHT PAYOFF	D DIRECTION LEFT PAYOFF			SAE (awg)	WIRE SPECIFICATION	METRIC (mm)																WIRE SPECIFICATION
33000-0001	33000-1001	ZL1T-14421-DA	TIN	14	MIL-123A/MIL-135A1	2.0, 1.5	MIL-126A1 JASO D 611	3.9	3.8	1.7	1.6	12.82	0.60	1.19	7.05	13.12	1.35	6.91	2.44	6.11	2.72	1.40
33000-0002	33000-1002	ZL1T-14421-CA	TIN	16	MIL-123A	-		3.3	3.1	1.3	1.4	12.46	0.57	0.99	6.52	12.96	1.28	6.51	2.14	1.93	2.52	1.30
				18	MIL-123A	10, 0.75	MIL-126A1	3.3	3.1	1.3	1.4	12.46	0.57	0.99	6.52	12.96	1.28	6.51	2.14	1.93	2.52	1.30
				20	SAE J1128 (IGXL)	-		3.3	3.1	1.3	1.4	12.46	0.57	0.99	6.52	12.96	1.28	6.51	2.14	1.93	2.52	1.30
33000-0003	33000-1003	ZL1T-14421-BA	TIN	22	MIL-123A	0.5	MIL-126A1 JASO D 611	2.5	2.6	0.9	1.0	11.97	0.42	0.72	6.57	12.24	0.93	6.31	1.60	1.44	1.84	0.95
33000-0003*	33000-1003*	ZL1T-14421-BA*	TIN	-		0.35	WSK-1A348-A2	2.5	2.6	0.9	1.0	11.97	0.42	0.72	6.57	12.24	0.93	6.31	1.60	1.44	1.84	0.95
33000-0024*	33000-1024*	4L2T-14421-AA*	TIN	-		0.35 + 0.35	MIL-126A1	T80	T80	T80	T80	T80	T80	T80	T80	T80	T80	T80	T80	T80	T80	T80
33000-0024*	33000-1024*	4L2T-14421-AA*	TIN	-		0.35 + 0.50	MIL-126A1	T80	T80	T80	T80	T80	T80	T80	T80	T80	T80	T80	T80	T80	T80	T80
33011-1002	33011-0002	ZL1T-14421-GA	GOLD	14	MIL-123A/MIL-135A1	2.0, 1.5	MIL-126A1 JASO D 611	3.9	3.8	1.7	1.6	12.82	0.60	1.19	7.05	13.12	1.35	6.91	2.44	6.11	2.72	1.40
33011-1004	33011-0004	ZL1T-14421-FA	GOLD	16	MIL-123A	-		3.3	3.1	1.3	1.4	12.46	0.57	0.99	6.52	12.96	1.28	6.51	2.14	1.93	2.52	1.30
				18	MIL-123A	10, 0.75	MIL-126A1	3.3	3.1	1.3	1.4	12.46	0.57	0.99	6.52	12.96	1.28	6.51	2.14	1.93	2.52	1.30
				20	SAE J1128 (IGXL)	-		3.3	3.1	1.3	1.4	12.46	0.57	0.99	6.52	12.96	1.28	6.51	2.14	1.93	2.52	1.30
33011-1006	33011-0006	ZL1T-14421-EA	GOLD	22	MIL-123A	0.5	MIL-126A1 JASO D 611	2.5	2.6	0.9	1.0	11.97	0.42	0.72	6.57	12.24	0.93	6.31	1.60	1.44	1.84	0.95
33011-1006*	33011-0006*	ZL1T-14421-EA*	GOLD	-		0.35	WSK-1A348-A2	2.5	2.6	0.9	1.0	11.97	0.42	0.72	6.57	12.24	0.93	6.31	1.60	1.44	1.84	0.95
33011-2003	33011-3003	7U5T-14421-CA	SILVER	14	MIL-123A/MIL-135A1	2.0, 1.5	MIL-126A1 JASO D 611	3.9	3.8	1.7	1.6	12.82	0.60	1.19	7.05	13.12	1.35	6.91	2.44	6.11	2.72	1.40
33011-2002	33011-3002	7U5T-14421-BA	SILVER	16	MIL-123A	-		3.3	3.1	1.3	1.4	12.46	0.57	0.99	6.52	12.96	1.28	6.51	2.14	1.93	2.52	1.30
				18	MIL-123A	10, 0.75	MIL-126A1	3.3	3.1	1.3	1.4	12.46	0.57	0.99	6.52	12.96	1.28	6.51	2.14	1.93	2.52	1.30
				20	SAE J1128 (IGXL)	-		3.3	3.1	1.3	1.4	12.46	0.57	0.99	6.52	12.96	1.28	6.51	2.14	1.93	2.52	1.30
33011-2001	33011-3001	7U5T-14421-AA	SILVER	22	MIL-123A	0.5	MIL-126A1 JASO D 611	2.5	2.6	0.9	1.0	11.97	0.42	0.72	6.57	12.24	0.93	6.31	1.60	1.44	1.84	0.95
33011-2001*	33011-3001*	7U5T-14421-AA*	SILVER	-		0.35	WSK-1A348-A2	2.5	2.6	0.9	1.0	11.97	0.42	0.72	6.57	12.24	0.93	6.31	1.60	1.44	1.84	0.95

\* UNSEALED APPLICATIONS ONLY

TABLE 1 - TERMINAL CRIMP DIMENSIONS REFERENCE TABLE

SUPPLIER PART NO.	FORD PART NO.	PLATING	WIRE SIZE	WIRE SPECIFICATION	CONDUCTOR CH (SECT Z-Z) +0.05 mm	CONDUCTOR CW (SECT Z-Z) +0.10 mm	INSULATOR IH (SECT Y-Y) +0.10 mm	INSULATOR IW (SECT Y-Y) +0.10 mm	WIRE PULL FORCE (N)	
33000-0001	33000-1001	ZL1T-14421-DA	TIN	14 awg	MIL-123A	1.65	2.45	2.85	2.75	339
				MIL-135A1	1.65	2.45	2.80	2.80	339	
33000-0002	33000-1002	ZL1T-14421-CA	TIN	16 awg	MIL-123A	1.35	2.15	2.20	2.60	215
				18 awg	SAE J1128 (IGXL)	1.25	2.15	2.30	2.60	158
				20 awg	MIL-123A	1.15	2.15	1.90	2.10	113
33000-0003	33000-1003	ZL1T-14421-BA	TIN	22 awg	MIL-123A	1.00	1.60	1.85	1.90	62
33000-0001	33000-1001	ZL1T-14421-DA	TIN	2.0 mm <sup>2</sup>	JASO D 611 (AVSSI)	1.60	2.45	2.85	2.75	233
33000-0002	33000-1002	ZL1T-14421-CA	TIN	1.5 mm <sup>2</sup>	MIL-126A1	1.40	2.45	2.65	2.80	177
				0.75 mm <sup>2</sup>	MIL-126A1	1.30	2.15	2.00	2.30	162
				MIL-126A1	1.25	2.15	1.95	2.30	145	
33000-0003	33000-1003	ZL1T-14421-BA	TIN	0.5 mm <sup>2</sup>	MIL-126A1	1.10	1.60	1.80	1.90	82
33000-0003*	33000-1003*	ZL1T-14421-BA*	TIN	0.35 mm <sup>2</sup>	JASO D 611 (AVSSI)	1.10	1.60	1.85	1.90	100
33000-0024*	33000-1024*	4L2T-14421-AA*	TIN	0.35 + 0.35	WSK-1A348-A2	0.95	1.60	1.70	1.90	50
33000-0024*	33000-1024*	4L2T-14421-AA*	TIN	0.35 + 0.50	MIL-126A1	T80	T80	T80	T80	T80
33011-1002	33011-0002	ZL1T-14421-GA	GOLD	14 awg	MIL-123A	1.65	2.45	2.85	2.75	339
				MIL-135A1	1.65	2.45	2.80	2.80	339	
33011-1004	33011-0004	ZL1T-14421-FA	GOLD	16 awg	MIL-123A	1.35	2.15	2.20	2.60	215
				18 awg	MIL-123A	1.25	2.15	2.00	2.30	157
				20 awg	SAE J1128 (IGXL)	1.25	2.15	2.30	2.60	158
33011-1006	33011-0006	ZL1T-14421-EA	GOLD	22 awg	MIL-123A	1.00	1.60	1.85	1.90	62
33011-1002	33011-0002	ZL1T-14421-GA	GOLD	2.0 mm <sup>2</sup>	JASO D 611 (AVSSI)	1.60	2.45	2.85	2.75	233
33011-1004	33011-0004	ZL1T-14421-FA	GOLD	1.5 mm <sup>2</sup>	MIL-126A1	1.40	2.45	2.65	2.80	177
				0.75 mm <sup>2</sup>	MIL-126A1	1.30	2.15	2.00	2.30	162
				MIL-126A1	1.25	2.15	1.95	2.30	145	
33011-1006	33011-0006	ZL1T-14421-EA	GOLD	0.5 mm <sup>2</sup>	MIL-126A1	1.10	1.60	1.80	1.90	82
33011-1006*	33011-0006*	ZL1T-14421-EA*	GOLD	0.35 mm <sup>2</sup>	JASO D 611 (AVSSI)	1.10	1.60	1.85	1.90	100
33011-2003	33011-3003	7U5T-14421-CA	SILVER	14 awg	MIL-123A	1.65	2.45	2.85	2.75	339
33011-2002	33011-3002	7U5T-14421-BA	SILVER	16 awg	MIL-135A1	1.65	2.45	2.80	2.80	339
				18 awg	MIL-123A	1.35	2.15	2.20	2.60	215
				20 awg	SAE J1128 (IGXL)	1.25	2.15	2.30	2.60	158
33011-2001	33011-3001	7U5T-14421-AA	SILVER	22 awg	MIL-123A	1.00	1.60	1.85	1.90	62
33011-2003	33011-3003	7U5T-14421-CA	SILVER	2.0 mm <sup>2</sup>	JASO D 611 (AVSSI)	1.60	2.45	2.85	2.75	233
33011-2002	33011-3002	7U5T-14421-BA	SILVER	1.5 mm <sup>2</sup>	MIL-126A1	1.40	2.45	2.65	2.80	177
				0.75 mm <sup>2</sup>	MIL-126A1	1.30	2.15	2.00	2.30	162
				MIL-126A1	1.25	2.15	1.95	2.30	145	
33011-2001	33011-3001	7U5T-14421-AA	SILVER	0.5 mm <sup>2</sup>	MIL-126A1	1.10	1.60	1.80	1.90	82
33011-2001*	33011-3001*	7U5T-14421-AA*	SILVER	0.35 mm <sup>2</sup>	JASO D 611 (AVSSI)	1.10	1.60	1.85	1.90	100

\* UNSEALED APPLICATIONS ONLY

ENTER DESCRIPTION  
 EC NO: UAU2010-0107  
 DRANKFERGUSON 2009/08/18  
 CHKD-A.DHIR 2009/08/19  
 APPR-BMOSER 2009/08/20  
 REV

QUALITY SYMBOLS  
 ▽=0  
 ▽=0  
 C10

GENERAL TOLERANCES (UNLESS SPECIFIED)

	mm	INCH
4 PLACES ±	± ---	± ---
3 PLACES ±	± ---	± ---
2 PLACES ±	± 0.1	± ---
1 PLACE ±	± 0.3	± ---

ANGULAR ± 3°

DRAFT WHERE APPLICABLE  
 MUST REMAIN WITHIN DIMENSIONS

DIMENSION STYLE  
**MM ONLY**

DRAWN BY DATE  
 L.PULLIAM 2006/01/31

CHECKED BY DATE  
 A.DHIR 2006/02/01

APPROVED BY DATE  
 B.MOSER 2006/02/02

MATERIAL NO.  
**9999999999**

SCALE  
**1:1**

DESIGN UNITS  
**METRIC**

THIRD ANGLE PROJECTION

TITLE  
**MX150 15MM BLADE TERMINAL**

**molex** MOLEX INCORPORATED

DOCUMENT NO.  
**SD-33000-001**

SHEET NO.  
**2 OF 5**

THIS DRAWING CONTAINS INFORMATION THAT IS PROPRIETARY TO MOLEX INCORPORATED AND SHOULD NOT BE USED WITHOUT WRITTEN PERMISSION

**CRIMP TOOL INFORMATION  
EXCEPT 14 GA**

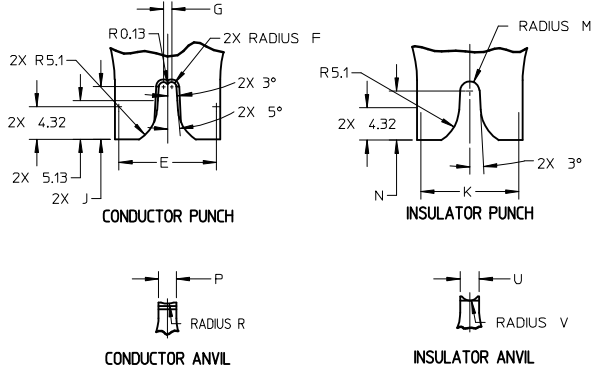

**14 GA CRIMP TOOLING**

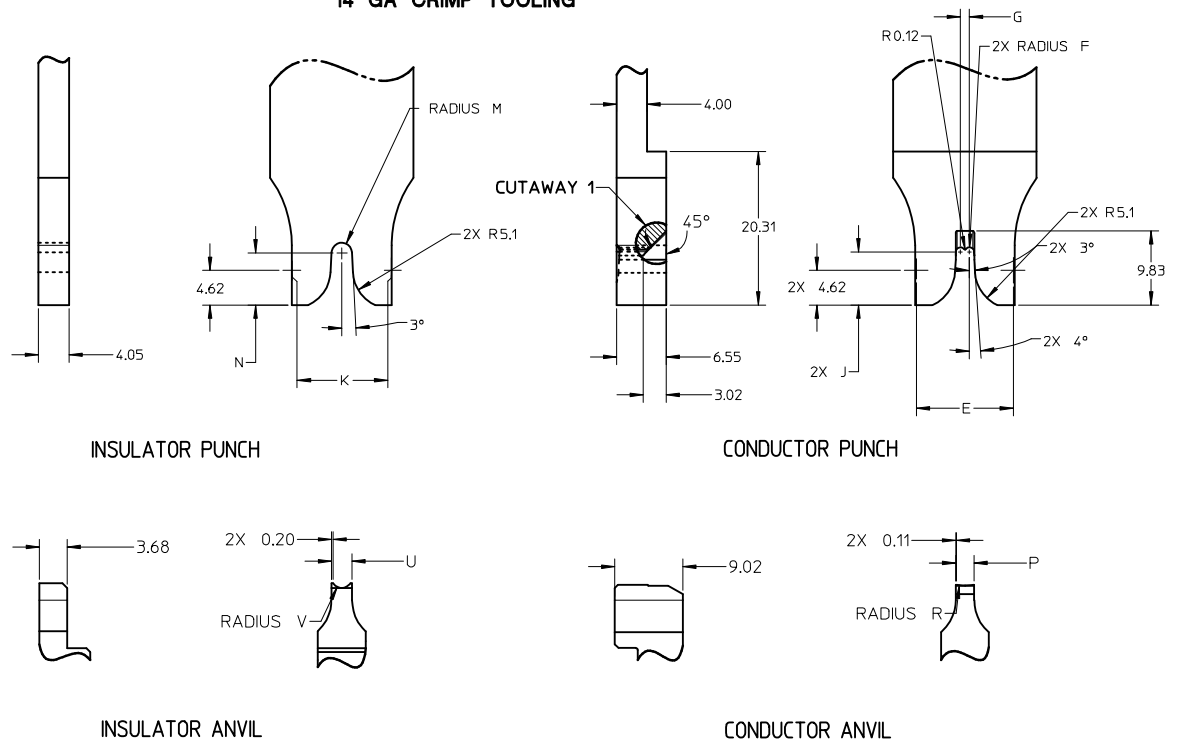

<b>ENTER DESCRIPTION</b> EC NO: UAU2010-0107 DRWNG:FERGUSON 2009/08/18 CHKD:A.DHIR 2009/08/19 APPR:BMOSER 2009/08/20 REV	QUALITY SYMBOLS ▽=0 ▽=0	GENERAL TOLERANCES (UNLESS SPECIFIED) <table border="1"> <tr> <th></th> <th>mm</th> <th>INCH</th> </tr> <tr> <td>4 PLACES</td> <td>± .005</td> <td>± .0004</td> </tr> <tr> <td>3 PLACES</td> <td>± .008</td> <td>± .0003</td> </tr> <tr> <td>2 PLACES</td> <td>± 0.1</td> <td>± .0039</td> </tr> <tr> <td>1 PLACE</td> <td>± 0.3</td> <td>± .0118</td> </tr> </table>		mm	INCH	4 PLACES	± .005	± .0004	3 PLACES	± .008	± .0003	2 PLACES	± 0.1	± .0039	1 PLACE	± 0.3	± .0118	DIMENSION STYLE <b>MM ONLY</b> DRAWN BY DATE L.PULLIAM 2006/01/31 CHECKED BY DATE A.DHIR 2006/02/01 APPROVED BY DATE B.MOSER 2006/02/02	SCALE <b>2:1</b> DESIGN UNITS <b>METRIC</b> THIRD ANGLE PROJECTION	TITLE <b>MX150 15MM BLADE TERMINAL</b>
		mm	INCH																	
	4 PLACES	± .005	± .0004																	
	3 PLACES	± .008	± .0003																	
2 PLACES	± 0.1	± .0039																		
1 PLACE	± 0.3	± .0118																		
MATERIAL NO. <b>SEE TABLE</b>	DOCUMENT NO. <b>SD-33000-001</b>	SHEET NO. <b>3 OF 5</b>																		
SIZE <b>C10</b>	THIS DRAWING CONTAINS INFORMATION THAT IS PROPRIETARY TO MOLEX INCORPORATED AND SHOULD NOT BE USED WITHOUT WRITTEN PERMISSION																			

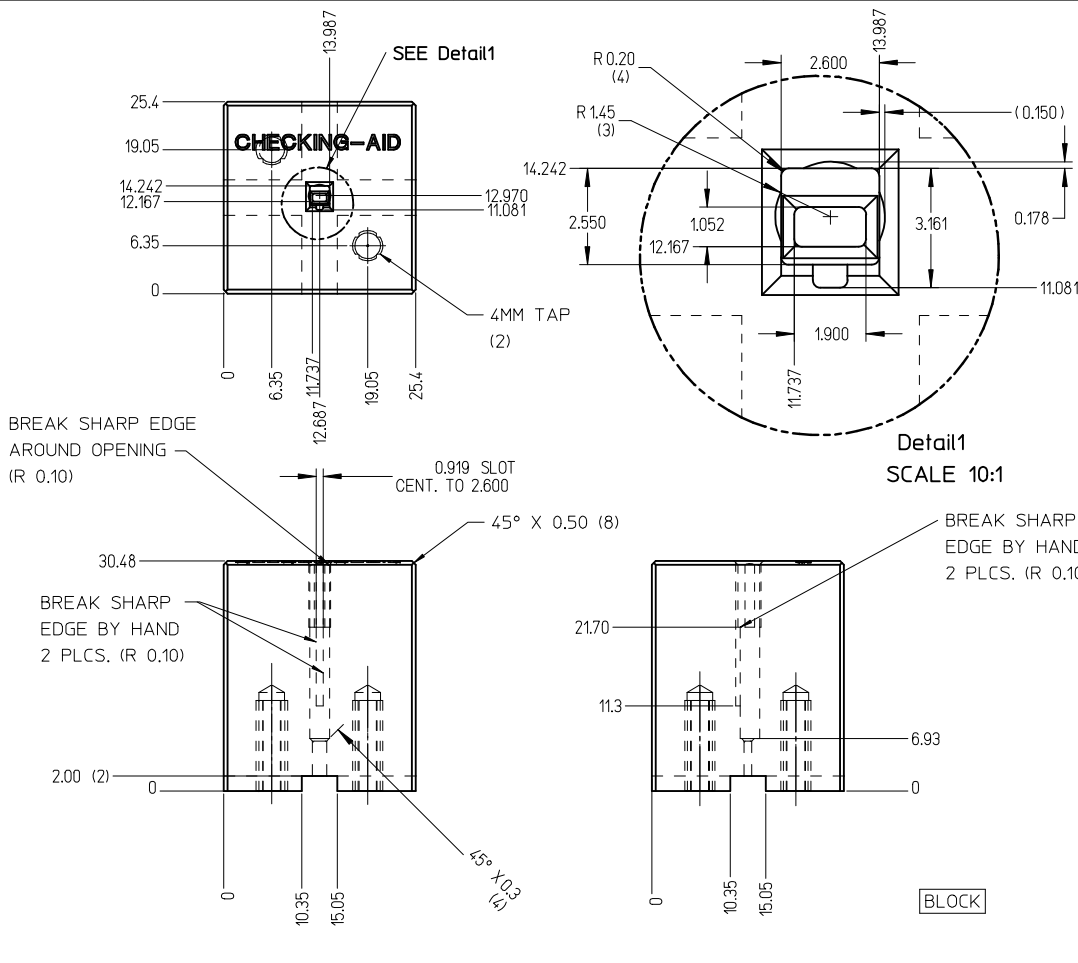

CHECKING-AID  
 2 PIECE ASM. A2 TOOL STEEL  
 HARDEN & GRIND TO A ROCKWELL  
 HARDNESS "C" SCALE OF 56-58

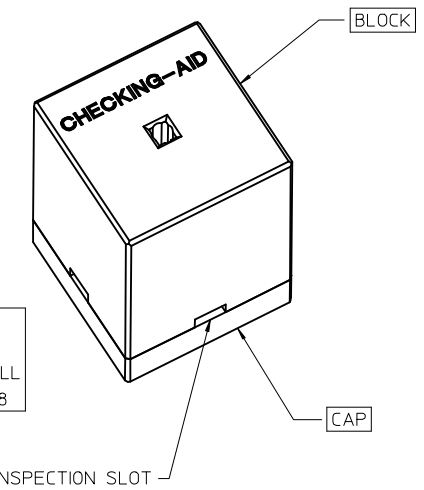

CHECKING AID TOLERANCE	
.XXX	= .005
.XX	= .03
.X	= .3

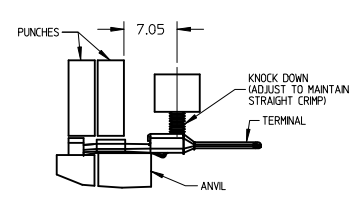
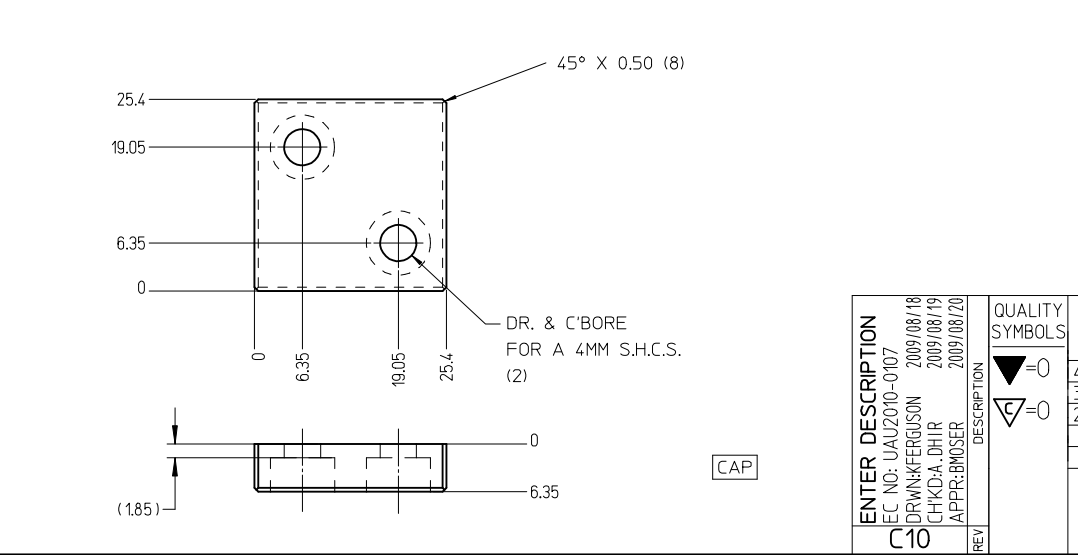

- CRIMP REQUIREMENTS:
1. CRIMP STRAIGHTNESS MUST BE MAINTAINED. USE A KNOCKDOWN TOOL LOCATED AS SHOWN. TERMINAL BOX MUST NOT BE DEFORMED
  2. AFTER CRIMPING, THE TERMINAL AND WIRE MUST FIT FREELY INTO THE CHECKING AID 33000-700. PROPER INSERTION DEPTH IS MET WHEN BLADE TIP STOPS ON CAP. SLOTS PROVIDED TO VISUALLY INSPECT STOPPAGE OF PIN TIP.
  3. FOR OTHER MECHANICAL REQUIREMENTS ON CRIMPED TERMINALS, REFER TO SAE/USCAR-21 (5-13-02) SECTIONS 4.2 (VISUAL INSPECTION), 4.3 (CROSS SECTION ANALYSIS) AND 4.4 (CONDUCTOR CRIMP PULLOUT FORCE)

<b>ENTER DESCRIPTION</b> EC NO: UAU2010-0107 DRWNG:FERGUSON 2009/08/18 CHKD:A.DHIR 2009/08/19 APPR:BMOSER 2009/08/20 REV:	<b>QUALITY SYMBOLS</b> ▽=0 ▽=0	<b>GENERAL TOLERANCES (UNLESS SPECIFIED)</b> <table border="1"> <thead> <tr> <th></th> <th>mm</th> <th>INCH</th> </tr> </thead> <tbody> <tr> <td>4 PLACES</td> <td>± .005</td> <td>± .0002</td> </tr> <tr> <td>3 PLACES</td> <td>± .002</td> <td>± .0001</td> </tr> <tr> <td>2 PLACES</td> <td>± 0.1</td> <td>± .004</td> </tr> <tr> <td>1 PLACE</td> <td>± 0.3</td> <td>± .012</td> </tr> </tbody> </table>		mm	INCH	4 PLACES	± .005	± .0002	3 PLACES	± .002	± .0001	2 PLACES	± 0.1	± .004	1 PLACE	± 0.3	± .012	<b>DIMENSION STYLE</b> <b>MM ONLY</b>	<b>SCALE</b> <b>2:1</b>	<b>DESIGN UNITS</b> <b>METRIC</b>	<b>THIRD ANGLE PROJECTION</b>
		mm	INCH																		
	4 PLACES	± .005	± .0002																		
	3 PLACES	± .002	± .0001																		
2 PLACES	± 0.1	± .004																			
1 PLACE	± 0.3	± .012																			
<b>CRIMP TOOLING SCALE 2:1</b>		<b>CRIMP REQUIREMENTS:</b>		<b>MX150 15MM BLADE TERMINAL</b>																	
<b>APPROVED BY</b> B.MOSER 2006/02/02		<b>DRAWN BY</b> L.PULLIAM 2006/01/31		<b>MOLEX INCORPORATED</b>																	
<b>ANGULAR ± 3°</b>		<b>MATERIAL NO.</b> <b>SEE TABLE</b>		<b>DOCUMENT NO.</b> SD-33000-001		<b>SHEET NO.</b> 4 OF 5															

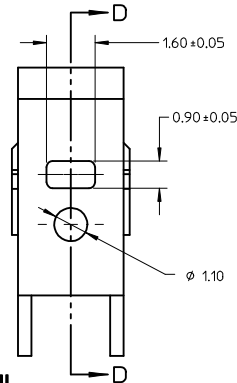
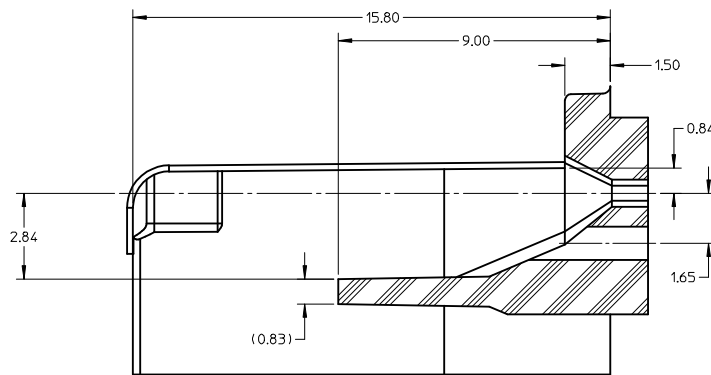
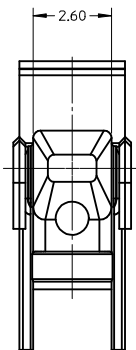

SECTION D-D TPA/INSERT DETAIL

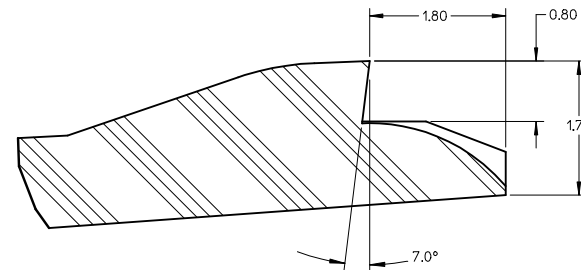
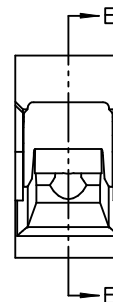
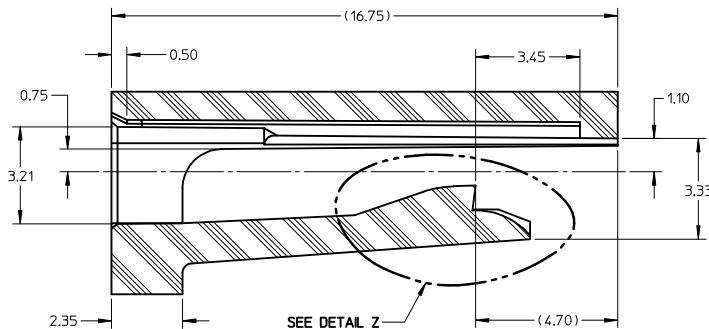
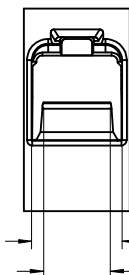

SECTION E-E HOUSING DETAIL

DETAIL Z SCALE 20:1

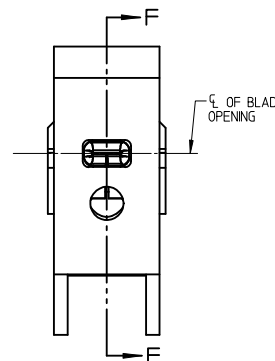
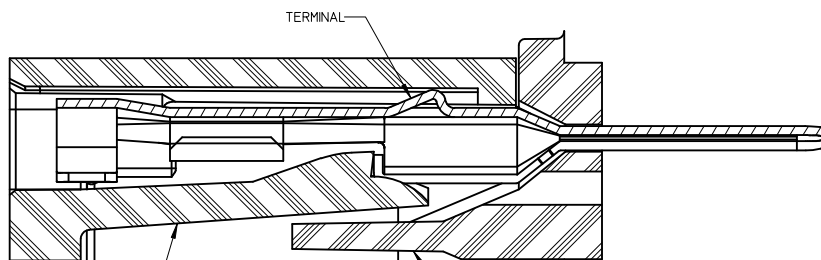
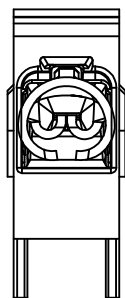

SECTION F-F BLADE CAVITY ASSEMBLY VIEWS

NOTES: (UNLESS OTHERWISE SPECIFIED)

1. TOLERANCES: LINEAR  $\pm 0.10$   
ANGULAR  $3^\circ$
2. ALL DRAFT WITHIN TOLERANCE
3. MAX RADII ON ALL CORNERS SHOWN SHARP: 0.10
4. MAX FLASH PERMISSIBLE: 0.1
5. EJECTOR PIN MARKS PERMISSIBLE IF FLUSH TO 0.25 BELOW SURFACE
6. MATERIAL: HOUSING/FINGER SPECIFICATION ENGINEERED FOR MATERIAL WITH THE FOLLOWING PROPERTIES:  
A. FLEXURAL MODULUS = 4,500 TO 9,400 MPa  
PER ASTM TEST D790  
B. ELONGATION AT YIELD = 2.3% OR BETTER  
PER ASTM TEST D638 TYPE V
7. CAVITY SPEC FOR USE ONLY WITH MOLEX BLADE TERMINAL PART NUMBERS (EXCEPT P/N'S FOR UNSEALED APPLICATIONS) SPECIFIED ELSEWHERE ON THIS DRAWING

BLADE CAVITY ASSEMBLY VIEWS

<b>ENTER DESCRIPTION</b> EC NO: UAU2010-0107 DRAWN BY: DRWINKFERGUSON 2009/08/18 CHECKED BY: CHKDA.DHIR 2009/08/19 APPR: BMOSEY 2009/08/20 REV: C10	<b>QUALITY SYMBOLS</b> $\nabla=0$ $\nabla=0$	<b>GENERAL TOLERANCES (UNLESS SPECIFIED)</b> <table border="1"> <tr> <th></th> <th>mm</th> <th>INCH</th> </tr> <tr> <td>4 PLACES</td> <td><math>\pm 0.10</math></td> <td><math>\pm 0.004</math></td> </tr> <tr> <td>3 PLACES</td> <td><math>\pm 0.15</math></td> <td><math>\pm 0.006</math></td> </tr> <tr> <td>2 PLACES</td> <td><math>\pm 0.25</math></td> <td><math>\pm 0.010</math></td> </tr> <tr> <td>1 PLACE</td> <td><math>\pm 0.38</math></td> <td><math>\pm 0.015</math></td> </tr> </table>		mm	INCH	4 PLACES	$\pm 0.10$	$\pm 0.004$	3 PLACES	$\pm 0.15$	$\pm 0.006$	2 PLACES	$\pm 0.25$	$\pm 0.010$	1 PLACE	$\pm 0.38$	$\pm 0.015$	<b>DIMENSION STYLE</b> MM ONLY	SCALE 8:1	DESIGN UNITS METRIC	THIRD ANGLE PROJECTION
		mm	INCH																		
	4 PLACES	$\pm 0.10$	$\pm 0.004$																		
	3 PLACES	$\pm 0.15$	$\pm 0.006$																		
2 PLACES	$\pm 0.25$	$\pm 0.010$																			
1 PLACE	$\pm 0.38$	$\pm 0.015$																			
DRAWN BY: L.PULLIAM 2006/01/31 CHECKED BY: A.DHIR 2006/02/01 APPROVED BY: B.MOSER 2006/02/02		TITLE MX150 15MM BLADE TERMINAL		MOLEX INCORPORATED																	
MATERIAL NO. SEE TABLE		DOCUMENT NO. SD-33000-001		SHEET NO. 5 OF 5																	
THIS DRAWING CONTAINS INFORMATION THAT IS PROPRIETARY TO MOLEX INCORPORATED AND SHOULD NOT BE USED WITHOUT WRITTEN PERMISSION																					