



Solid State Devices, Inc.

14701 Firestone Blvd * La Mirada, Ca 90638
 Phone: (562) 404-4474 * Fax: (562) 404-1773
 ssdi@ssdi-power.com * www.ssdi-power.com

Designer's Data Sheet

Part Number / Ordering Information ^{1/}

SGB ___ **UF** **SMS** ___
 L Screening^{2/} = None
 TX = TX Level
 TXV = TXV Level
 S = S Level
 L Package
 SMS = Surface Mount Square Tab
 L Recovery Time
 UF = Ultra Fast
 L Voltage
 10 = 1000 V
 15 = 1500 V
 20 = 2000 V
 25 = 2500 V
 30 = 3000 V
 35 = 3500 V

**SGB10UFSMS
 thru
 SGB35UFSMS**

**60 mAMP
 1000-3500 VOLTS
 60 nsec
 HIGH VOLTAGE
 RECTIFIER**

- FEATURES:**
- Ultra Fast Recovery: 60 nsec Maximum
 - PIV to 3500 Volts
 - Hermetically Sealed
 - Void-Free Construction
 - Metallurgically Bonded
 - 175°C Maximum Operating Temperature
 - Micro Miniature Package
 - TX, TXV, and Space Level Screening Available^{2/}

ELECTRICAL CHARACTERISTICS

Part Number	Peak Inverse Voltage	Average Rectified Current		Maximum Reverse Current		Maximum Forward Voltage	Maximum Surge Current (1 Cycle)	Maximum Reverse Recovery Time	Maximum Junction Capacitance	Typical Thermal Impedance
		mA		µA						
Symbol	PIV	I ₀		IR@PIV		V _F ^{4/}	I _{FSM}	t _{RR} ^{7/}	C _J	θ _{JE}
Units	Volts	mA		µA		Volts	Amps	nsec	pF	°C/W
Conditions		25°C	100°C	25°C	100°C	25°C	25°C	25°C	VR = 100V f _T = 1MHZ	
SGB10UFSMS	1000	60	50	0.1	10	9.5	5	60	1.0	165
SGB15UFSMS	1500	60	50	0.1	10	9.5	5	60	1.0	165
SGB20UFSMS	2000	60	50	0.1	10	9.5	5	60	1.0	165
SGB25UFSMS	2500	60	50	0.1	10	9.5	5	60	1.0	165
SGB30UFSMS	3000	60	50	0.1	10	9.5	5	60	1.0	165
SGB35UFSMS	3500	60	50	0.1	10	9.5	5	60	1.0	165

^{1/} For Ordering Information, Price, and Availability – Contact Factory.
^{2/} Screening based on MIL-PRF-19500. Screening flows available on request.
^{3/} Operating and testing over 10,000 V/inch may require encapsulation or immersion in a suitable dielectric material.
^{4/} I_F = I₀; Max. forward voltage measured with instantaneous forward pulse of 300µsec minimum.
^{5/} Max. lead temperature for soldering is 250°C, 3/8" from case for 5 sec maximum.
^{6/} Operating and storage temperature: -65°C to +175°C.
^{7/} Reverse Recovery Test Conditions: IF=50mA, IR=100mA, IRR=25mA, TA=25°C.
^{8/} Consult manufacturing for operating curves.

Surface Mount Square Tab

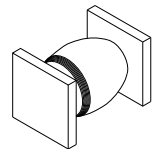



Solid State Devices, Inc.

14701 Firestone Blvd * La Mirada, Ca 90638
Phone: (562) 404-4474 * Fax: (562) 404-1773
ssdi@ssdi-power.com * www.ssdi-power.com

**SGB10UFSMS
thru
SGB35UFSMS**

PACKAGE OUTLINE: Surface Mount Square Tab

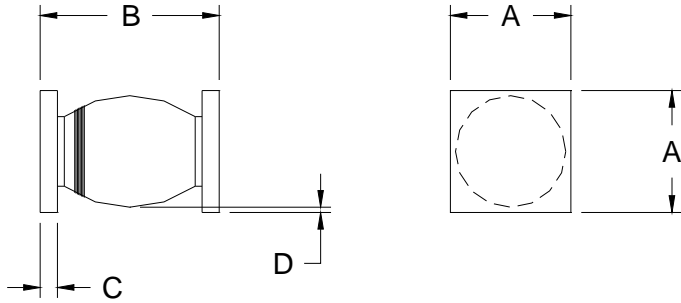

Dimensions are prior to soldering.

DIMENSIONS		
DIM	MIN	MAX
A	0.090"	0.100"
B	0.150"	0.210"
C	0.022"	0.028"
D	0.002"	—

NOTE: All specifications are subject to change without notification.
SCD's for these devices should be reviewed by SSDI prior to release.

DATA SHEET #: RV0005E

DOC