

M24758 - 26 B 03

Basic No. _____
Conduit Size Code (Table I) _____
Dash Number (Table II) _____

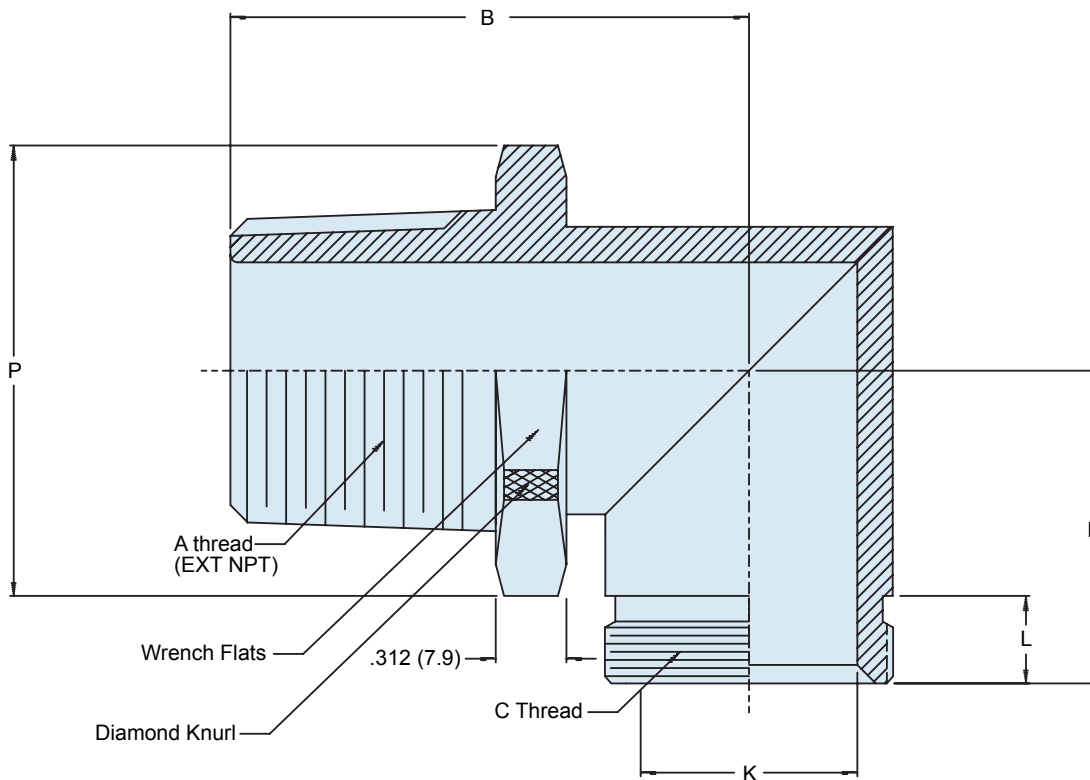

APPLICATION NOTES

1. Assembly identified with manufacturer's code identification number (Glenair, part number and classification code 490).
2. The M24758-27 adapter couples any fittings having a female tapered pipe thread to M24758-2, M24758-3 or M24758-4 fittings.
3. Material / Finish:
Elbow - 316 SST/Electroless nickel, matte finish.

MIL-PRF-24758-27
90° Adapter for Tapered Pipe Thread



MIL-PRF
24758A

TABLE I: CONDUIT SIZE CODE

CONDUIT SIZE CODE	C CLASS - 2A THREAD	D DIM	L +.03 (0.8) -.00	K DIA MIN	MAX ENTRY DASH NO.
B	.688-24 UNEF	.890 (22.6)	.25 (6.35)	.495 (12.57)	03

TABLE II: DASH NUMBER

DASH NO	A EXTERNAL TAPER PIPE THREAD	B DIM	P MAX DIA
03	.500-14 NPT	1.570 (39.9)	1.250 (31.8)