



**SINGLE-PHASE BRIDGE RECTIFIER
W005M THRU W10M**

VOLTAGE RANGE 50 to 1000 Volts
CURRENT 1.5 Amperes

FEATURES

- l Low cost
- l This series is UL recognized under component index, file number E127707
- l High forward surge current capability
- l Ideal for printed circuit board
- l High temperature soldering guaranteed: 260°C/10 second, 0.375”(9.5mm) lead length at 5 lbs. (2.3kg) tension.

MECHANICAL DATA

- l Case: Molded plastic body
- l Terminal: Lead solderable per MIL-STD-202E method 208C.
- l Polarity: Polarity symbols molded on case
- l Mounting position: Any
- l Weight: 0.042ounce, 1.2grams

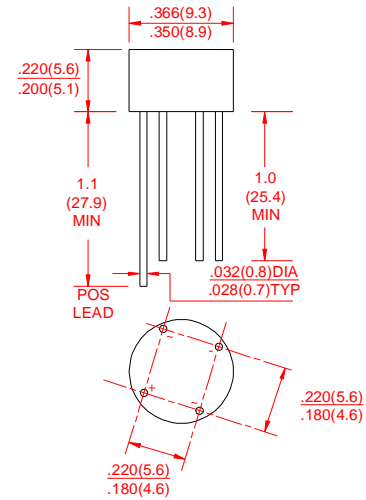

Dimensions in inches and (millimeters)

MAXIMUM RATINGS AND ELECTRICAL CHARACTERISTICS

Ratings at 25°C ambient temperature unless otherwise specified.
Single phase, half wave, 60Hz, resistive or inductive load.
For capacitive load derate current by 20%.

	SYMBOLS	W005M	W01M	W02M	W04M	W06M	W08M	W10M	UNITS	
Maximum Repetitive Peak Reverse Voltage	V_{RRM}	50	100	200	400	600	800	1000	Volts	
Maximum RMS Voltage	V_{RMS}	35	70	140	280	420	560	700	Volts	
Maximum DC Blocking Voltage	V_{DC}	50	100	200	400	600	800	1000	Volts	
Maximum Average Forward Rectified Output Current, at $T_A=25^\circ C$	$I_{(AV)}$	1.5							Amps	
Peak Forward Surge Current 8.3ms single half sine-wave superimposed on rated load (JEDEC Method)	I_{FSM}	50							Amps	
Maximum Instantaneous Forward Voltage at 1.0A	V_F	1.0							Volts	
Maximum DC Reverse Current at rated DC blocking voltage	$T_A=25^\circ C$	I_R	10							μ Amps
	$T_A=100^\circ C$		0.5							mAmps
Typical Junction Capacitance(Note1)	C_j	15							pF	
Typical Thermal Resistance(Note2)	$R_{\theta JA}$	40							$^\circ C/W$	
Operating Temperature Range	T_J	-55 to +125							$^\circ C$	
Storage Temperature Range	T_{STG}	-55 to +150							$^\circ C$	

NOTES:

1. Measured at 1.0MHz and applied reverse voltage of 4.0 volts.
2. Unit mounted on P.C. board with 0.22”×0.22”(5.5×5.5mm)copper pads,0.375”(9.5mm)lead length.



MASTER INSTRUMENT CORPORATION

SINGLE-PHASE BRIDGE RECTIFIER
W005M THRU W10M

VOLTAGE RANGE 50 to 1000 Volts
CURRENT 1.5 Amperes

RATINGS AND CHARACTERISTIC CURVES W005M THRU W10M

FIG.1- DERATING CURVE FOR
OUTPUT RECTIFIED CURRENT

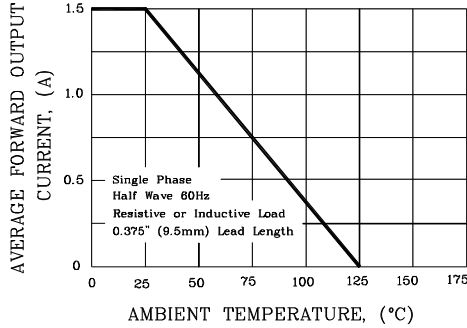

FIG.2- MAXIMUM NON-REPETITIVE PEAK
FORWARD SURGE CURRENT PER ELEMENT

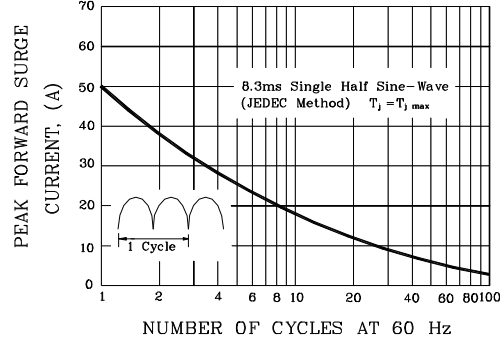

FIG.3- TYPICAL FORWARD CHARACTERISTICS
PER BRIDGE ELEMENT

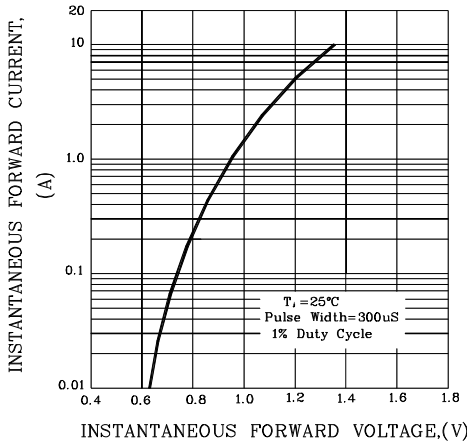

FIG.4- TYPICAL REVERSE CHARACTERISTICS
PER BRIDGE ELEMENT

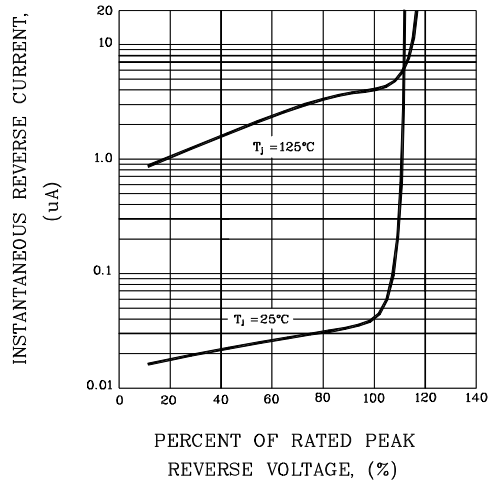

FIG.5- TYPICAL JUNCTION CAPACITANCE
PER BRIDGE ELEMENT

