

规格书编号

SPEC NO :

产品规格书

SPECIFICATION

CUSTOMER 客户: _____

PRODUCT 产品: **SAW FILTER**

MODEL NO 型号: **HDBF07006D61**

PREPARED 编制: _____ CHECKED 审核: **Houshihong**

APPROVED 批准: **CHARLES** DATE 日期: **2007-01-25**

客户确认 CUSTOMER RECEIVED:		
审核 CHECKED	批准 APPROVED	日期 DATE

无锡市好达电子有限公司
Shoulder Electronics Limited

更改历史记录
History Record

更改日期 Date	规格书编号 Spec No	产品型号 Part No	客户产品型号 Customer No	更改内容描述 Modify Content	备注 Remark

1. SCOPE

This specification shall cover the characteristics of SAW filter HDBF07006D61

2. ELECTRICAL SPECIFICATION

DC Voltage VDC	10V
AC Voltage Vpp	10V50Hz/60Hz
Operation temperature	-20°C to +55°C
Storage temperature	-45°C to +85°C
RF Power Dissipation	0dBm

Electronic Characteristics

This filter can be used in single-end Input/Output or Balanced.

Item	Spec requirement			Unit
	Min.	Typ.	Max.	
IF center Frequency f_0	-	70	-	MHz
Minimum insertion loss attenuation		23	25	dB
1dB Bandwidth	-	6.5	-	MHz
3dB Bandwidth	-	6.8	-	MHz
40dB Bandwidth	-	8.1	-	MHz
Amplitude ripple(p-p) $\Delta\alpha$ $f_0 \pm 3.125\text{MHz}$	-	0.6	1.0	dB
Group delay ripple $f_0 \pm 3.125\text{MHz}$	-	70	150	ns
Operating Temperature(°C)	-40		+85	°C
Storage Temperature(°C)	-55		+125	°C
Package	DIP 20x12			mm
f_0 frequency shift for all temperature relative to T0 (25°C)			25	kHz

3. DIMENSION

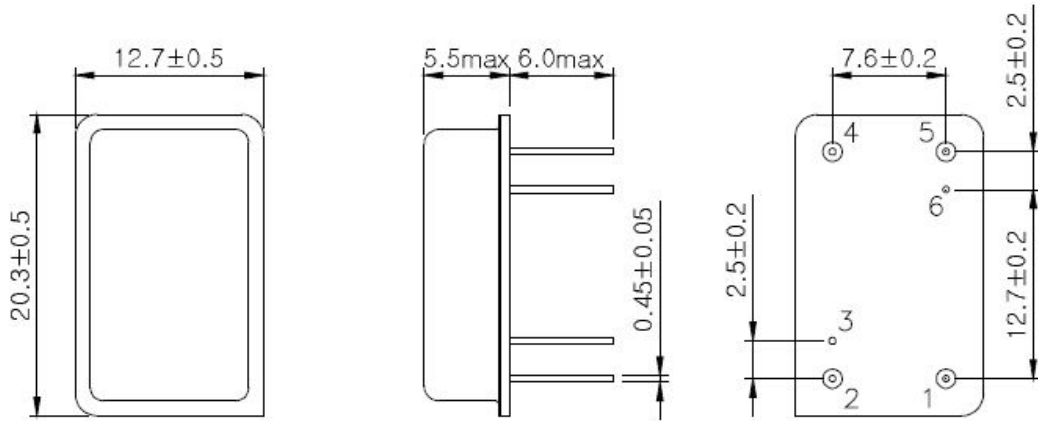

Pin Configuration	
1	Input
4	Output
2, 5	Ground
Other	Case ground

4. TEST CIRCUIT

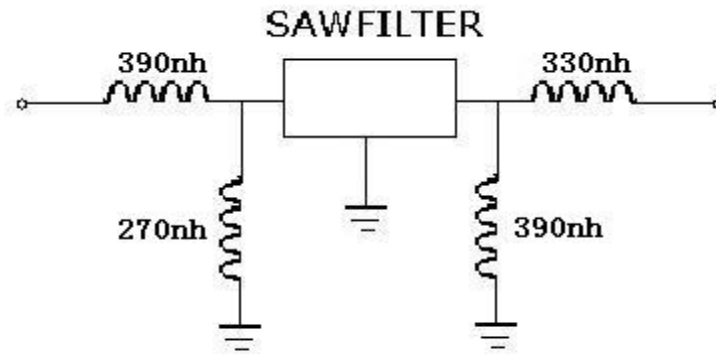

5. ENVIRONMENTAL CHARACTERISTICS

5-1 High temperature exposure

Subject the device to +85°C for 16 hours. Then release the filter into the room conditions for 24 hours prior to the measurement. It shall fulfill the specifications in table 1.

5-2 Low temperature exposure

Subject the device to -20°C for 16 hours. Then release the device into the room conditions for 24 hours prior to the measurement. It shall fulfill the specifications in table 1.

5-3 Temperature cycling

Subject the device to a low temperature of -40°C for 30 minutes. Following by a high temperature of +80°C for 30 Minutes. Then release the device into the room conditions for 24 hours prior to the measurement. It shall meet the specifications in table 1.

5-4 Resistance to solder heat

Dip the device terminals no closer than 1.5mm into the solder bath at 260°C \pm 10°C for 10 \pm 1 sec. Then release the device into the room conditions for 4 hours. The device shall meet the specifications in table 1.

5-5 Solderability

Subject the device terminals into the solder bath at 245°C \pm 5°C for 5s, More than 95% area of the terminals must be covered with new solder. It shall meet the specifications in table 1.

5-6 Mechanical shock

Drop the device randomly onto the concrete floor from the height of 1m 3 times. the device shall fulfill the specifications in table 1.

5-7 Vibration

Subject the device to the vibration for 1 hour each in x,y and z axes with the amplitude of 1.5 mm at 10 to 55 Hz. The device shall fulfill the specifications in table 1.

5-8 Lead fatigue

5-8-1 Pulling test

Weight along with the direction of lead without an shock 1kg. The device shall satisfy all the initial Characteristics.

5-8-2 Bending test

Lead shall be subject to withstand against 90°C bending with 450g weight in the direction of thickness. This operation shall be done toward both direction. The device shall show no evidence of damage and shall satisfy all the initial electrical characteristics.

Typical frequency response

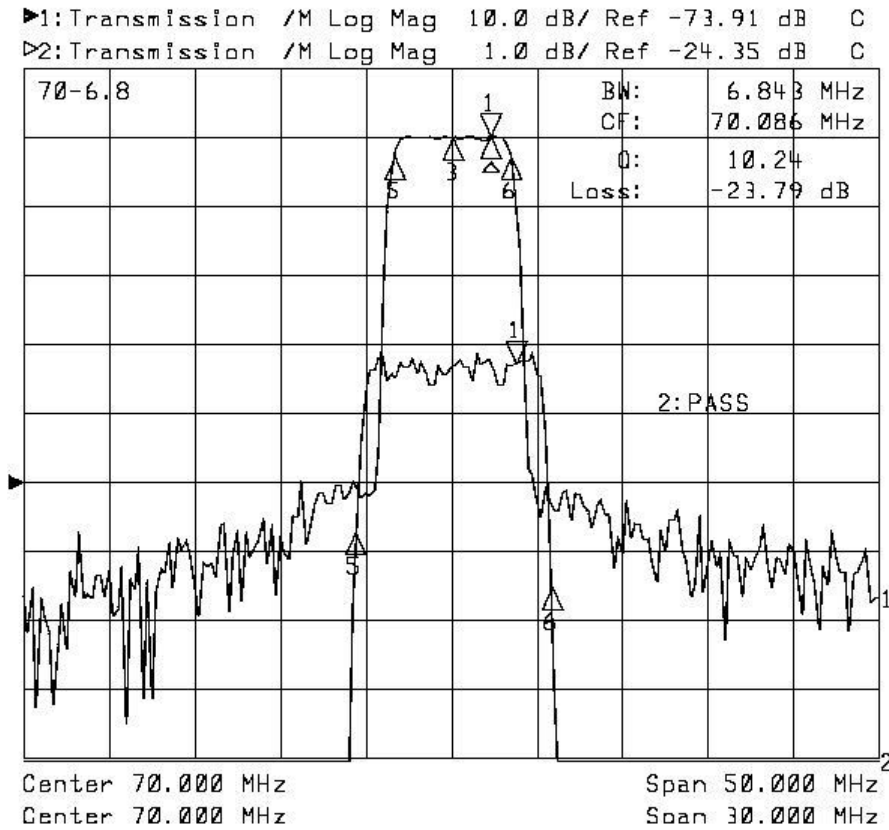

6. REMARK

6.1 Static voltage

Static voltage between signal load & ground may cause deterioration & destruction of the component. Please avoid static voltage.

6.2 Ultrasonic cleaning

Ultrasonic vibration may cause deterioration & destruction of the component. Please avoid ultrasonic cleaning

6.3 Soldering

Only leads of component may be soldered. Please avoid soldering another part of component.