

PLEASE CHECK WWW.MOLEX.COM FOR LATEST PART INFORMATION

Part Number: **0002082004**
Status: **Active**
Overview: [mlx](#)
Description: MLX Crimp Terminal 42023, 14-20 AWG, Bag Tin (Sn)

Documents:

[Drawing \(PDF\)](#) [RoHS Certificate of Compliance \(PDF\)](#)
[Product Specification PS-42022-0001 \(PDF\)](#)

General

Product Family	Crimp Terminals
Series	42023
Crimp Quality Equipment	Yes
MolexKits	Yes
Overview	mlx
Product Name	MLX™

Physical

Gender	Male
Material - Metal	Brass
Material - Plating Mating	Tin
Material - Plating Termination	Tin
Packaging Type	Bag
Plating min: Mating (µin)	20
Plating min: Mating (µm)	0.50
Plating min: Termination (µin)	20
Plating min: Termination (µm)	0.50
Termination Interface: Style	Crimp or Compression
Wire Insulation Diameter	1.52-3.30mm (.060-.130")
Wire Size AWG	14, 16, 18, 20
Wire Size mm²	N/A

Material Info

Old Part Number 42023-2A1L

Reference - Drawing Numbers

Product Specification	PS-42022-0001
Sales Drawing	SD-42023-****

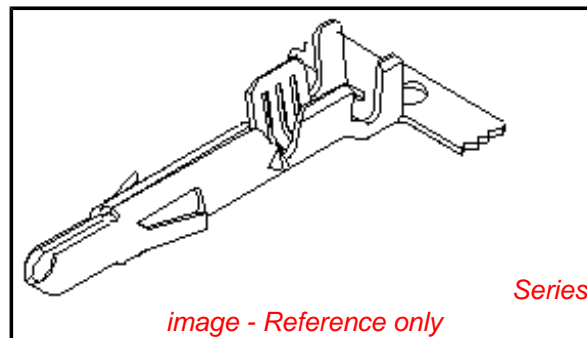

EU RoHS

**ELV and RoHS
Compliant**
REACH SVHC
Contains SVHC: No
**Halogen-Free
Status**

China RoHS



Halogen-Free
**Need more information on product
environmental compliance?**

Email productcompliance@molex.com
 For a multiple part number RoHS Certificate of Compliance, [click here](#)

Please visit the [Contact Us](#) section for any non-product compliance questions.

Search Parts in this Series

[42023Series](#)

Application Tooling | [FAQ](#)

Tooling specifications and manuals are found by selecting the products below. Crimp Height Specifications are then contained in the Application Tooling Specification document.

Global

Description	Product #
Extraction Tool	0011010168
HAND CRIMP TOOL	0638116800

PLEASE CHECK WWW.MOLEX.COM FOR LATEST PART INFORMATION

SOLID PIN TERMINAL
42023-1***

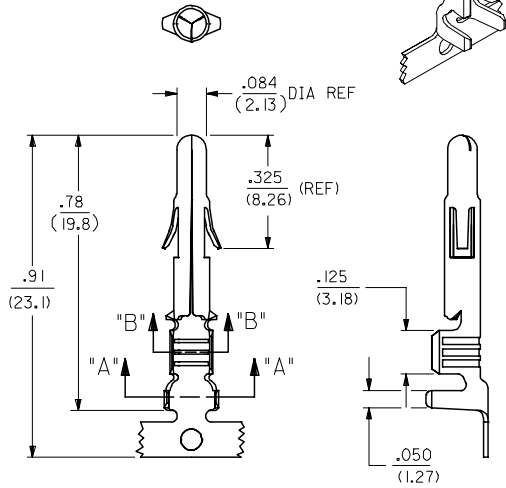

SPLIT PIN TERMINAL
42023-2***

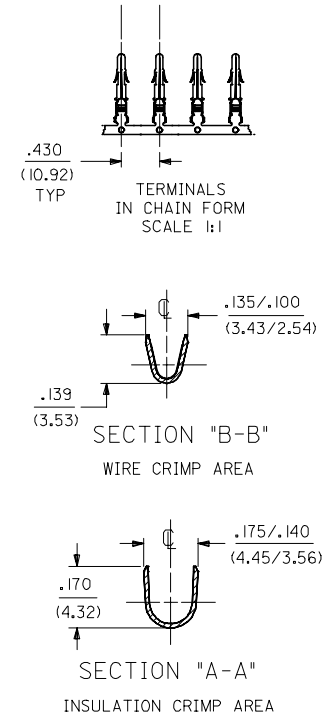
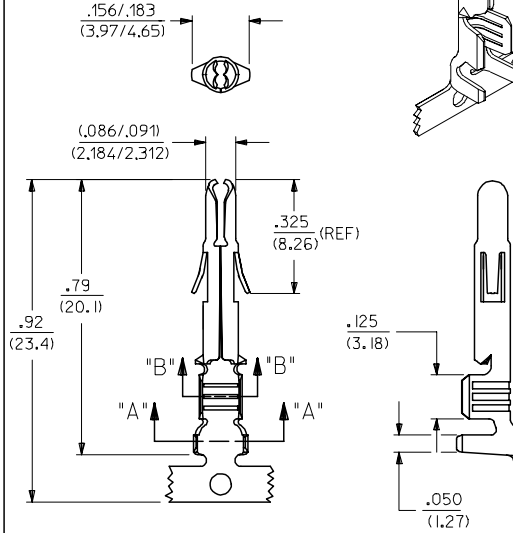

SEE SHEET2 FOR CHART, MATERIAL, PLATING, NOTES, AND CRIMP OPTIONS

EC NO: 12005-0302 DRWN: SUDHIR 2004/09/27 CHKD: KPRASAD 2004/09/27 APPR: KPRASAD 2004/09/27	QUALITY SYMBOLS ▽=0 ▽=0	GENERAL TOLERANCES (UNLESS SPECIFIED)		DIMENSION STYLE IN/MM	SCALE 4:1	DESIGN UNITS INCH	THIRD ANGLE PROJECTION	
		4 PLACES ± --- ± ---	mm INCH	DRAWN BY SUDHIR	DATE 2004/09/24	TITLE TERMINAL, PIN .084/(2.13) DIA. SERIES		
		3 PLACES ± --- ± .010		CHECKED BY KPRASAD	DATE 2004/09/24	MOLEX INCORPORATED		
		2 PLACES ± 0.25 ± .015 1 PLACE ± 0.38 ± --- ANGULAR ± 1/2°		APPROVED BY KPRASAD	DATE 2004/09/24	MATERIAL NO. SEE CHART	DOCUMENT NO. SD-42023-****	SHEET NO. 1 OF 2
DRAFT WHERE APPLICABLE MUST REMAIN WITHIN DIMENSIONS		SIZE A2		THIS DRAWING CONTAINS INFORMATION THAT IS PROPRIETARY TO MOLEX INCORPORATED AND SHOULD NOT BE USED WITHOUT WRITTEN PERMISSION				

ENG. NO.	EDP NO.	FINISH (REF)	CONTACT AREA (REF)	CRIMP AREA (REF)	MATERIAL (REF)	TERMINAL TYPE	WIRE SIZE	INSULATION DIAMETER
X-42023-1A1	PRELIMINARY	SDES-88-P901	----	----	C26000	SOLID	#14-#20 AWG	.060-.130
X-42023-1AIL	PRELIMINARY	SDES-88-P901	----	----	C26000	SOLID	#14-#20 AWG	.060-.130
42023-2A1	002-08-2003	SDES-88-P901	----	----	C26000	SPLIT	#14-#20 AWG	.060-.130
42023-2AIL	002-08-2004	SDES-88-P901	----	----	C26000	SPLIT	#14-#20 AWG	.060-.130
42023-2B1	002-08-2005	SDES-88-P901	----	----	C51000	SPLIT	#14-#20 AWG	.060-.130
42023-2B1L	002-08-2006	SDES-88-P901	----	----	C51000	SPLIT	#14-#20 AWG	.060-.130
42023-2A2	002-08-2007	SEE NOTE 5	.000030 MIN GOLD	.000100 MIN MATTE TIN	C26000	SPLIT	#14-#20 AWG	.060-.130
42023-2A2L	002-08-2008	SEE NOTE 5	.000030 MIN GOLD	.000100 MIN MATTE TIN	C26000	SPLIT	#14-#20 AWG	.060-.130
42023-2B2	002-08-2009	SEE NOTE 5	.000030 MIN GOLD	.000100 MIN MATTE TIN	C51000	SPLIT	#14-#20 AWG	.060-.130
42023-2B2L	002-08-2010	SEE NOTE 5	.000030 MIN GOLD	.000100 MIN MATTE TIN	C51000	SPLIT	#14-#20 AWG	.060-.130

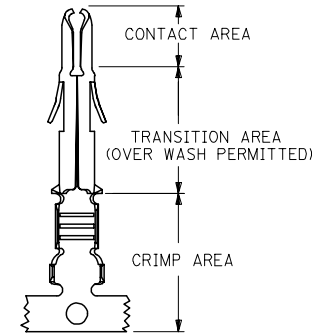

PLATING REGIONS

APPLIES TO GOLD PLATED TERMINALS ONLY

NOTES:

1) PIN TERMINALS FOR USE WITH THE .084/(2.13) SERIES HOUSINGS:

- PLUG (42021-**) CAP (42022-**)

2) PIN TERMINALS MATE WITH SOCKET TERMINALS: .084/(2.13) DIA. SERIES (42024-****).

3) TERMINALS FINISHED IN CHAIN UNLESS SPECIFIED LOOSE. "L" SUFFIX INDICATES LOOSE FORM. (SEE TABLE)

4) MATERIAL: .012/(0.30) THICK STRIP:
 A = BRASS, *C26000, PER SMES-124-C7.
 B = PHOSPHOR BRONZE, *C51000, PER SMES-124-E7.

5) FINISH:
 1 = HOT TIN DIP 20 m.l./(.51 MICRONS) MINIMUM (PER SDES-88-P901).
 2 = 30 M.I (0.75 MICRONS) MIN GOLD & 100 M.I (2.50 MICRONS) MIN SELECT TIN 50 M.I (1.25 MICRONS) MIN NICKEL OVERALL

6) CRIMP RANGE: SCC CIAR1.

7) PRODUCT SPECIFICATION PS-42022-0001 APPLIES.

LEGEND:

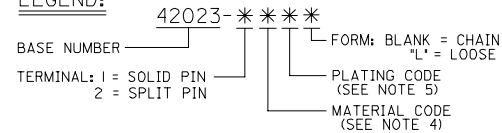

EC NO: 12005-0302 DRWN: SUDHIR 2004/09/27 CHKD: KPRASAD 2004/09/27 APPR: KPRASAD 2004/09/27	QUALITY SYMBOLS ▽=0 ▽=0	GENERAL TOLERANCES (UNLESS SPECIFIED)		DIMENSION STYLE IN/MM	SCALE ---	DESIGN UNITS INCH	THIRD ANGLE PROJECTION			
		4 PLACES ± --- ± ---	3 PLACES ± --- ± ---	2 PLACES ± --- ± ---	1 PLACE ± --- ± ---	ANGULAR ± --- °	DRAWN BY DATE SUDHIR 2004/09/27	CHECKED BY DATE KPRASAD 2004/09/27	APPROVED BY DATE KPRASAD 2004/09/27	TITLE TERMINAL, PIN .084/(2.13) DIA. SERIES
		DRAFT WHERE APPLICABLE MUST REMAIN WITHIN DIMENSIONS			SEE CHART	MATERIAL NO.	DOCUMENT NO. SD-42023-****	SHEET NO. 2 OF 2		
		THIS DRAWING CONTAINS INFORMATION THAT IS PROPRIETARY TO MOLEX INCORPORATED AND SHOULD NOT BE USED WITHOUT WRITTEN PERMISSION								