

T1P3003028-SP

30 W, 28V, 500 MHz—2GHz, Pulsed, Powerband™ pHEMT RF Power Transistor

Introduction

The T1P3003028-SP is a POWERBAND™ discrete pHEMT, depletion mode, RF Power transistor designed to operate from 500MHz to 2GHz in wide-band circuits. The device has an instantaneous band-width P1dB output power of 30watts across the entire band when operated in the TriQuint wide-band test fixture. The T1P3003028-SP can also be used in narrow band applications and is rated at 40Watts P1dB at 2GHz.

Figure 1. Available Packages



Features

- Pulse Characterization
- Exceptional Instantaneous band-width performance from 500MHz – 2GHz
- Increased efficiency results in significant advantages
 - Smaller and lighter systems
 - Reduced system component costs
 - Reduced energy consumption
- Typical Performance ratings
 - Wide-Band 500MHz-2GHz (as tested in TriQuint Wideband Fixture)
 - 10dB gain
 - 50% Efficiency
 - 30Watt P1dB

- Narrow Band up to 2GHz
 - 12dB gain
 - 58% efficiency
 - 40Watt P1dB

Table 1. Maximum Ratings

Sym	Parameter	Value	Notes
V ⁺	Positive Supply Voltage	28 V	2/
V ⁻	Negative Supply Voltage Range	-5V to 0V	
I ⁺	Positive Supply Current	5.6A	2/
I _G	Gate Supply Current	70 mA	
P _D	Power Dissipation	See note 3	2/ 3/
T _{CH}	Operating Channel Temperature	150° C	4/

- 1/ These ratings represent the maximum operable values for this device.
- 2/ Combinations of supply voltage, supply current, input power, and output power shall not exceed P_D.
- 3/ For a median life time of 1E+6 hrs, Power dissipation is limited to: P_D(max) = (150 °C – T_{BASE} °C) / 5.6 (°C/W)
- 4/ Junction operating temperature will directly affect the device median time to failure(T_M). For maximum life, it is recommended that junction temperatures be maintained at the lowest possible levels.

Table 2. Thermal Information

Parameter	Test Conditions	TCH (°C)	θJC (°C/W)	T _M (HRS)
θ _{JC} Thermal Resistance (channel to backside of carrier)	V _d = 10 V I _{dq} = 900 mA P _{diss} = 9 W	145	5.6	1.6E+6

Preliminary Data Sheet
Subject to Change

T1P3003028-SP

30 W, 28V, 500 MHz—2GHz, Pulsed, Powerband™ pHEMT RF Power Transistor

Electrical Characteristics

Recommended operating conditions apply unless otherwise specified: $T_A = 25\text{ }^\circ\text{C}$.

Table 3. dc Characteristics

Parameter	Symbol	Min	Typ	Max	Unit
Saturated Drain Current	I_{dss}	—	4000	—	mA
Transconductance	G_m	—	3300	—	mS
Pinch-off Voltage	V_p	-1.5	-1	-0.6	V
Breakdown Voltage Gate-Source	V_{BGS}	-40	—	-30	V
Breakdown Voltage Gate-Drain	V_{BGD}	-45	—	-35	V

Table 4. RF Characteristics

Parameter	Symbol	Min	Typ	Max	Unit
Functional Tests, Instantaneous Band-Width 100uS, 10% (Tested in TriQuint's Wide-Band Test Fixture)					
Gain @ P1dB, 500MHz-2GHz ($V_{DS} = 28\text{ V}$, $POUT = 30\text{ W}$, $IDD = 400\text{ mA}$)	G	—	10	—	dB
P1dB, 500MHz-2GHz ($V_{DS} = 28\text{ V}$, $POUT = 30\text{ W}$, $IDD = 400\text{ mA}$)	P1dB	—	30	—	W
Power Added Efficiency, 500MHz-2GHz ($V_{DS} = 28\text{ V}$, $POUT = 30\text{ W}$, $IDD = 400\text{ mA}$)	—	—	45	—	%
Functional Tests, Narrow Band RF Performance 100uS, 10% (2GHz)					
Gain ($V_{DS} = 28\text{ V}$, $POUT = 40\text{ W}$, $IDQ = 400\text{ mA}$)	G	—	12	—	dB
Output Power ($V_{DS} = 28\text{ V}$, 1 dB compression, $IDQ = 400\text{ mA}$)	P1dB	—	40	—	W
Drain Efficiency ($V_{DS} = 28\text{ V}$, $POUT = P1dB$, $IDQ = 400\text{ mA}$)	—	—	55	—	%
Ruggedness ($V_{DS} = 28\text{ V}$, $POUT = 40\text{ W}$, $IDQ = 400\text{ mA}$, $f = 500\text{ MHz}$, $V_{SWR} = 3:1$, all angles)	—	No degradation in output power.			

Preliminary Data Sheet
Subject to Change

T1P3003028-SP

30 W, 28V, 500 MHz—2GHz, Pulsed, Powerband™ pHEMT RF Power Transistor

Figure 2. P1dB & Efficiency (Narrow Band Performance Plotted over Frequency)

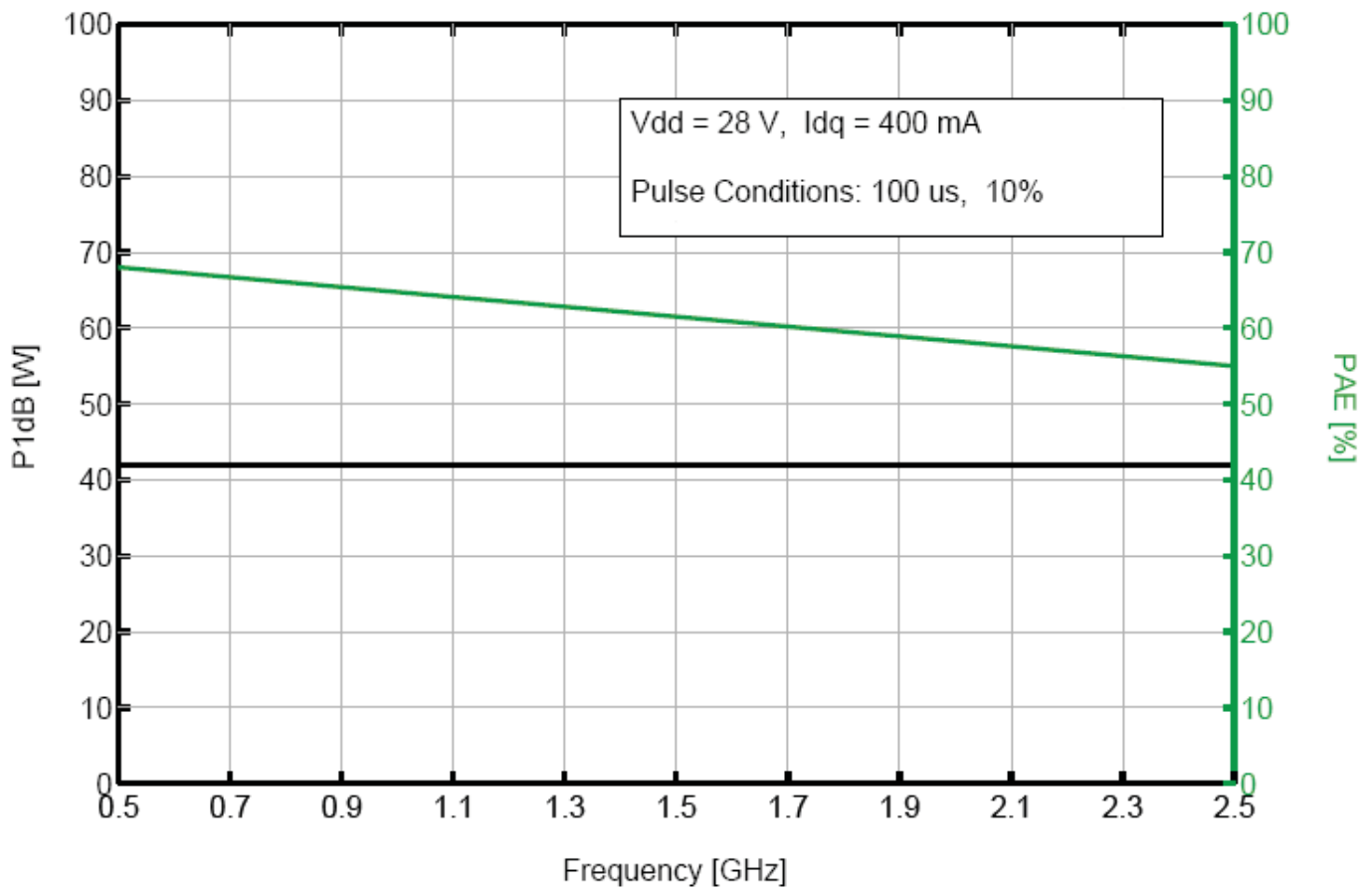

Preliminary Data Sheet
Subject to Change

T1P3003028-SP

30 W, 28V, 500 MHz—2GHz, Pulsed, Powerband™ pHEMT RF Power Transistor

Figure 3. P1dB & Gain (Narrow Band Performance Plotted over Frequency)

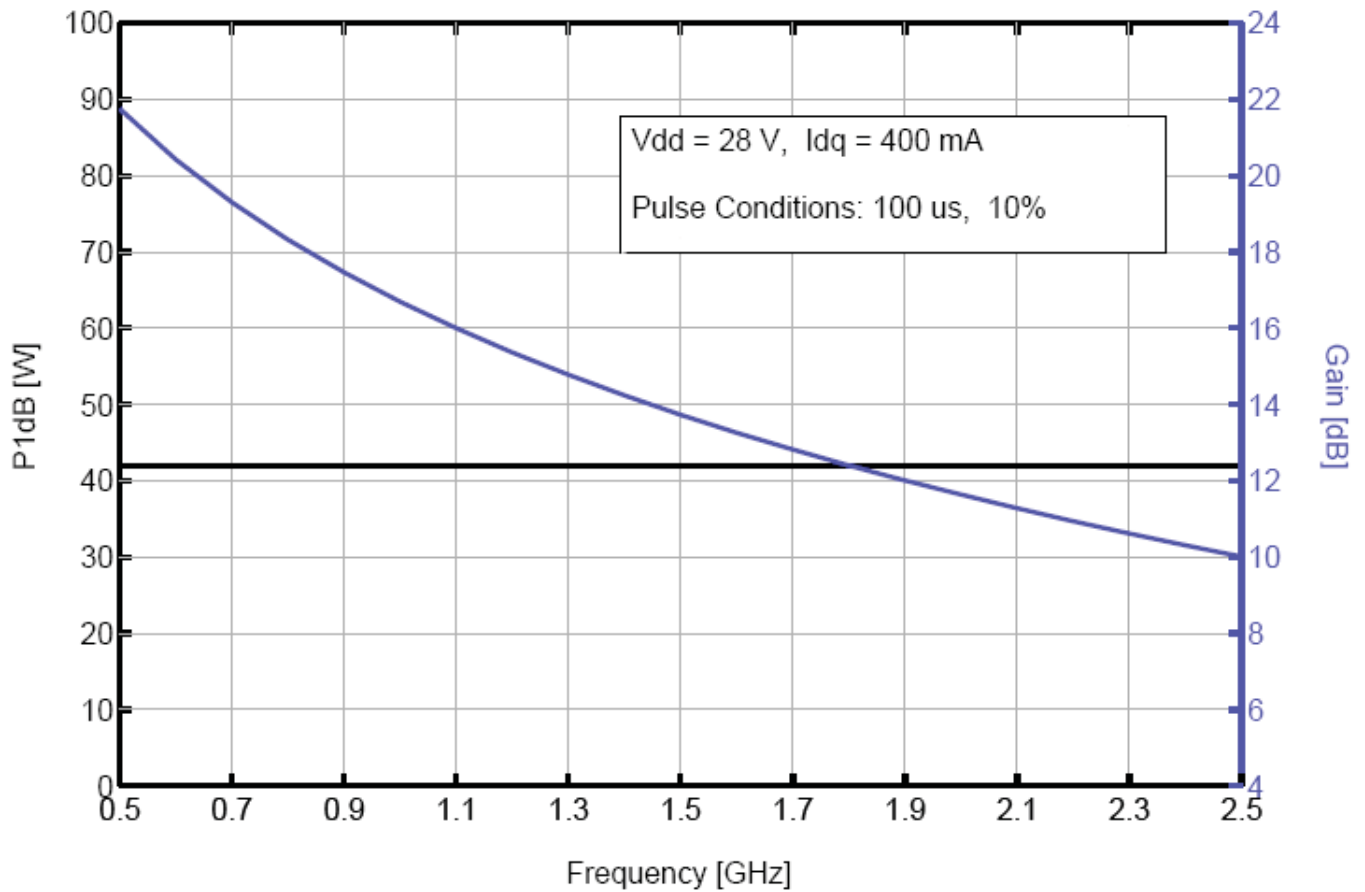

Preliminary Data Sheet
Subject to Change

T1P3003028-SP

30 W, 28V, 500 MHz—2GHz, Pulsed, Powerband™ pHEMT RF Power Transistor

Figure 4. Plot of impedances to be presented to the Source & Load of the device for optimal RF performance

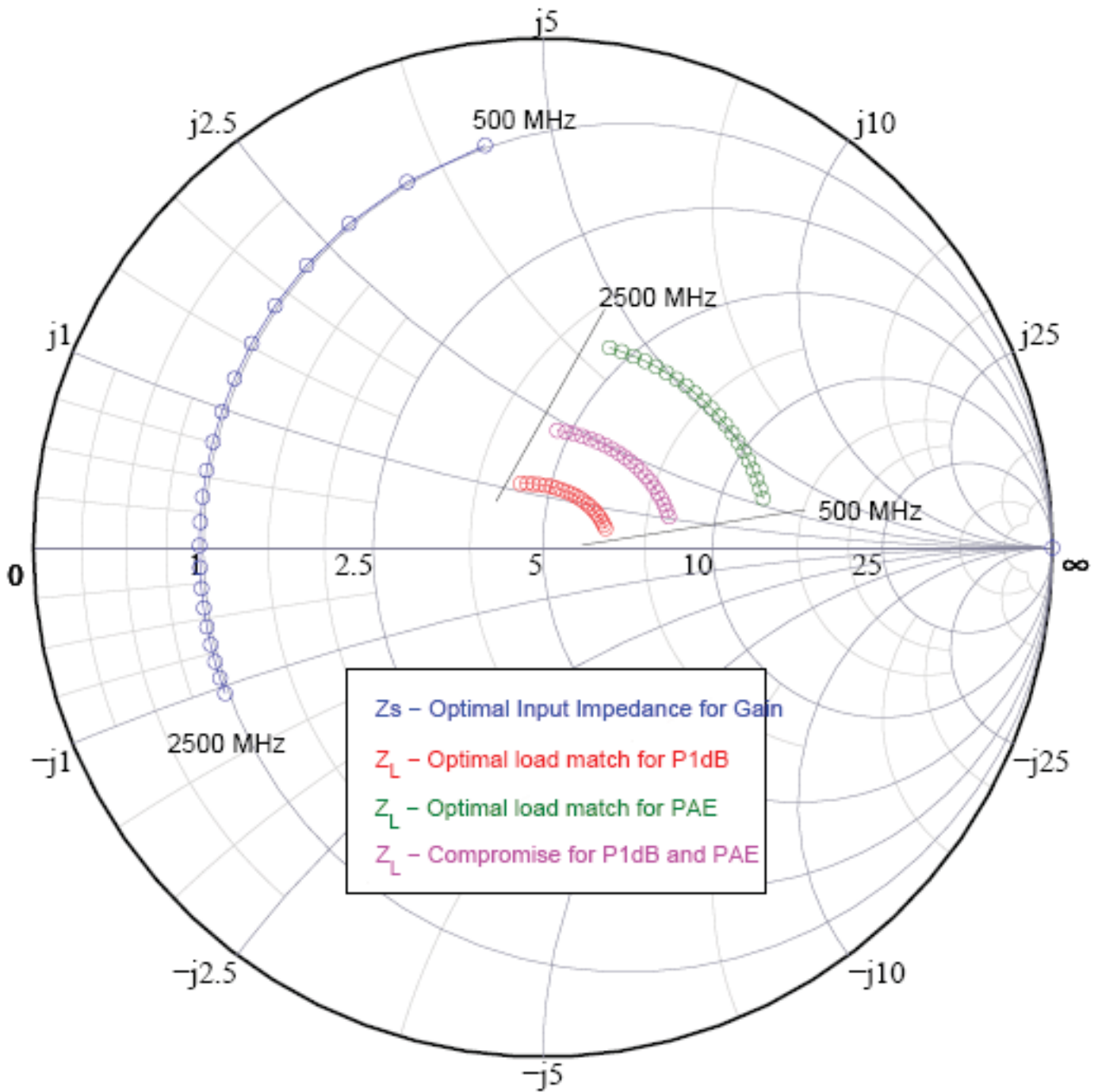

Preliminary Data Sheet
Subject to Change

T1P3003028-SP

30 W, 28V, 500 MHz—2GHz, Pulsed, Powerband™ pHEMT RF Power Transistor

Table 5. Table of RF performance that the device typically exhibits when placed in the specified impedance environment. The impedances are not the impedances of the device, they are the impedances presented to the device via an RF circuit or Load-pull system. The data is representative of typical device performance for both 100uSecond pulse width, 10% duty cycle conditions and 1000uSecond pulse width, 10% duty cycle conditions.

frequency	gamma-in (real)	gamma-in (imag)	Z-in (real)	Z-in (imag)	gamma-out (real)	gamma-out (imag)	Z-out (real)	Z-out (imag)	Gain	P1db [W]	P1db [dBm]	PAE [%]
500	-0.948	0.162	0.98	4.24	-0.713	0.033	8.37	1.14	21.75	42.0	46.2	68
600	-0.953	0.130	0.98	3.39	-0.716	0.040	8.26	1.34	20.42	42.0	46.2	67
700	-0.956	0.106	0.98	2.76	-0.719	0.045	8.12	1.53	19.30	42.0	46.2	67
800	-0.958	0.087	0.98	2.26	-0.723	0.051	7.98	1.71	18.32	42.0	46.2	66
900	-0.959	0.072	0.98	1.86	-0.728	0.056	7.81	1.87	17.46	42.0	46.2	65
1000	-0.960	0.059	0.98	1.53	-0.733	0.061	7.64	2.01	16.69	42.0	46.2	65
1100	-0.961	0.048	0.98	1.24	-0.738	0.065	7.46	2.14	16.00	42.0	46.2	64
1200	-0.961	0.038	0.98	0.98	-0.743	0.069	7.27	2.26	15.36	42.0	46.2	63
1300	-0.961	0.029	0.98	0.75	-0.749	0.072	7.08	2.35	14.78	42.0	46.2	63
1400	-0.962	0.021	0.98	0.55	-0.755	0.075	6.88	2.43	14.24	42.0	46.2	62
1500	-0.962	0.014	0.98	0.36	-0.761	0.078	6.68	2.50	13.73	42.0	46.2	62
1600	-0.962	0.007	0.98	0.18	-0.767	0.080	6.47	2.54	13.26	42.0	46.2	61
1700	-0.962	0.001	0.98	0.02	-0.774	0.081	6.27	2.58	12.82	42.0	46.2	60
1800	-0.962	-0.005	0.98	-0.14	-0.780	0.083	6.07	2.60	12.40	42.0	46.2	60
1900	-0.962	-0.011	0.98	-0.28	-0.786	0.083	5.87	2.60	12.01	42.0	46.2	59
2000	-0.962	-0.016	0.98	-0.42	-0.792	0.084	5.67	2.60	11.64	42.0	46.2	58
2100	-0.962	-0.022	0.98	-0.56	-0.799	0.084	5.48	2.58	11.28	42.0	46.2	58
2200	-0.961	-0.027	0.98	-0.69	-0.805	0.083	5.29	2.55	10.94	42.0	46.2	57
2300	-0.961	-0.031	0.98	-0.81	-0.811	0.083	5.10	2.52	10.62	42.0	46.2	56
2400	-0.961	-0.036	0.98	-0.93	-0.817	0.082	4.93	2.47	10.31	42.0	46.2	56
2500	-0.961	-0.041	0.98	-1.05	-0.823	0.080	4.75	2.42	10.01	42.0	46.2	55

Note: Data sheet will be updated with TriQuint wide-band test fixture characterization data in the near future.

Preliminary Data Sheet
Subject to Change

T1P3003028-SP

30 W, 28V, 500 MHz—2GHz, Pulsed, Powerband™ pHEMT RF Power Transistor

Package Dimensions

Note: All dimensions in inches. Scale 8:1

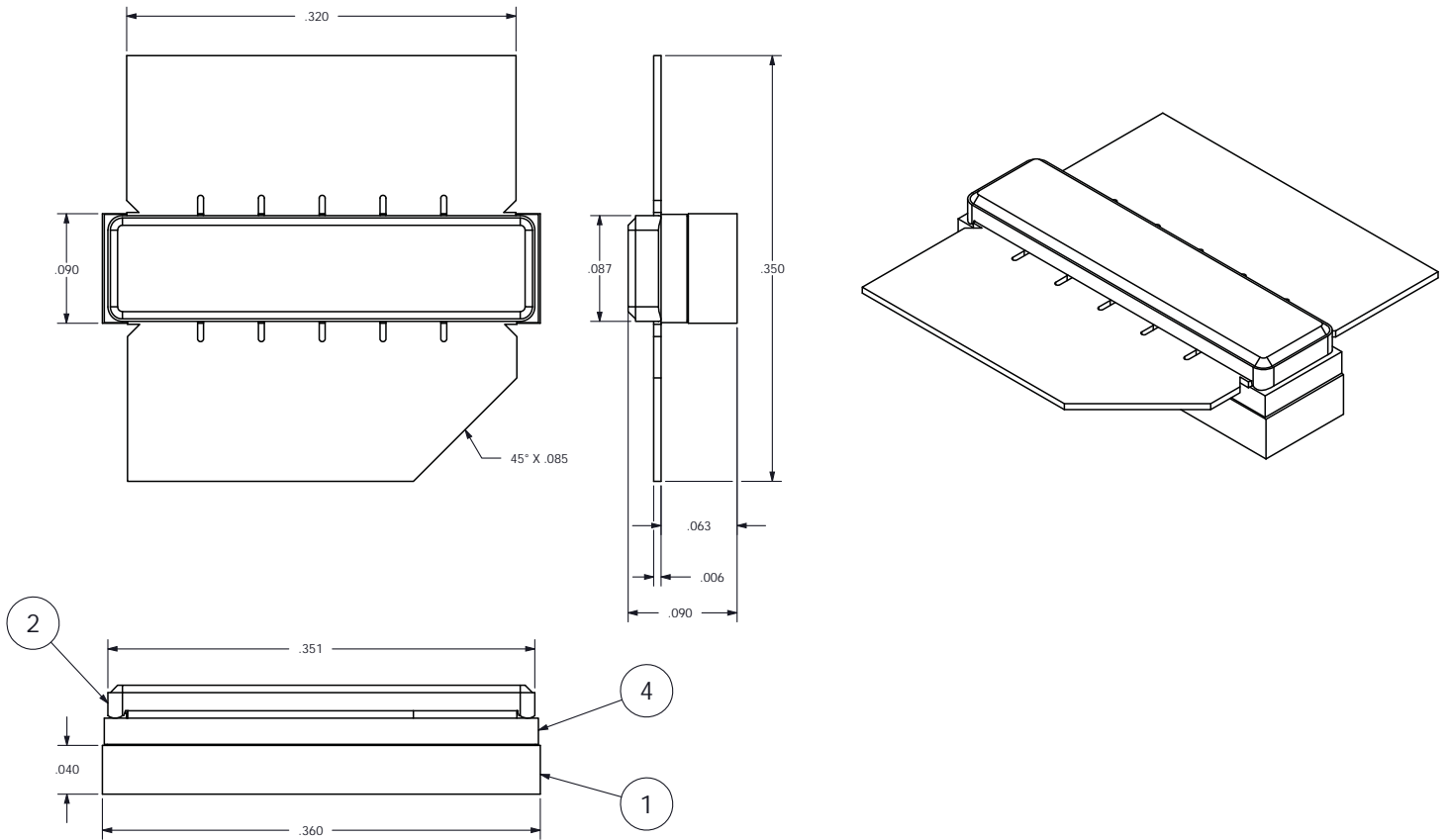

Preliminary Data Sheet
Subject to Change