

# 527-186 Split Backshell and Shorting Cap for Cannon DPKA and DPKB Series Connectors

**527-186 M 16 A 1 A**

Basic Part No. ———  
 Finish Symbol (Table III) ———  
 Dash No. (Table II, Note 3) ———  
 Connector Symbol (Table I) ———

Backshell Style: A or B (Style B Available on Connector Sym B Only), Omit for Shorting Backshell  
 1 = With RFI/EMI Gaskets,  
 2 = Without RFI/EMI Gaskets

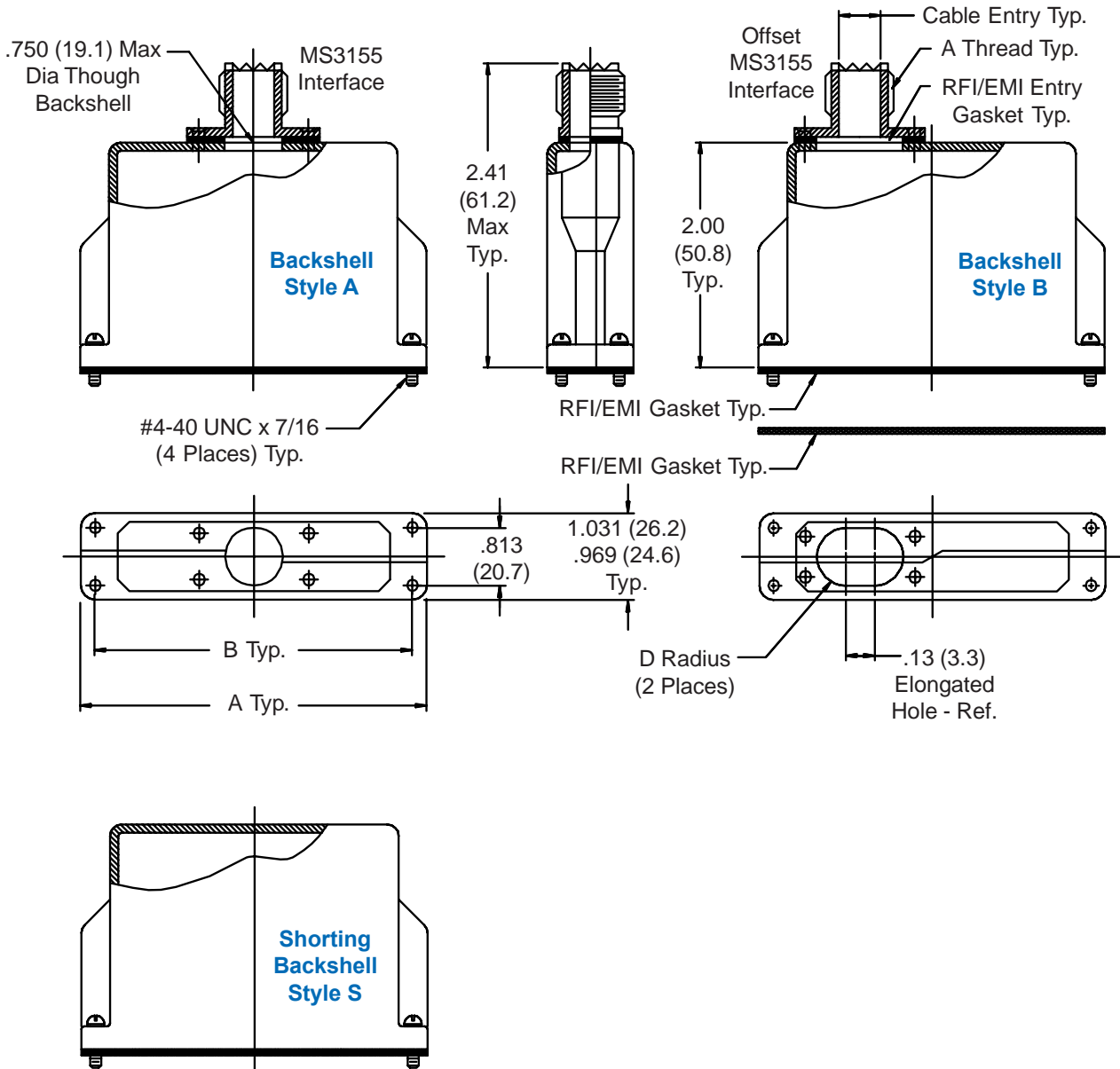

**527-186**  
**Split Backshell and Shorting Cap for**  
**Cannon DPKA and DPKB Series Connectors**



ARINC Series  
400 (Cannon)

**TABLE I: CONNECTOR INTERFACE DIMS**

Connector Symbol	Connector Series	A ±.062 (1.6)	B ±.005 (.1)
A	DPKA	2.095 (53.2)	1.895 (48.1)
B	DPKB/DPJM	3.395 (86.2)	3.195 (81.2)

**TABLE II: CABLE ENTRY**

Dash No.	A Thread Class 2A	Cable Entry Max	D Radius
00 *	n/a	n/a	n/a
08	1/2 - 30 UNF	.250 (6.4)	.125 (3.2)
10	5/8 - 24 UNF	.375 (9.5)	.188 (4.8)
12	3/4 - 20 UNEF	.500 (12.7)	.250 (6.4)
14	7/8 - 20 UNEF	.625 (15.9)	.312 (7.9)
16	1 - 20 UNEF	.750 (19.1)	.375 (9.5)
18	1 1/16 - 18 UNEF	.750 (19.1)	.375 (9.5)
20	1 3/16 - 18 UNEF	.750 (19.1)	.375 (9.5)

\* See Note 3

**TABLE III - FINISH OPTIONS**

Symbol	Finish
B	Cadmium Plate, Olive Drab
J	Iridite, Gold Over Cadmium Plate over Nickel
M	Electroless Nickel
N	Cadmium Plate, Olive Drab, Over Nickel
NF	Cadmium Plate, Olive Drab, Over Electroless Nickel (500 Hour Salt Spray)
T	Cadmium Plate, Bright Dip Over Nickel (500 Hour Salt Spray)

**CONSULT FACTORY FOR  
OTHER AVAILABLE FINISHES**

1. Metric dimensions (mm) are indicated in parentheses.
2. Backshell replaces connector rear bracket.
3. When Backshell Style S is ordered, insert "00" in place of Dash No.
4. Material/Finish:  
 Adapter and Backshell = Al Alloy/Table III  
 Hardware = SST/Passivate  
 Backshell and Entry Gaskets = Metalastic/N.A.  
 Interface Gasket = Monel Mesh/N.A.