

2-CH AUDIO POWER AMPLIFIER(25W X2)

DESCRIPTION

The SA7265 is a monolithic integrated circuit in HSIP package, intended for use as dual audio frequency class AB amplifier.

FEATURES

- * Wide supply voltage range up to 50V ABS MAX.
- * Split supply operation.
- * High output power: 25 + 25W @ THD=10%, $R_L=8\Omega$, $V_s=\pm 20V$
- * Mute/stand-by function.
- * Few external components.
- * Short circuit protection.
- * Thermal overload protection.

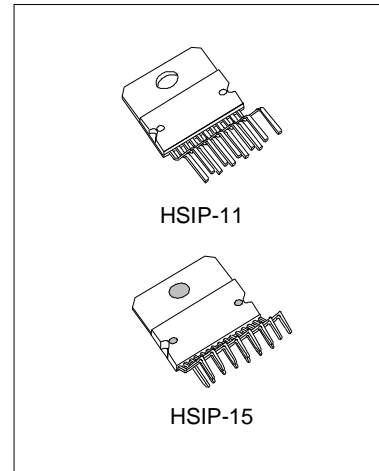

APPLICATIONS

- * Hi-Fi music centers
- * Stereo TV sets

ORDERING INFORMATION

Part No.	Package
SA7265	HSIP-11
SA7265A	HSIP-15

BLOCK DIAGRAM

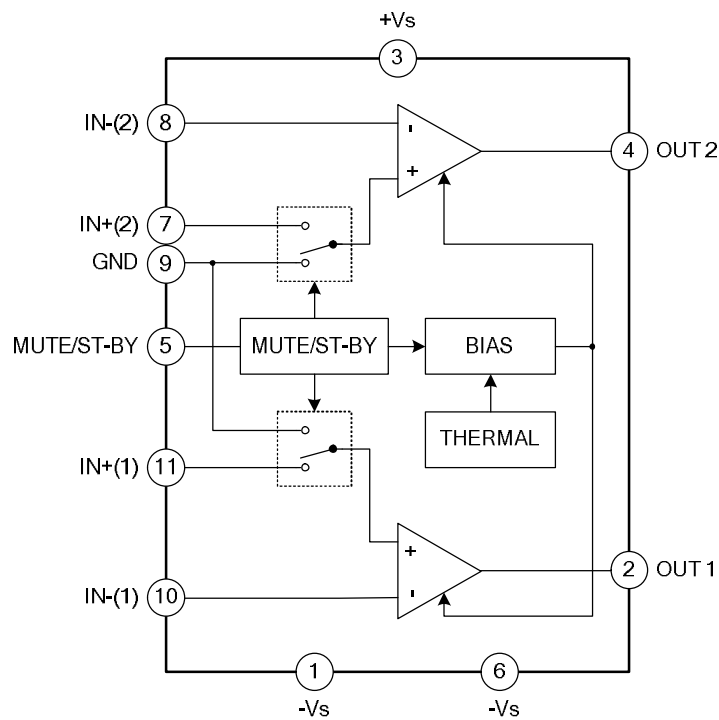

Note: Figures for the SA7265.

ABSOLUTE MAXIMUM RATING

Characteristics	Symbol	Rating	Unit
DC Supply Voltage	V _s	50 or ±25	V
Output Peak Current (Internally Limited)	I _o	4.5	A
Power Dissipation T _{case} =70°C	P _{tot}	30	W
Storage And Junction Temperature	T _{stg} , T _j	-40~+150	°C
Supply Voltage to Guarantee Short-circuit Protection	V _{s(sc)}	±18(*)	V
Thermal Resistance From Junction To Case (Max)	R _{th(j-c)}	2	°C/W

(*)Maximum supply voltage to guarantee short-circuit to ±V_s is ±18V, and to GND short-circuit protection is normal.

ELECTRICAL CHARACTERISTICS

(Refer to the test circuit, V_s±20V; R_L=8Ω; R_s=50Ω; G_v=30dB; f=1KHz; T_{amb}=25°C, unless otherwise specified.)

Characteristics	Symbol	Test conditions	Min.	Typ.	Max.	Unit
Supply Range	V _s		±5		±22.5	V
Total Quiescent Current	I _q			80	130	mA
Input Offset Voltage	V _{os}		-25		+25	mV
Non Inverting Input Bias Current	I _b			500		nA
Music Output Power*	P _{omax}	THD=10%; V _s =±22.5V; R _L =8Ω;		32		W
Output Power (Continuous RMS)	P _o	THD=10%; R _L =8Ω; V _s =±16V; R _L =4Ω	20	25 25		W W
		THD=1%; R _L =8Ω; V _s =±16V; R _L =4Ω		20 20		W W
Total Harmonic Distortion	THD	R _L =8Ω; P _o =1W; f=1KHz		0.02		%
		R _L =8Ω; P _o =0.1~15W; f=100Hz~15KHz			0.7	%
		R _L =4Ω; P _o =1W; f=1KHz		0.03		%
		R _L =4Ω; V _s =±16V; P _o =0.1~12W; f=100Hz~15KHz			1	%

(To be continued)

(Continued)

Characteristics	Symbol	Test conditions	Min.	Typ.	Max.	Unit
Cross Talk	CT	f=1KHz		70		dB
		f=10KHz		60		dB
Slew Rate	SR			10		V/ μ s
Open Loop Voltage Gain	GV			80		dB
Total Input Noise	eN	A curve f=20Hz~22KHz		3		μ V
				4	8	μ V
Input Resistance	Ri		15	20		K Ω
Supply Voltage Rejection (each channel)	SVR	Fr=100Hz; Vripple=0.5Vrms		60		dB
Thermal Shut-down Junction Temperature	Tj			145		$^{\circ}$ C
Mute Function [ref: +Vs]						
Mute /Play Threshold	VTMUTE		-7	-6	-5	V
Mute Attenuation	AMUTE		60	70		dB
Stand-by Function [ref: +Vs]						
Stand-by /Mute Threshold	VTST-BY		-3.5	-2.5	-1.5	V
Stand-by Attenuation	AST-BY			110		dB
Quiescent Current @ Stand-by	Iq ST-BY			3		mA

Note:

* Music Output Power is the maximal power which the amplifier is capable of producing across the rated load resistance (regardless of non linearity) 1 sec after the application of a sinusoidal input signal of frequency 1KHz.

According to this definition, the method of measurement comprises the following steps:

- 1) Set the voltage supply at the maximum operating value -10%
- 2) Apply a input signal in the form of a 1KHz tone burst of 1 sec duration; the repetition period of the signal pulses is > 60 sec
- 3) The output voltage is measured 1 sec from the start of the pulse
- 4) Increase the input voltage until the output signal show a THD = 10%
- 5) The music power is then V_{out}^2/RL , where V_{out} is the output voltage measured in the condition of point 4) and R1 is the rated load impedance

The target of this method is to avoid excessive dissipation in the amplifier.

PIN CONFIGURATION

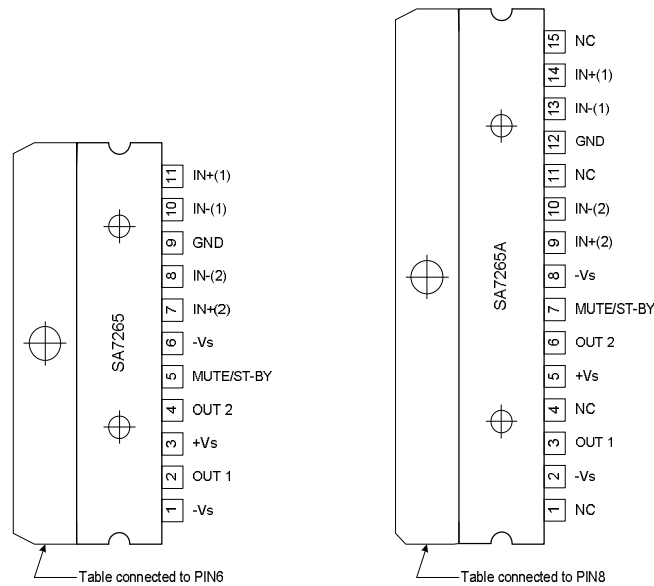

PIN DESCRIPTION

Pin No.		Pin Name	Pin Description
HSIP-11	HSIP-15		
1	2	-Vs	Negative power
2	3	OUT 1	Output1
3	5	+Vs	Positive power
4	6	OUT 2	Output2
5	7	MUTE / ST-BY	Mute /stand-by function
6	8	-Vs	Negative power
7	9	IN+(2)	Inverting Input 2
8	10	IN-(2)	Non inverting input 2
9	12	GND	Ground
10	13	IN-(1)	Non inverting input 1
11	14	IN+(1)	Inverting input 1
	1,4,11,15	NC	Not connected

FUNCTION DESCRIPTION

MUTE AND STAND-BY FUNCTION

The pin 5 (MUTE/STAND-BY) controls the amplifier status by two different thresholds, referred to +Vs.

- When V_{pin5} higher than $+Vs - 2.5V$ the amplifier is in Stand-by mode and the final stage generators are off
- When V_{pin5} is between $+Vs - 2.5V$ and $+Vs - 6V$ the final stage current generators are switched on and the amplifier is in mute mode
- When V_{pin5} is lower than $+Vs - 6V$ the amplifier is play mode.

BRIDGE APPLICATION

Another application suggestion concerns the BRIDGE configuration, where the two power amplifiers are connected as shown by the schematic diagram of the following.

This application shows, however, some operative limits due to dissipation and current capability of the output stage. For this reason, we recommend to use the SA7265 in bridge with the supply voltage equal/lower than $\pm 16V$ when the load is 8Ω ; with higher loads (i.e. 16Ω), the amplifier can work correctly in the whole supply voltage range.

With $R_L=8\Omega$, $V_s=\pm 16V$ the maximum output power obtainable is $50W$ at $TDH=10\%$. The quiescent current remains unchanged with respect to the stereo configuration ($\sim 80mA$ as typical at $V_s=\pm 16V$).

The last point to take into consideration concerns the short-circuit protection. As for the stereo application, the SA7265 is fully protected against any kind of short-circuit (between Out/Gnd, Out/+Vs and Out/-Vs).

Power Dissipation and Heat Sinking

The SA7265 must always be operated with a heat sink, even when it is not required to drive a load. The idling current of the device is $80mA$, so that on a $\pm 20V$ power supply an unloaded SA7265 must dissipate about $3W$ of power. The $54^{\circ}C/W$ junction-to-ambient thermal resistance of a HSIP-11 package would cause the die temperature to rise $162^{\circ}C$ above ambient, so the thermal protection circuitry will shut the amplifier down if operation without a heat sink is attempted.

In order to determine the appropriate heat sink for a given application, the power dissipation of the SA7265 in that application must be known. When the load is resistive, the maximum average power that the IC will be required to dissipate is approximately:

$$PD(MAX)=V_s^2/\pi^2 R_L+PQ$$

Where V_S is the total power supply voltage across the SA7265, R_L is the load resistance PQ is the quiescent power dissipation of the amplifier. The above equation is only an approximation which assume an "ideal" class B output stage and constant power dissipation in all other parts of the circuit. The curves of "Power Dissipation vs. Power Output" give a better representation of the behaviour of the SA7265 with various power supply voltages and resistive loads. As an example, if the SA7265 is operated on a $\pm 20V$ power supply with a resistive load of 8Ω , it can develop up to $23W$ of internal power dissipation. If the die temperature is to remain below $150^{\circ}C$ for ambient temperatures up to $50^{\circ}C$, the total junction-to-ambient thermal resistance must be less than:

$$(150^{\circ}C-50^{\circ}C)/23W=4.3^{\circ}C/W$$

Using $R_{th(j-c)} = 2^{\circ}C/W$, the sum of the case-to-heat-sink interface thermal resistance and the heat-sink-to-ambient thermal resistance must be less than $2.3^{\circ}C/W$. The case-to-heat-sink thermal resistance of the HSIP-11 package varies with the mounting method used. A metal-to-metal interface will be about $1^{\circ}C/W$ if lubricated, and about $1.2^{\circ}C/W$ if dry.

If a mica insulator is used, the thermal resistance will be about $1.6^{\circ}C/W$ lubricated and $3.4^{\circ}C/W$ dry. For this example, we assume a lubricated mica insulator between the SA7265 and the heat sink. The heat sink thermal resistance must then be less than:

$$4.3^{\circ}C/W-2^{\circ}C/W-1.6^{\circ}C/W=0.7^{\circ}C/W$$

This is a rather large heat sink and may not be practical in some applications. If a smaller heat sink is required for reasons of size or cost, there is an alternative. The heat sink can be isolated from the chassis so the mica washer is not needed. This will change the required heat sink to a $1.3^{\circ}C/W$ unit if the case-to-heat-sink interface is lubricated.

The thermal requirements can become more difficult when an amplifier is driving a reactive load. For a given

magnitude of load impedance, a higher degree of reactance will cause a higher level of power dissipation within the amplifier. As a general rule, the power dissipation of an amplifier driving a 60° reactive load (usually considered to be a worst-case loudspeaker load) will be roughly that of the same amplifier driving the resistive part of that load. For example, a loudspeaker may at some frequency have an impedance with a magnitude of 8Ω and a phase angle of 60°. The real part of this load will then be 4Ω, and the amplifier power dissipation will roughly follow the curve of power dissipation with a 4Ω load.

TYPICAL APPLICATION CIRCUIT IN SPLIT SUPPLY

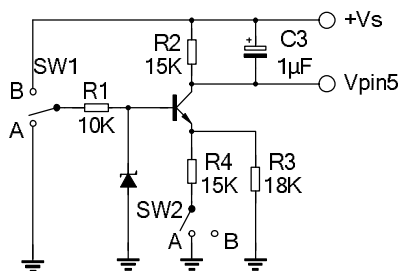
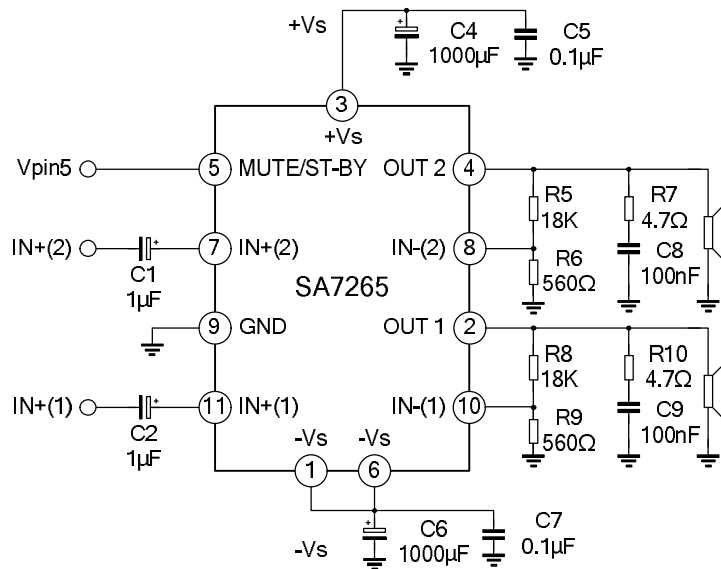

SW1	SW2	
A	A	Stand-by
A	B	Stand-by
B	B	Mute
B	A	Play

Note: Figures for the SA7265.

TYPICAL APPLICATION CIRCUIT IN SINGLE SUPPLY

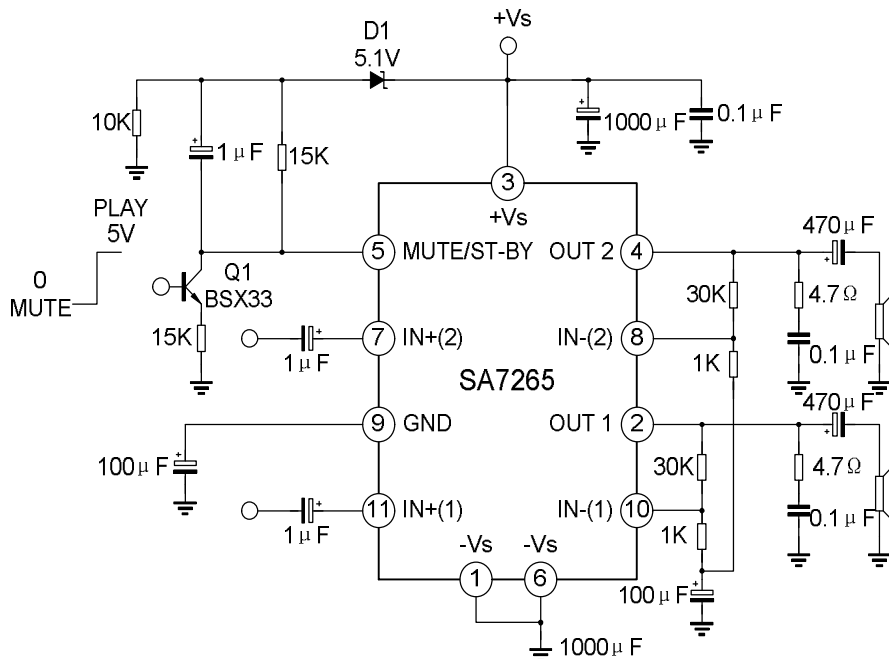

Note: Figures for the SA7265.

TYPICAL BRIDGE APPLICATION CIRCUIT IN SPLIT SUPPLY

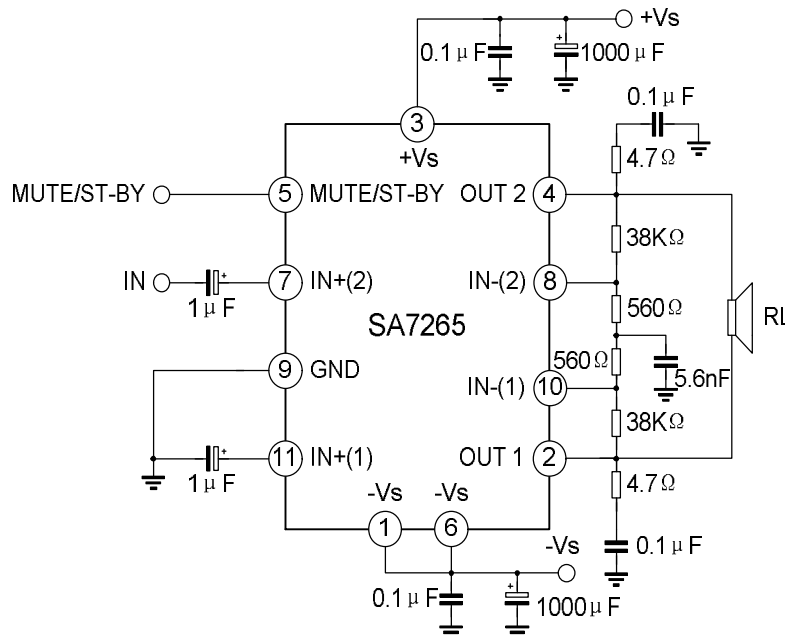

Note: Figures for the SA7265.

ELECTRICAL CHARACTERISTICS CURVES

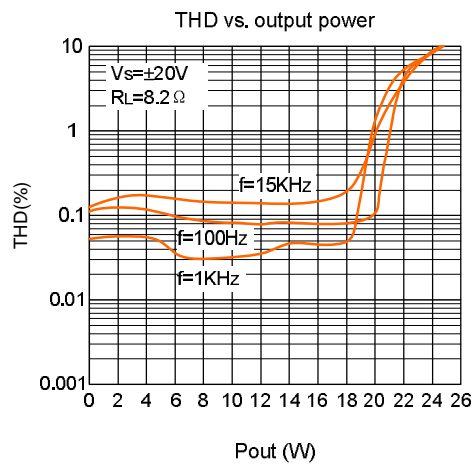
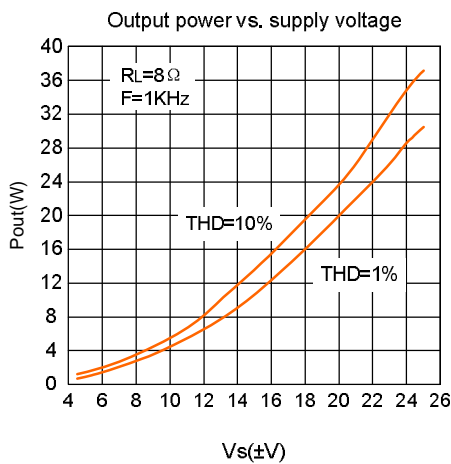
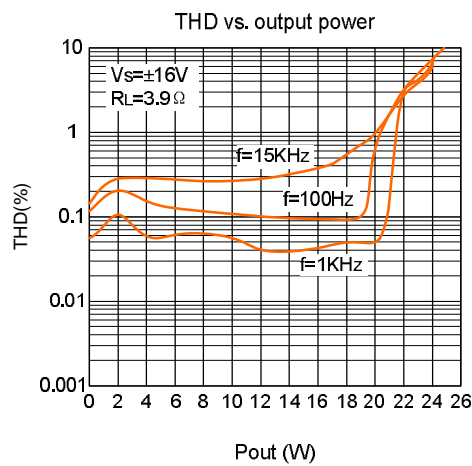
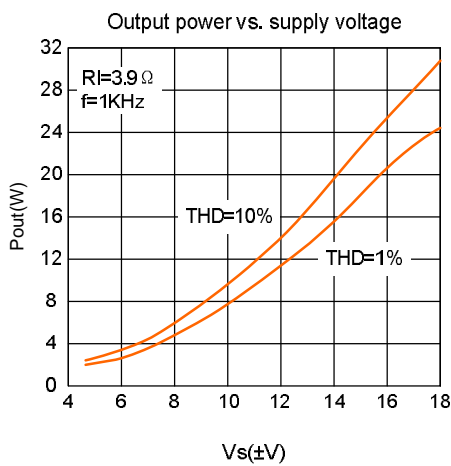
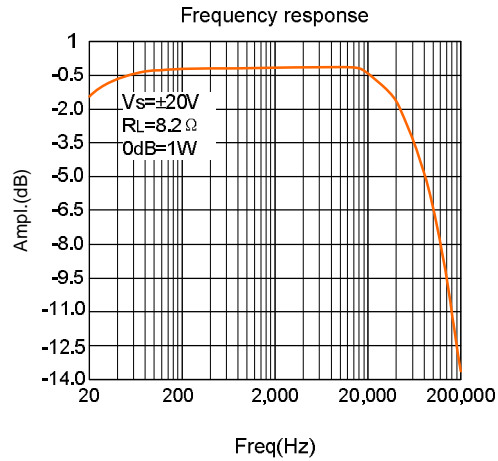
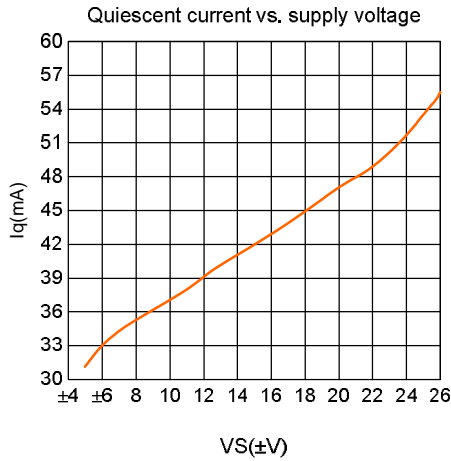

(To be continued)

(Continued)

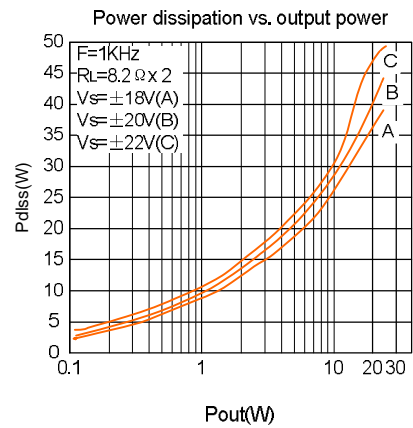
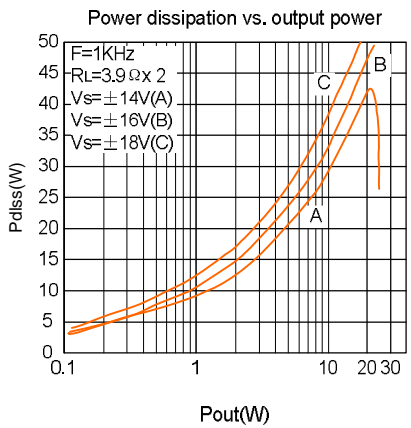
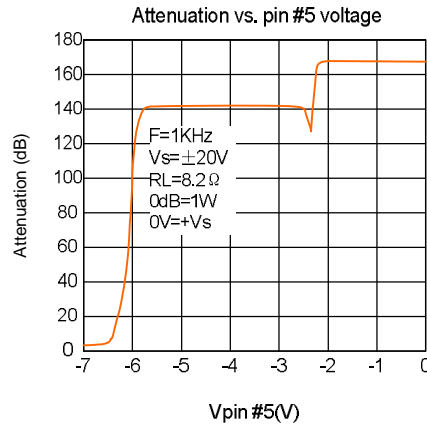
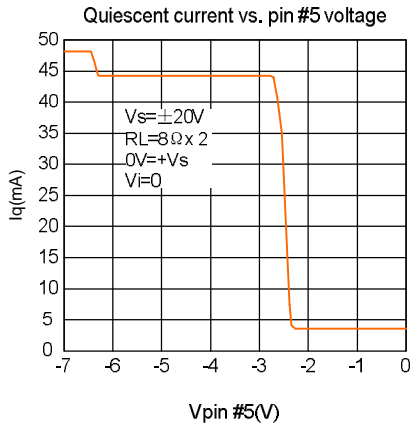

PC BOARD AND COMPINENTS LAYOUT OF THE TYPICAL APPLICATION IN SPLIT SUPPLY

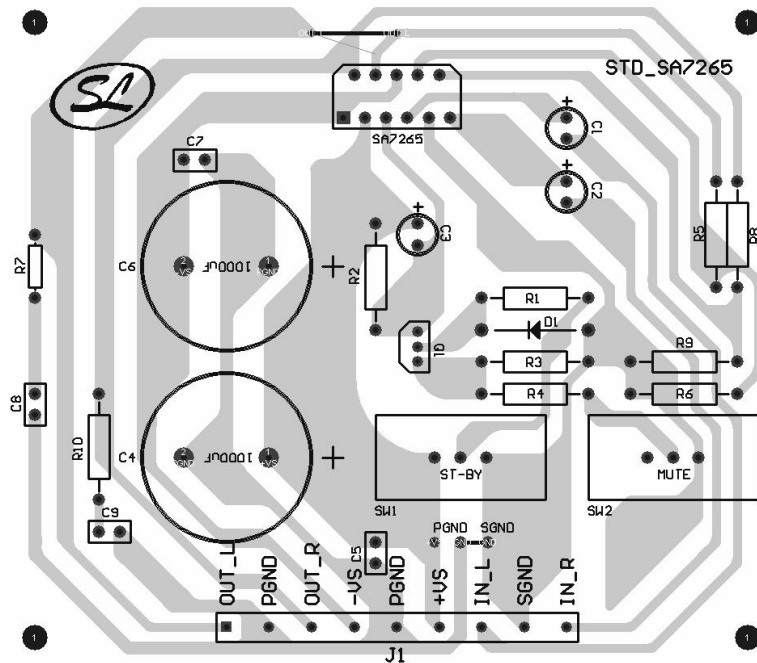

APPLICATION SUGGEST

The recommended values of the external components are those shown are the **Typical Application Circuit in Split Supply**:

COMPONENTS	RECOMMENDED VALUE	PURPOSE	LARGER THAN RECOMMENDED VALUE	SMALLER THAN RECOMMENDED VALUE
R1	10K Ω	Mute Circuit	Increase of Dz Biasing Current	
R2	15K Ω	Mute Circuit	VMUTE/STBY Shifted Downward	VMUTE/STBY Shifted Upward
R3	18K Ω	Mute Circuit	VMUTE/STBY Shifted Upward	VMUTE/STBY Shifted Downward
R4	15K Ω	Mute Circuit	VMUTE/STBY Shifted Upward	VMUTE/STBY Shifted Downward
R5, R8	18K Ω	Closed Loop Gain Setting*	Increase of Gain	
R6, R9	560 Ω		Decrease of Gain	
R7 R10	4.7 Ω	Frequency Stability	Danger of Oscillations	Danger of Oscillations
C1, C2	1 μ F	Input DC Decoupling		Higher Low Frequency Cutoff
C3	1 μ F	St-By/Mute Time Constant	Larger On/Off Time	Smaller On/Off Time
C4, C6	1000 μ F	Supply Bypass		Danger of Oscillations
C5, C7	0.1 μ F	Supply Bypass		Danger of Oscillations
C8, C9	0.1 μ F	Frequency Stability		
Dz	5.1V	Mute Circuit		
Q1	BC107	Mute Circuit		

* Closed loop gain has to be ≥ 25 dB

PACKAGE OUTLINE

HSIP-11

Unit: mm

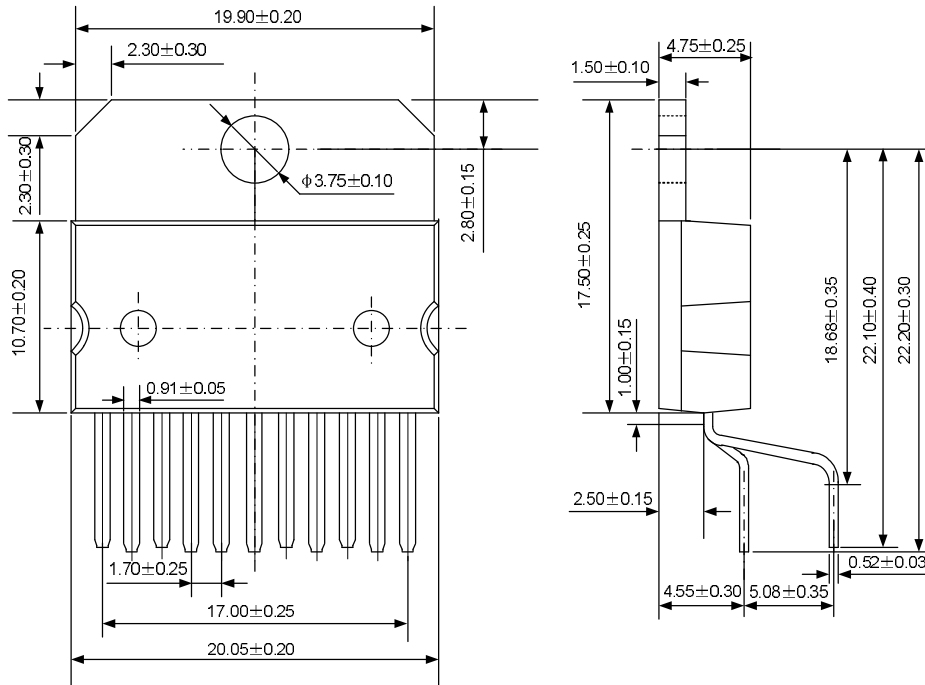

HSIP-15

Unit: mm

