

PLEASE CHECK WWW.MOLEX.COM FOR LATEST PART INFORMATION

Part Number: **0190130028**
Status: **Active**
Description: InsulKrimp™ Fully Insulated Piggyback Quick Disconnect, Tab 6.35mm (.250") by 0.81mm (.032"), 18-22 AWG, Expanded Flare, Red Insulator, Tape

Documents:

[Drawing \(PDF\)](#) [RoHS Certificate of Compliance \(PDF\)](#)
[Product Specification PS-19902-008 \(PDF\)](#)

Agency Certification

CSA LR18689
 UL E79133

General

Product Family Quick Disconnects
 Series 19013
 Crimp Quality Equipment Yes
 Product Name InsulKrimp™
 Type Quick Disconnect

Physical

Barrel Type Closed - Brazed
 Color - Resin Natural
 Flammability 94V-2
 Gender Female
 Glow-Wire Compliant No
 Insulation Nylon (PA)
 Lock to Mating Part No
 Material - Resin Nylon
 Orientation Straight
 Packaging Type Adhesive Tape on Reel
 Polarized to Mating Part Yes
 Tab Thickness 0.81mm (.032")
 Tab Width 6.35mm (.250")
 Temperature Range - Operating 105°C
 Wire Insulation Diameter 5.82mm (.229") max.
 Wire Size AWG 18, 20, 22
 Wire Size mm² 0.35 - 0.80

Electrical

Voltage - Maximum 600V AC

Material Info

Old Part Number AA-2317XT

Reference - Drawing Numbers

Product Specification PS-19902-008
 Sales Drawing SD-19013-002

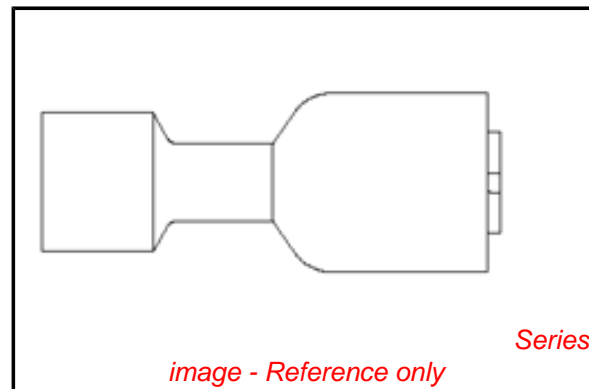

EU RoHS

ELV and RoHS Compliant
REACH SVHC
 Not Reviewed
Halogen-Free Status

China RoHS



Need more information on product environmental compliance?

Email productcompliance@molex.com
 For a multiple part number RoHS Certificate of Compliance, [click here](#)

Please visit the [Contact Us](#) section for any non-product compliance questions.

Search Parts in this Series

19013Series

Application Tooling | FAQ

Tooling specifications and manuals are found by selecting the products below. Crimp Height Specifications are then contained in the Application Tooling Specification document.

Global

Description	Product #
Mini-Mac™ Applicator	0638852300
Hand Crimp Tool	0640016300
Crimp Head for the AT-200™ Pneumatic Hand Tool	0640056300

MATERIAL NO. LOOSE PC	ENGINEERING NO. LOOSE PC	MATERIAL NO. ON TAPE	ENGINEERING NO. ON TAPE	WIRE SIZE	INSULATOR COLOR	ID MIN REF	MWID	D MAX	L MAX	H NOMINAL
190130027	AA-2317X	190130028	AA-2317XT	22-18 AWG	RED	.056/1.42	.229/5.82	.380/9.65	.940/23.88	.54/13.7
190130031	BB-2318X	190130032	BB-2318XT	16-14 AWG	BLUE	.081/2.06	.259/6.58	.380/9.65	.940/23.88	.54/13.7

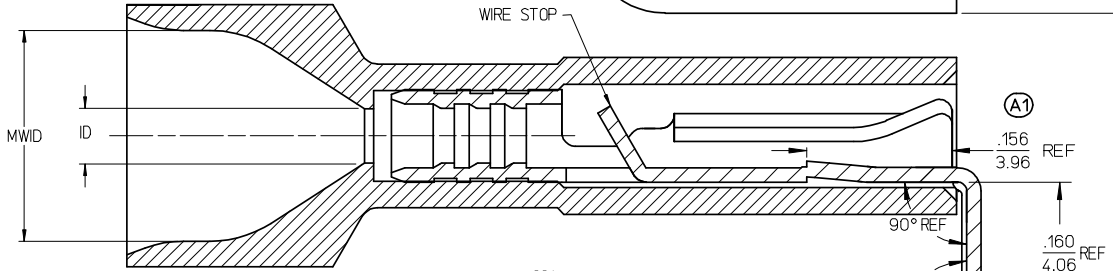
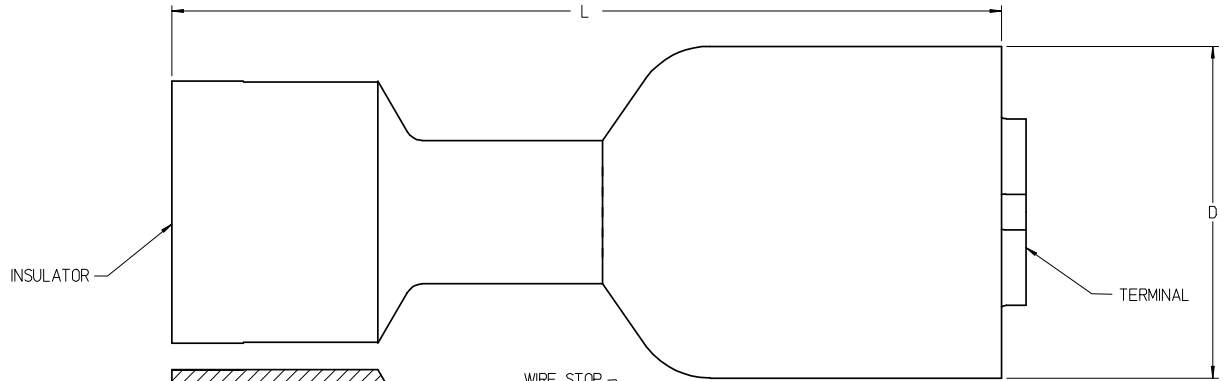

TYP ALL MATERIAL NUMBERS
SINGLE SPACED
CENTER TO CENTER

TAB AWAY FROM TAPE

.60 REF
15.2

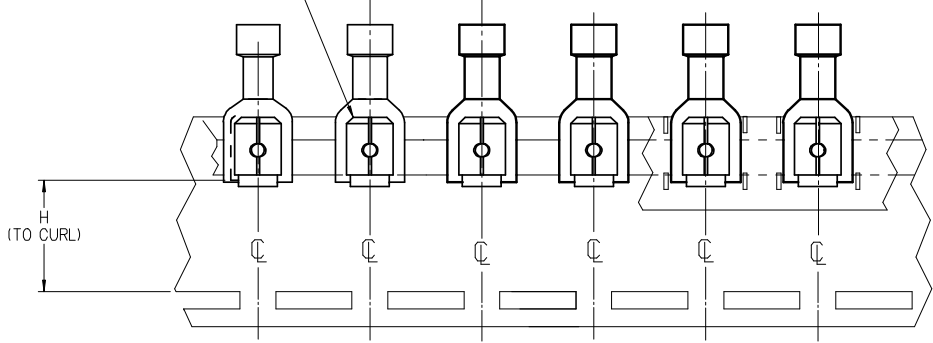

PARTS ON TAPE (SCALE 2:1)

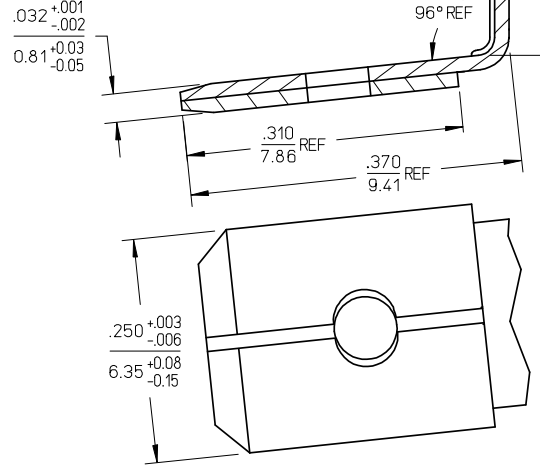

NOTES:

1. TERMINAL MATERIAL: BRASS
2. TERMINAL FINISH: TIN PLATED
3. INSULATOR MATERIAL: NYLON
4. MWID = MAXIMUM WIRE INSULATION DIAMETER.
5. ASSEMBLY IS ROHS COMPLIANT.

ADD TAPE DIAGRAM EC NO: WNA 2008-0032 DRAWN: THRODAHL 2008/02/14 CHKD: JMACNEIL 2008/03/11 APPR: JMACNEIL 2008/03/11	QUALITY SYMBOLS	GENERAL TOLERANCES (UNLESS SPECIFIED)	DIMENSION STYLE	SCALE	DESIGN UNITS	THIRD ANGLE PROJECTION																		
	$\nabla=0$ $\nabla=0$	<table border="1"> <tr> <th></th> <th>mm</th> <th>INCH</th> </tr> <tr> <td>4 PLACES</td> <td>±---</td> <td>±---</td> </tr> <tr> <td>3 PLACES</td> <td>±---</td> <td>±---</td> </tr> <tr> <td>2 PLACES</td> <td>±---</td> <td>±---</td> </tr> <tr> <td>1 PLACE</td> <td>±---</td> <td>±---</td> </tr> <tr> <td colspan="3">ANGULAR ±---°</td> </tr> </table>		mm	INCH	4 PLACES	±---	±---	3 PLACES	±---	±---	2 PLACES	±---	±---	1 PLACE	±---	±---	ANGULAR ±---°			IN/MM	10:1	INCH	
		mm	INCH																					
	4 PLACES	±---	±---																					
3 PLACES	±---	±---																						
2 PLACES	±---	±---																						
1 PLACE	±---	±---																						
ANGULAR ±---°																								
DESCRIPTION	DRAWN BY	DATE	TITLE	MOLEX INCORPORATED																				
REV	APPROVED BY	DATE	DOCUMENT NO.	SD-19013-002																				

DRAFT WHERE APPLICABLE MUST REMAIN WITHIN DIMENSIONS

SEE CHART

THIS DRAWING CONTAINS INFORMATION THAT IS PROPRIETARY TO MOLEX INCORPORATED AND SHOULD NOT BE USED WITHOUT WRITTEN PERMISSION