

PLEASE CHECK WWW.MOLEX.COM FOR LATEST PART INFORMATION

Part Number: **0513380774**
Status: **Active**
Description: 0.40mm (.016") Pitch Board-to-Board SlimStack™ Receptacle, Surface Mount, Dual Row, Vertical Stacking, 1.50mm (.059") Stacking Height, with Space Saving J-Bend Leads, 70 Circuits, Lead-free

Documents:

[3D Model](#) [Product Specification PS-51338-002 \(PDF\)](#)
[Drawing \(PDF\)](#) [RoHS Certificate of Compliance \(PDF\)](#)

General

Product Family PCB Receptacles
 Series 51338
 Application Board-to-Board
 Comments Solder Tab Plating: Tin (Sn) over Nickel
 Product Name SlimStack™

Physical

Circuits (Loaded) 70
 Circuits (maximum) 70
 Color - Resin Black
 Durability (mating cycles max) 30
 Glow-Wire Compliant No
 Lock to Mating Part Yes
 Mated Height (in) 0.059 In
 Mated Height (mm) 1.50 mm
 Material - Metal Phosphor Bronze
 Material - Plating Mating Gold
 Material - Plating Termination Gold
 Number of Rows 2
 Orientation Vertical
 PCB Locator No
 PCB Retention None
 Packaging Type Embossed Tape on Reel
 Pitch - Mating Interface (in) 0.016 In
 Pitch - Mating Interface (mm) 0.40 mm
 Polarized to Mating Part No
 Polarized to PCB No
 Stackable No
 Surface Mount Compatible (SMC) Yes
 Temperature Range - Operating -25°C to +85°C
 Termination Interface: Style Surface Mount

Electrical

Current - Maximum per Contact 0.3A
 Voltage - Maximum 50V AC (RMS)/DC

Material Info

Reference - Drawing Numbers

Packaging Specification SPK-51338-001
 Product Specification PS-51338-002, RPS-51338-007, RPS-51338-008, RPS-51338-012, RPS-51338-013, RPS-51338-018, RPS-51338-019, RPS-51338-020, RPS-51338-022, RPS-51338-025, RPS-51338-027, RPS-51338-030, RPS-51338-031
 Sales Drawing SD-51338-003, SD-51338-004

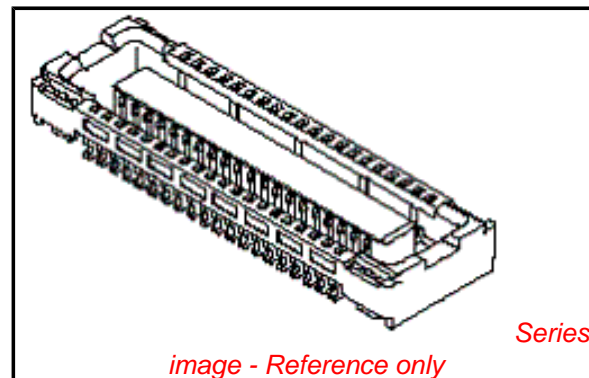

EU RoHS

ELV and RoHS Compliant
REACH SVHC Contains SVHC: No
Halogen-Free Status
Not Reviewed

China RoHS



Need more information on product environmental compliance?

Email productcompliance@molex.com
 For a multiple part number RoHS Certificate of Compliance, [click here](#)

Please visit the [Contact Us](#) section for any non-product compliance questions.

Search Parts in this Series

[51338Series](#)

Mates With

[55909 PCB Header](#)

This document was generated on 04/26/2010

PLEASE CHECK WWW.MOLEX.COM FOR LATEST PART INFORMATION

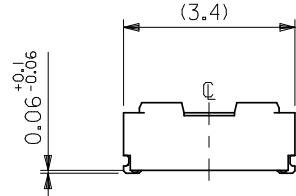
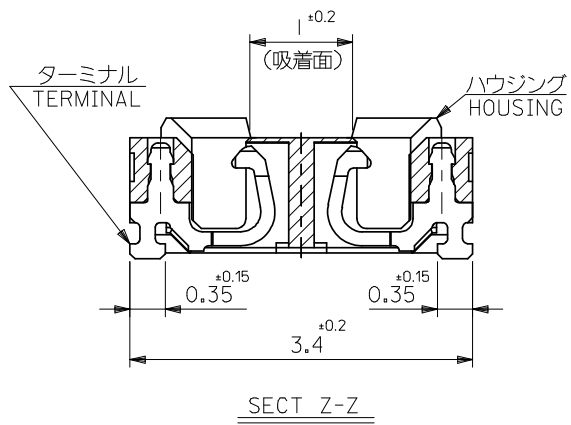
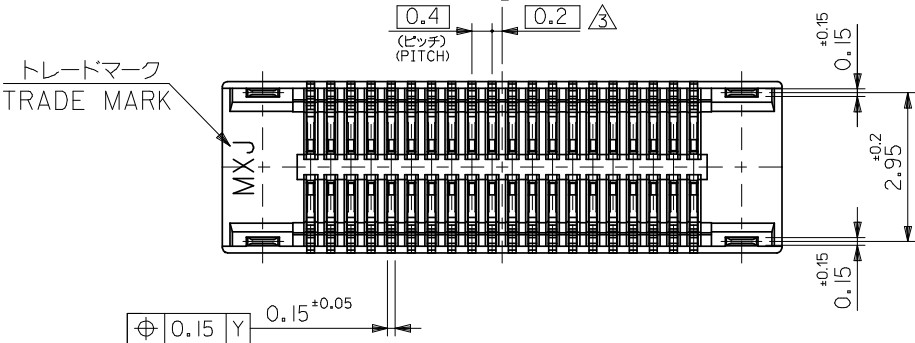
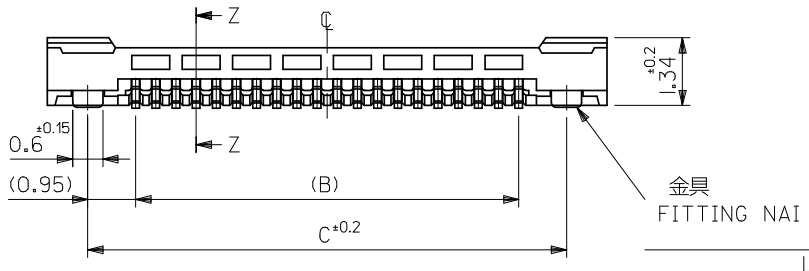
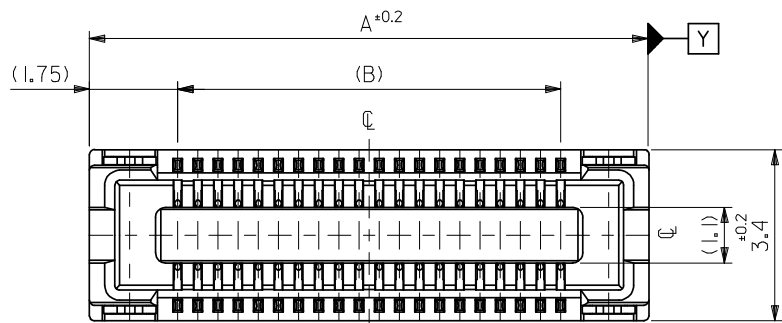

25.5	23.6	27.1	51338-1274	51338-1209	120
21.5	19.6	23.1	51338-1074	51338-1009	100
19.5	17.6	21.1	51338-0974	51338-0909	90
17.5	15.6	19.1	51338-0874	51338-0809	80
15.5	13.6	17.1	51338-0774	51338-0709	70
13.5	11.6	15.1	51338-0674	51338-0609	60
11.5	9.6	13.1	51338-0574	51338-0509	50
9.5	7.6	11.1	51338-0474	51338-0409	40
8.3	6.4	9.9	51338-3474	51338-0349	34
7.5	5.6	9.1	51338-0374	51338-0309	30
6.7	4.8	8.3	51338-2674	51338-0269	26
6.3	4.4	7.9	51338-2474	51338-0249	24
5.9	4.0	7.5	51338-2274	51338-0229	22
5.5	3.6	7.1	51338-0274	51338-0209	20
3.9	2.0	5.5	51338-9974	51338-0129	12
C	B	A	EMBOSSED TAPE PKG. ORDER No. オオーダー番号	MATERIAL No.	CKT.

REVISED EC NO.: J2009-0301 DRWN: MWABEI 2008/08/27 CHKD: THARUYAMA 2008/08/28 APPR: NUKITA 2008/08/28	GENERAL TOLERANCES (UNLESS SPECIFIED)		DIMENSION STYLE MM ONLY		SCALE ---	DESIGN UNITS METRIC	MODEL NO. 51338-***9
	10 UNDER	±---	DRAWN BY M. NINOMIYA	DATE 2004/03/17	TITLE 0.4 B-TO-B REC ASSY HGT=1.5 J-BEND TAIL -LEAD FREE-		
	10 OVER 30 UNDER	±---	CHECKED BY K. TOJO	DATE 2004/03/17	THIRD ANGLE PROJECTION		
	30 OVER	±---	APPROVED BY M. SASAO	DATE 2004/03/17	MOLEX INCORPORATED		
REV	DESCRIPTION	ANGULAR DRAFT WHERE APPLICABLE MUST REMAIN WITHIN DIMENSIONS	MATERIAL NO.	SEE TABLE	DOCUMENT NO. SD-51338-003	SHEET NO. 1 OF 2	

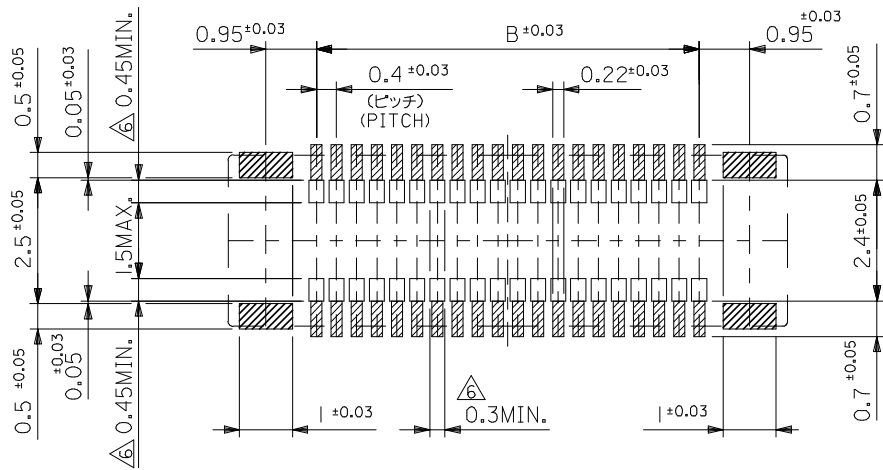

参考基板レイアウト (マウント面)
P.C.BOARD PATTERN DIMENSION (REFERENCE)
(MOUNTING AREA)

注記 NOTES:

1. 使用材料 MATERIAL
ハウジング: 液晶ポリマー (LCP) ガラス充填 UL94V-0 (黒)
HOUSING: LIQUID CRYSTAL POLYMER (GLASS FILLED)
UL94V-0 (COLOR: BLACK)
ターミナル: リン青銅 (t=0.15)
TERMINAL: PHOSPHOR BRONZE (t=0.15)
金具: リン青銅 (t=0.15)
FITTING NAIL: PHOSPHOR BRONZE (t=0.15)
2. メッキ仕様 PLATING
ターミナル TERMINAL
金メッキ 0.2マイクロメートル以上 (コンタクト部)
GOLD 0.2MICROMETER MINIMUM (CONTACT AREA)
金メッキ 0.4マイクロメートル以下 (テール部)
GOLD 0.4MICROMETER MAXIMUM (TAIL AREA)
下地メッキ: ニッケルメッキ 1.5マイクロメートル以上
UNDER PLATING: NICKEL 1.5MICROMETER MINIMUM
*コンタクト部とテール部はニッケルメッキによって分断されている金メッキです。
DIVIDE INTO PARTS THE GOLD PLATING OF THE CONTACT AND THE TAIL PART BY THE NICKEL PLATING.
金具 FITTING NAIL
錫メッキ 1.0 マイクロメートル以上
TIN PLATING 1.0 MICROMETER MINIMUM
下地メッキ: ニッケルメッキ 1.0 マイクロメートル以上
UNDER PLATING: NICKEL 1.0 MICROMETER MINIMUM
3. (全極数/2) = 偶数の場合に適用。
APPLY FOR (CIRCUIT/2)=EVEN.
4. 嵌合相手: 55909シリーズ
MATE WITH: 55909 SERIES.
5. テール平坦度は、0.08以下
テール及び金具の平坦度は、0.1以下
TAIL COPLANARITY TO BE 0.08MAXIMUM
TAIL AND FITTING NAIL COPLANARITY TO BE 0.1MAXIMUM
6. 同一回路以外のパターン書込み禁止範囲を示す。
NO PRINT CIRCUIT AREA OTHER THAN THE SAME CIRCUIT.
7. 本製品は 51338-***3 の鉛フリー品である。
THIS PRODUCT IS LEAD FREE OF 51338-***3.

REVISED EC NO: J2009-0301 DRAWN: MABEI 2008/08/27 CHKD: THARUYAMA 2008/08/28 APPR: NUKITA 2008/08/28	GENERAL TOLERANCES (UNLESS SPECIFIED)		DIMENSION STYLE MM ONLY		51338-***9		MODEL NO.	
	10 UNDER	±---	DRAWN BY	DATE	SCALE	DESIGN UNITS	THIRD ANGLE PROJECTION	
	10 OVER 30 UNDER	±---	M. NINOMIYA	2004/03/17	---	METRIC	0.4 B-TO-B REC ASSY HGT=1.5 J-BEND TAIL -LEAD FREE-	
	30 OVER	±---	K. TOJO	2004/03/17	TITLE		MOLEX INCORPORATED	
ANGULAR	±---°	APPROVED BY	DATE	MATERIAL NO.		DOCUMENT NO.	SHEET NO.	
DRAFT WHERE APPLICABLE MUST REMAIN WITHIN DIMENSIONS		M. SASAO		2004/03/17	SEE SHEET 1		SD-51338-003	2 OF 2
THIS DRAWING CONTAINS INFORMATION THAT IS PROPRIETARY TO MOLEX INCORPORATED AND SHOULD NOT BE USED WITHOUT WRITTEN PERMISSION								

NOTES

- 製品詳細寸法については製品単体図面を参照下さい。
RE DETAILED DIMENSION, SEE PRODUCT DRAWING.
- 梱包数量：2500個/リール
NUMBER OF CONNECTORS : 2500PCS/REEL
- リードテープ長さ LEAD TAPE LENGTH

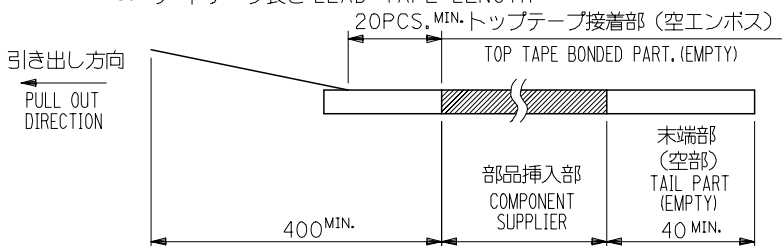

- トップテープの剥離強度：0.1N～1.3N(10gf～130gf)
(剥離方向は下図参照)
尚、本規格値は出荷時に適用。(但し、輸送時に剥離が発生しないこと。)
PEELING OFF FORCE OF TOP TAPE : 0.1N～1.3N(10gf～130gf)
(PEELING DIRECTION AS SHOWN IN FOLLOWING FIG.)
THIS REQUIREMENT SHOULD BE APPLIED AT SHIPMENT.
PEEL OFF SHOULD NOT BE ALLOWED, DURING TRANSPORTATION.

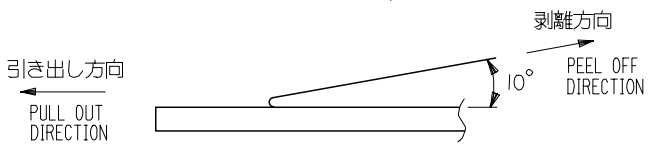

- 材料
キャリアテープ (CARRIER TAPE) : ポリプロピレン (POLYPROPYLENE)
トップテープ (TOPTAPE) : PET, PE, PEF
リール (REEL) : ポリスチレン (PS) <リサイクル材を含む>
POLYSTYRENE (PS) <RECYCLE MATERIAL CONTAINED>
- 本製品は 51338-***4 の鉛フリー品である。
THIS PRODUCT IS LEAD FREE OF 51338-***4.

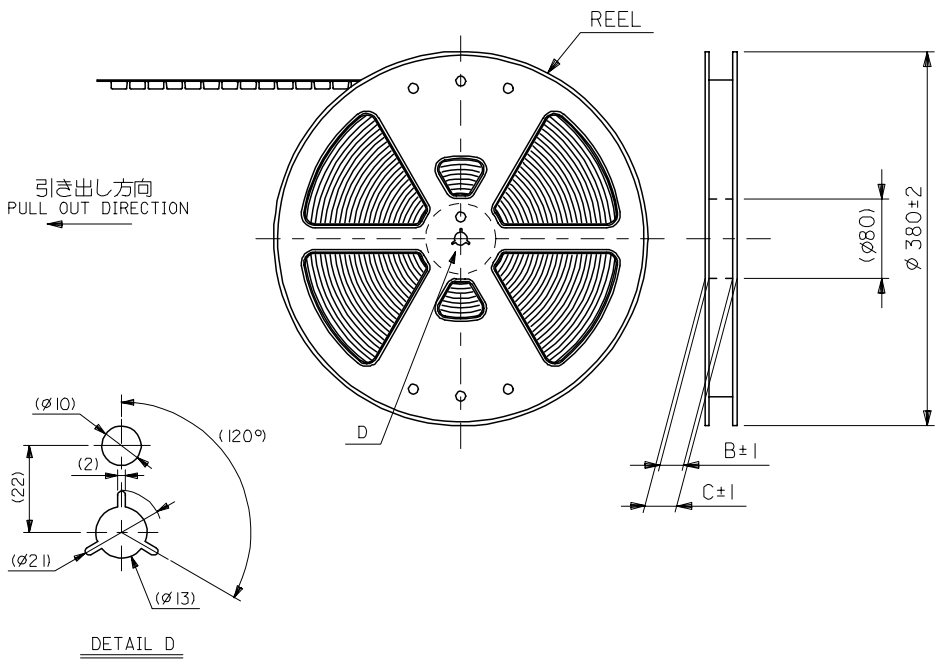

REVISED EC NO: J2006-0826 DRWN: TAKEMOTO 2005/09/30 CHKD: 2005/09/30 APPR: NUKITA 2005/09/30	GENERAL TOLERANCES (UNLESS SPECIFIED)		DIMENSION STYLE MM ONLY		51338-xx74		MODEL NO.	
	10 UNDER	±---	DRAWN BY M. NINOMI	DATE 2004/03/17	SCALE ---	DESIGN UNITS METRIC	THIRD ANGLE PROJECTION	
	10 OVER 30 UNDER	±---	CHECKED BY K. TOJO	DATE 2004/03/17	TITLE 0.4 B-TO-B CONN. REC HSG ASSY(HGT=1.5) EMBSTP PKG -LEAD FREE-			
	30 OVER	±---	APPROVED BY M. SASAO	DATE 2004/03/17	MOLEX INCORPORATED			
	ANGULAR	±---	MATERIAL NO. SEE CHART		DOCUMENT NO. SD-51338-004		SHEET NO. 1 OF 4	
	DRAFT WHERE APPLICABLE MUST REMAIN WITHIN DIMENSIONS		SIZE A3		THIS DRAWING CONTAINS INFORMATION THAT IS PROPRIETARY TO MOLEX INCORPORATED AND SHOULD NOT BE USED WITHOUT WRITTEN PERMISSION			

10 9 8 7 6 5 4 3 2 1

F

E

D

C

B

A

F

E

D

C

B

A

引き出し方向
PULL OUT
DIRECTION

トップテープ
TOP TAPE

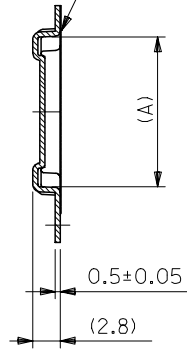

SECT:Y-Y

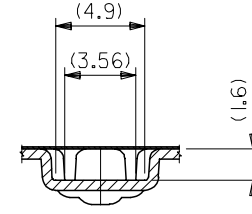
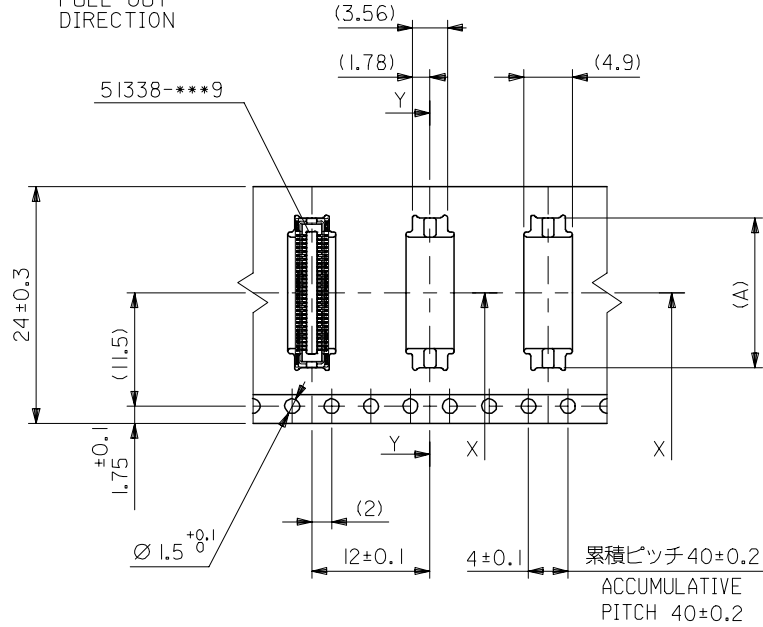

SECT:X-X

24mm幅キャリアテープ
24mm WIDTH CARRIER TAPE

24	29.4	25.4	15.26	51338-0674	60		
			13.26	51338-0574	50		
			11.26	51338-0474	40		
			10.06	51338-3474	34		
			9.26	51338-0374	30		
			8.46	51338-2674	26		
			8.06	51338-2474	24		
			7.66	51338-2274	22		
			7.26	51338-0274	20		
5.66	51338-9974	12					
キャリアテープ幅 CARRIER TAPE WIDTH			C	B	(A)	MATERIAL NO.	極数 CKT.

REVISED EC NO: J2006-0826 DRWN: TAKEMOTO 2005/09/30 CHKD: TANAKA 2005/09/30 APPR: NUKITA 2005/09/30	GENERAL TOLERANCES (UNLESS SPECIFIED)		DIMENSION STYLE MM ONLY		SCALE ---		DESIGN UNITS METRIC		THIRD ANGLE PROJECTION	
	10 UNDER	±---	DRAWN BY M. NINOMI	DATE 2004/03/17	TITLE 0.4 B-TO-B CONN. REC HSG ASSY(HGT=1.5) EMBSTP PKG -LEAD FREE-					
	10 OVER 30 UNDER	±---	CHECKED BY K. TOJO	DATE 2004/03/17	APPROVED BY M. SASAO 2004/03/17					
	30 OVER	±---	APPROVED BY M. SASAO 2004/03/17		MATERIAL NO. SEE CHART		DOCUMENT NO. SD-51338-004		SHEET NO. 2 OF 4	
	ANGULAR	±---	DRAFT WHERE APPLICABLE MUST REMAIN WITHIN DIMENSIONS							

10 9 8 7 6 5 4 3 2 1

F

E

D

C

B

A

F

E

D

C

B

A

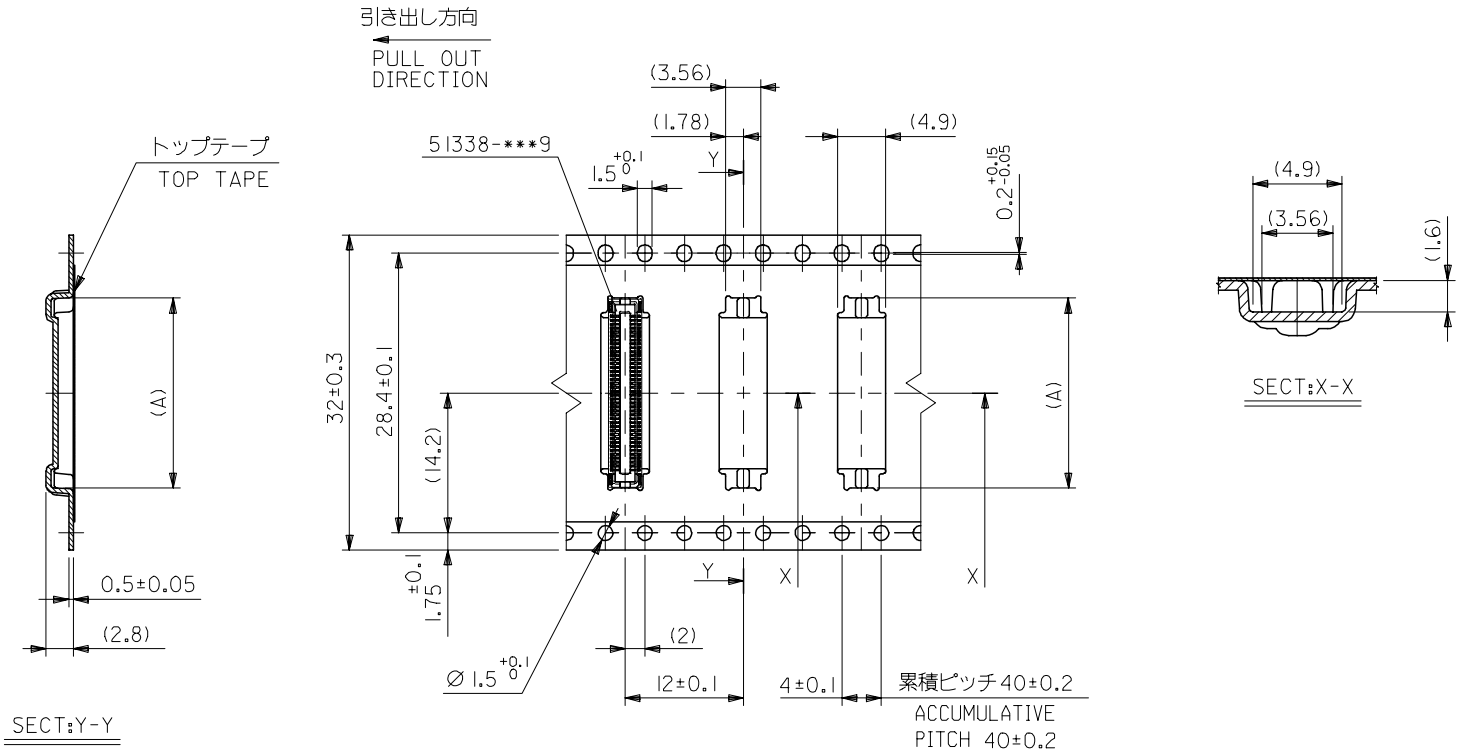

32mm幅キャリアテープ
32mm WIDTH CARRIER TAPE

32	37.4	33.4	21.26	51338-0974	90
			19.26	51338-0874	80
			17.26	51338-0774	70
キャリアテープ幅 CARRIER TAPE WIDTH	C	B	(A)	MATERIAL NO.	極数 CKT.

REVISED EC NO: J2006-0826 DRW: TAKEMOTO 2005/09/30 CHK: TANAKA 2005/09/30 APPR: NUKITA 2005/09/30	GENERAL TOLERANCES (UNLESS SPECIFIED)		DIMENSION STYLE MM ONLY		SCALE ---		DESIGN UNITS METRIC		THIRD ANGLE PROJECTION	
	10 UNDER	±---	DRAWN BY M. NINOMI	DATE 2004/03/17	TITLE 0.4 B-TO-B CONN. REC HSG ASSY(HGT=1.5) EMBSTP PKG -LEAD FREE-					
	10 OVER 30 UNDER	±---	CHECKED BY K. TOJO	DATE 2004/03/17	MOLEX INCORPORATED					
	30 OVER	±---	APPROVED BY M. SASAO	DATE 2004/03/17	MATERIAL NO. SEE CHART		DOCUMENT NO. SD-51338-004		SHEET NO. 3 OF 4	
	ANGULAR ±---		DRAFT WHERE APPLICABLE MUST REMAIN WITHIN DIMENSIONS		THIS DRAWING CONTAINS INFORMATION THAT IS PROPRIETARY TO MOLEX INCORPORATED AND SHOULD NOT BE USED WITHOUT WRITTEN PERMISSION					

9

8

7

6

5

4

3

2

10 9 8 7 6 5 4 3 2 1

F

E

D

C

B

A

F

E

D

C

B

A

引き出し方向
PULL OUT
DIRECTION

トップテープ
TOP TAPE

51338-***9

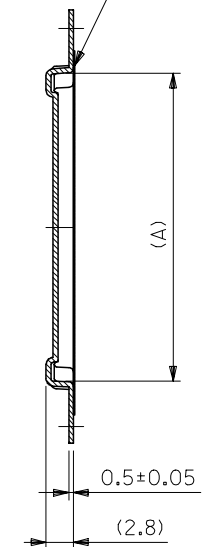

SECT:Y-Y

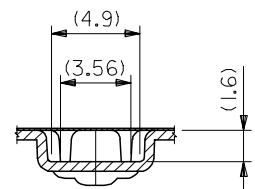
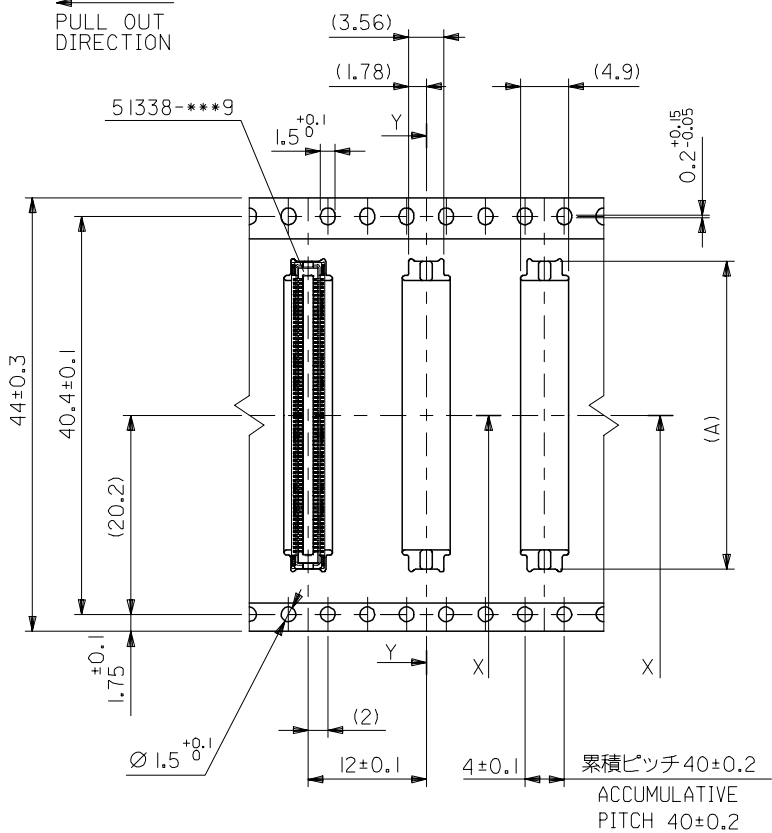

SECT:X-X

44mm幅キャリアテープ
44mm WIDTH CARRIER TAPE

44	49.4	45.4	27.26	51338-1274	120
			23.26	51338-1074	100
キャリアテープ幅 CARRIER TAPE WIDTH	C	B	(A)	MATERIAL NO.	極数 CKT.

51338-***74 MODEL NO.

REVISED EC NO: J2006-0826 DRWN: TAKEMOTO CHKD: 2005/09/30 APPR: NUKITA 2005/09/30	GENERAL TOLERANCES (UNLESS SPECIFIED)		DIMENSION STYLE MM ONLY		SCALE ---	DESIGN UNITS METRIC	THIRD ANGLE PROJECTION
	10 UNDER	±---	DRAWN BY M. NINOMI	DATE 2004/03/17	TITLE 0.4 B-TO-B CONN. REC HSG ASSY(HGT=1.5) EMBSTP PKG -LEAD FREE-		
	10 OVER 30 UNDER	±---	CHECKED BY K. TOJO	DATE 2004/03/17	MOLEX INCORPORATED		
	30 OVER	±---	APPROVED BY M. SASAO	DATE 2004/03/17	DOCUMENT NO. SD-51338-004		
	ANGULAR	±---	MATERIAL NO. SEE CHART		SHEET NO. 4 OF 4		
DRAFT WHERE APPLICABLE MUST REMAIN WITHIN DIMENSIONS		THIS DRAWING CONTAINS INFORMATION THAT IS PROPRIETARY TO MOLEX INCORPORATED AND SHOULD NOT BE USED WITHOUT WRITTEN PERMISSION					