

RoHS Compliant Product

Description

The SPWLM386D is a power amplifier, designed for use in low voltage consumer applications. The gain is internally set to 20 to keep external part count low, but the addition of an external resistor and capacitor between pin 1 and pin 8 will increase the gain to any value up from 20 to 200. The input are ground referenced while the output automatically biases to one-half the supply voltage. The quiescent power drain is only 24 milliwatts when operating from a 6 voltage supply, marking the SPWLM386D ideal for battery operation.

Features

- * Ground Referenced Input
- * Low Quiescent Current Drain: 4mA
- * Wide Supply Voltage Range: 4V~12V
- * Voltage Gains: 20~200
- * Low Distortion: 0.2% ($A_v=20$, $V_s=6V$, $R_L=8\Omega$, $P_o=125mW$, $f=1\text{ kHz}$)
- * Self-Centering Output Quiescent Voltage
- * Battery Operation
- * Minimum External Parts

Applications

- * Line Drivers
- * Power Converters
- * Small Servo Drivers
- * Intercoms
- * Ultrasonic Drivers
- * AM-FM Radio Amplifiers
- * Portable Tape Player Amplifiers
- * TV sound Systems

DIP-8

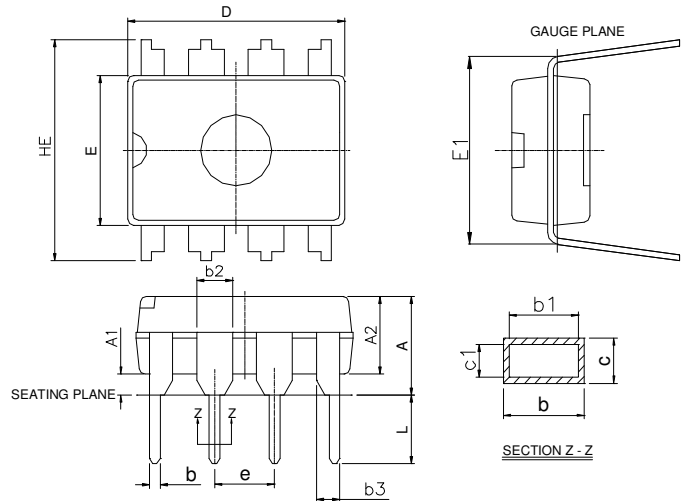

REF.	Millimeter		REF.	Millimeter	
	Min.	Max.		Min.	Max.
A	-	0.5334	c1	0.203	0.279
A1	0.381	-	D	9.017	10.16
A2	2.921	4.953	E	6.096	7.112
b	0.356	0.559	E1	7.620	8.255
b1	0.356	0.508	e	2.540 BSC	
b2	1.143	1.778	HE	-	10.92
b3	0.762	1.143	L	2.921	3.810
c	0.203	0.356			

Marking :

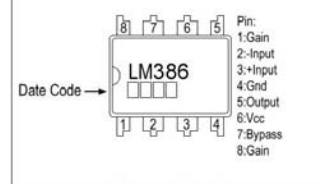

Equivalent Schematic and Connection Diagram

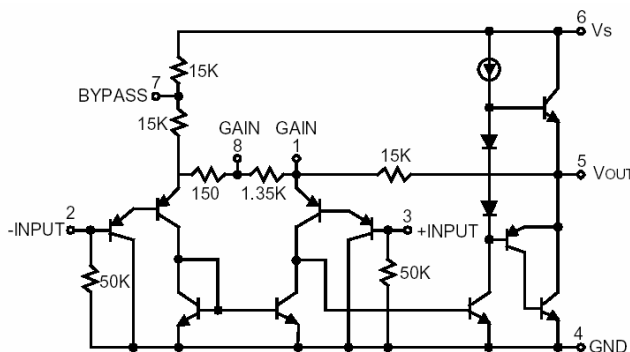

Absolute Maximum Ratings (Note 2)

Parameter	Symbol	Value	Unit
Supply Voltage	VCC	15	V
Power Dissipation	Pd	1.25	W
Input Voltage	Vi	-0.4 ~ +0.4	V
Operating Temperature	Topr	0 ~ 70	°C
Storage Temperature	Tstg	-65 ~ 150	°C
Junction Temperature	Tj	150	°C

Electrical Characteristics (TA=25°C Note1, 2)

Parameter	Symbol	Test Conditions	Min	Typ.	Max.	Unit
Operating Supply Voltage	VS		4	-	12	V
Quiescent Current	IQ	VS=6V, VIN=0	-	4	8	mA
Output Power	PO	VS=6V, RL=8Ω, THD=10% VS=9V, RL=8Ω, THD=10%	230 480	-	-	mW
Voltage Gain	Gv	VS=6V, f=1kHz 10μF form Pin1 to Pin8	-	26 46	-	dB
Bandwidth	BW	VS=6V, Pin1 to Pin8 open	-	300	-	kHz
Total Harmonic Distortion	THD	PO=125mW, VS=6V, f=1kHz RL=8Ω, Pin1 to Pin8 open	-	0.2	-	%
Power Supply Rejection Ration	PSRR	VS=6V, f=1kHz, CBYPASS=10μF Pin1 and Pin8 open, Referred to output	-	50	-	dB
Input Resistance	RIN		-	50	-	kΩ
Input Bias Current	IBIAS	VS=6V, Pin2 to Pin3 open	-	250	-	nA

Note1: All voltages are measured with respect to the ground pin, unless otherwise specified.

Note2: Absolute Maximum Ratings indicate limits beyond which damage to the device may occur. Operating Ratings indicate conditions for which the device is functional, but do not guarantee specific performance limits. Electrical Characteristics state DC and AC electrical specifications under particular test conditions which guarantee specific performance limits. This assumes that the device is within the Operating Ratings.

Specifications are not guaranteed for parameters where no limit is given, however, the typical value is a good indication of device performance.

Note3: For operation in ambient temperatures above 25°C, the device must be derated based on a 150°C maximum junction temperature and 1) a thermal resistance of 107°C/W, junction to ambient for the dual-in-line package and 2) a thermal resistance of 170 °C/W for the small outline package.

Application Hints

Gina Control

To make the SPWLM386D a more versatile amplifier, two pins (1 and 8) are provided for gain control. With pins 1 and 8 open the 1.35kΩ resistor sets the gain at 20 (26dB). If a capacitor is put from pin 1 to 8, bypassing the 1.35kΩ resistor, the gain will go up to 200 (46dB). If a resistor is placed in series with the capacitor the gain can be set to any value from 20 to 200. Gain control can also be done by capacitively coupling a resistor (or FET) from pin 1 to ground.

Additional external components can be placed in parallel with the internal feedback resistors to tailor the gain and frequency response for individual applications. For example we can compensate poor speaker bass response by frequency shaping the feedback path. This is done with a series RC from pin 1 to 5 (paralleling the internal 15kΩ resistor). For 6 dB effective bass boost: R=15kΩ, the lowest value for good stable operation in R=10kΩ, if pin 8 is open, If pins 1 and 8 are bypassed then R as low as 2kΩ can be used. This restriction is because the amplifier is only compensated for closed-loop gains greater than 9.

Input Biasing

The schematic show that both input are biased to ground with a 50kΩ resistor. The base current of the input transistors is about 250nA, so the inputs are at about 12.5mW when left open. If the dc source resistance driving the SPWLM386D is higher than 250kΩ it will contribute very little additional offset (about 2.5mW at the input, 50mW at the output). If the dc source resistance is less than 10k, then shorting the unused input to ground will keep the offset low (about 2.5mW at the input, 50mW at the output). For dc source resistance between these values we can eliminate excess offset by putting a resistor from the unused input to ground, equal in value to the dc source resistance. Of course all offset problems are eliminated if the input is capacitively coupled.

When using the SPWLM386D with higher gains (bypassing the 1.35kΩ resistor between pin1 and 8) it is necessary to bypass the unused input, preventing degradation of gain and possible instabilities. This is done with a 0.1μF capacitor or a short to ground depending on the dc source resistance on the driven input.

Typical Performance Characteristics

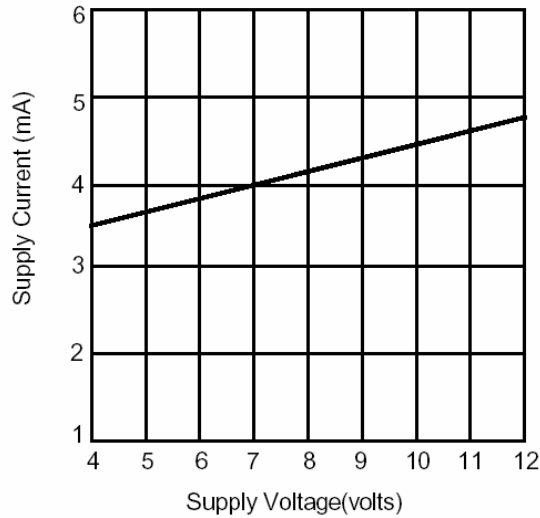

Fig 1. Quiescent Supply Current vs. Supply Voltage

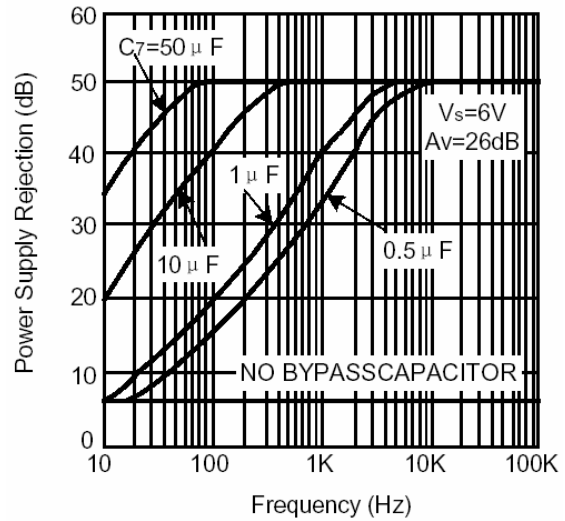

Fig 2. Power Supply Rejection Ratio (Referred to the output) vs. Frequency

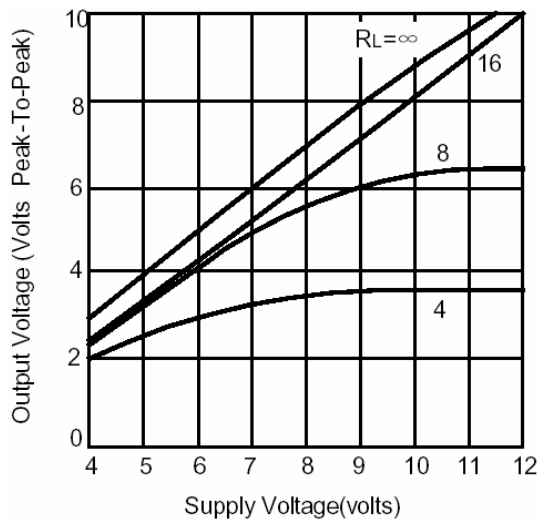

Fig 3. Peak-to-Peak Voltage Swing vs. Supply Voltage

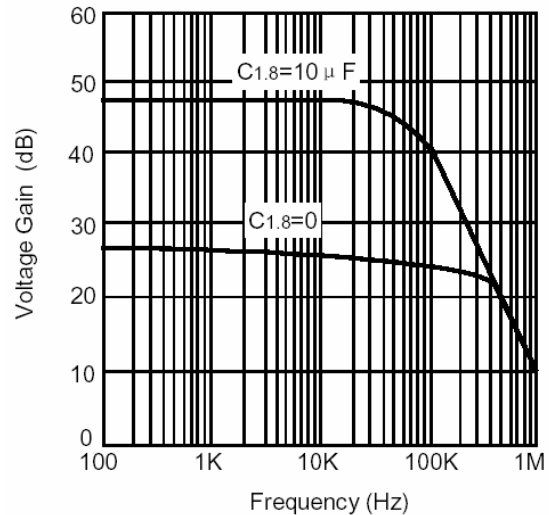

Fig 4. Voltage Gain vs. Frequency

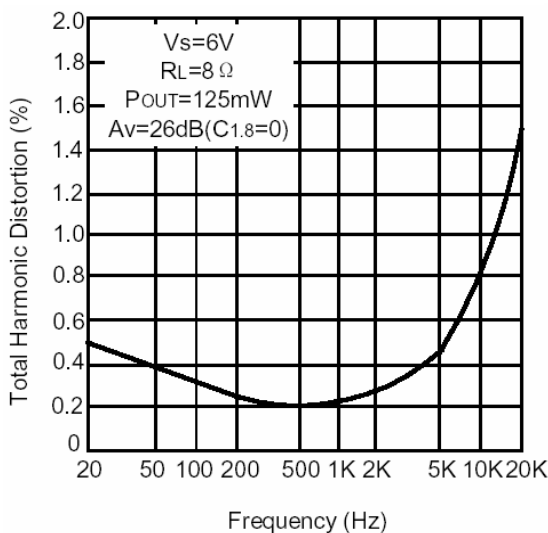

Fig 5. Distortion vs. Frequency

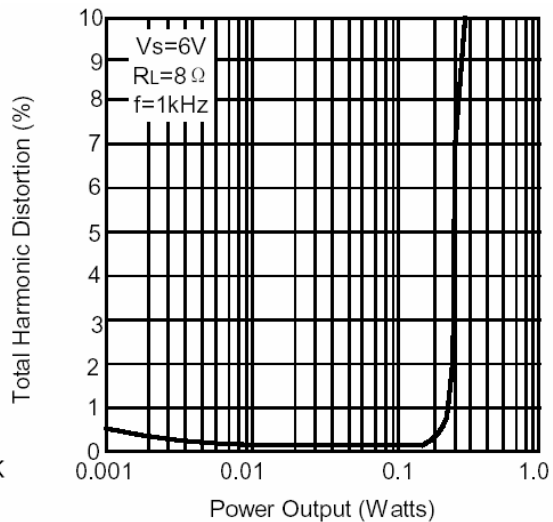

Fig 6. Distortion vs. Output Power

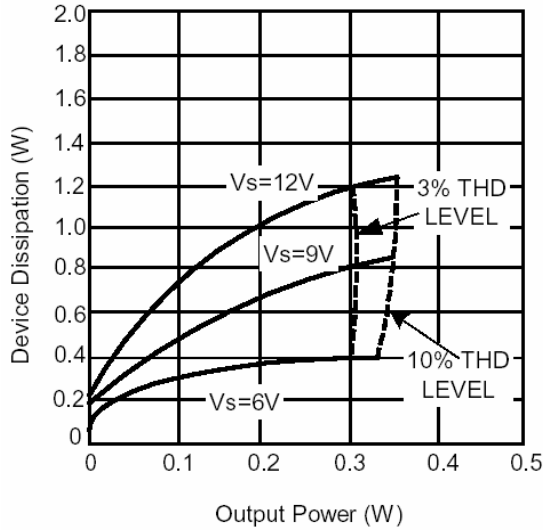

Fig 7. Device Dissipation vs. Output Power -4Ω Load

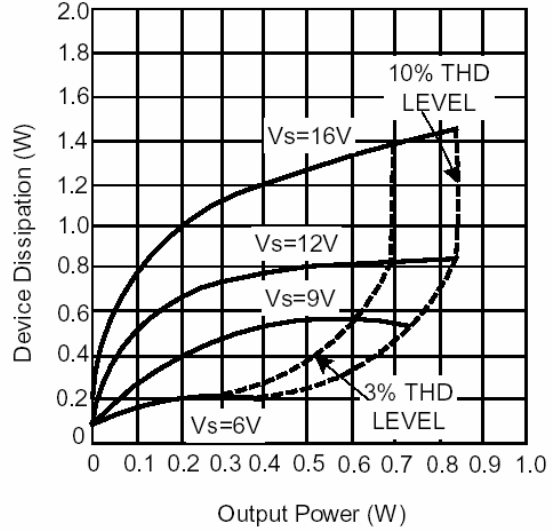

Fig 8. Device Dissipation vs. Output Power -8Ω Load

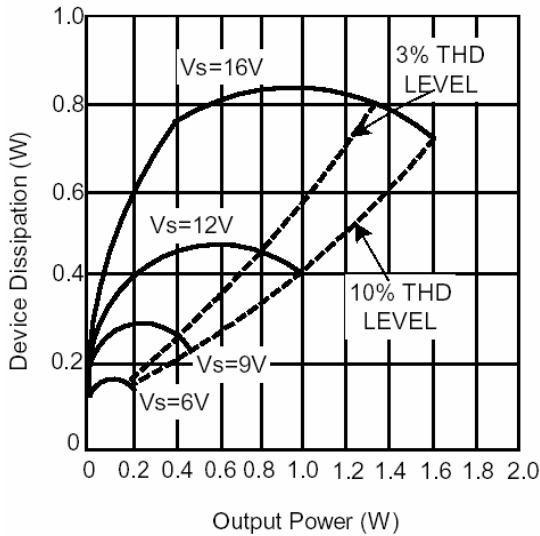

Fig 9. Device Dissipation -16

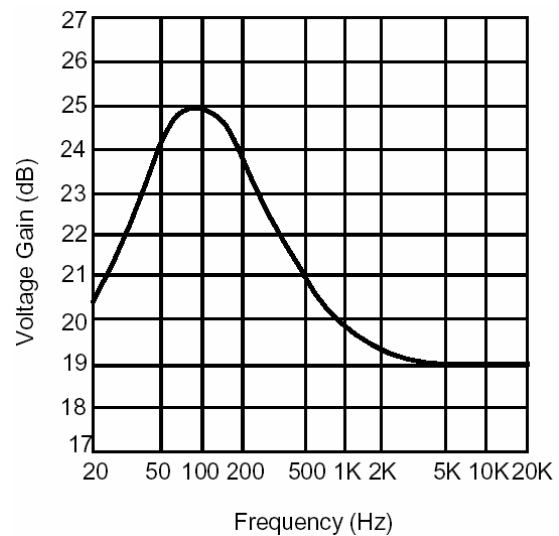
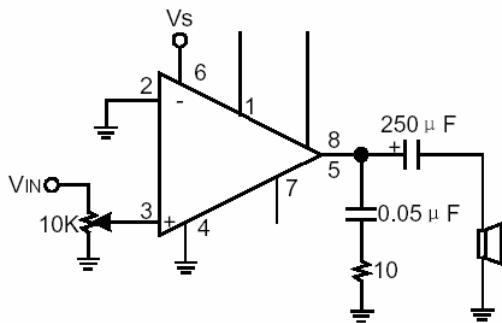
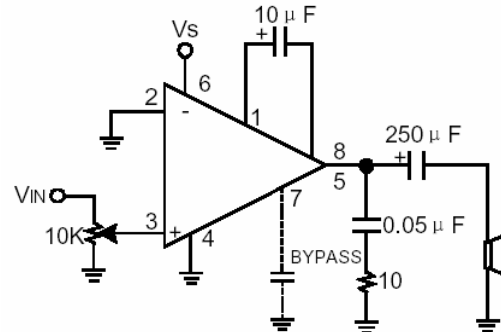

Fig 10. Frequency Response with Bass Boost

Typical Applications



**Amplifier with Gain=20
Minimum Parts**



Amplifier with Gain=200

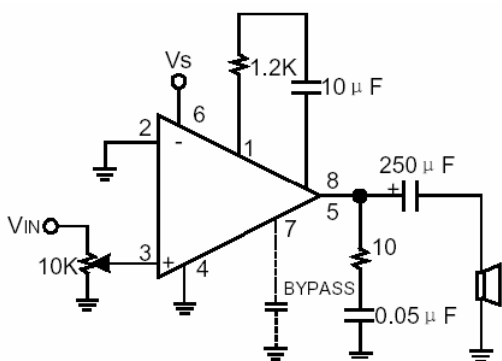

Amplifier with Gain=50

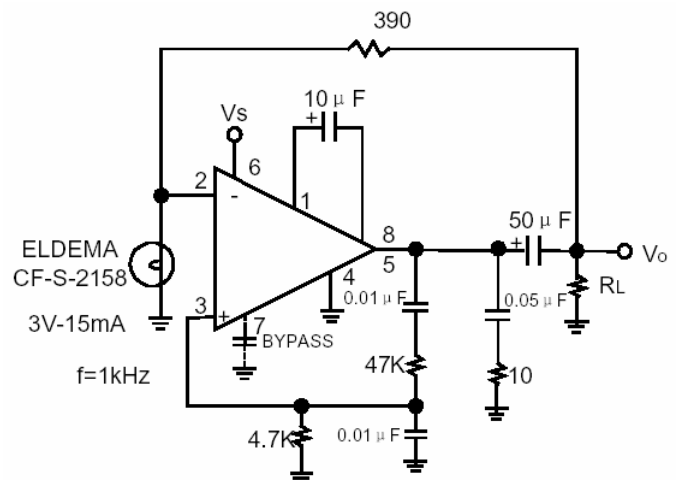

Low Distortion Power Wienbridge Oscillator

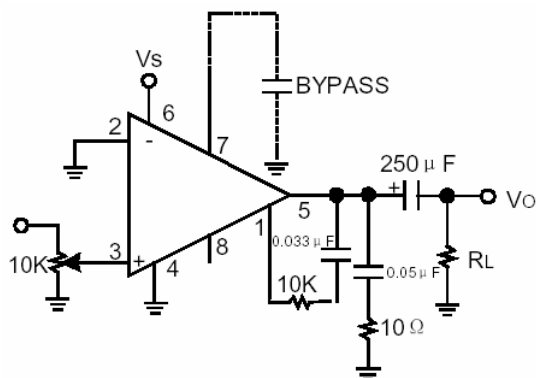

Amplifier with Bass Boost

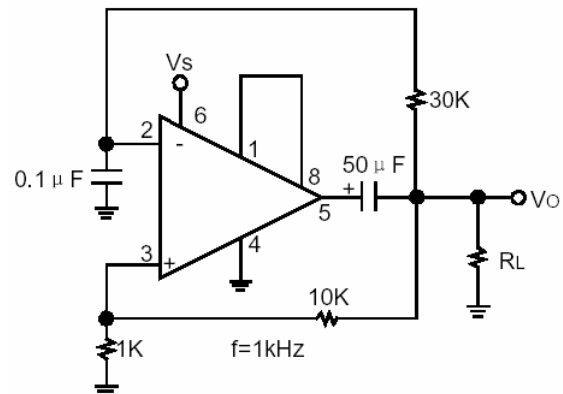

Square Wave Oscillator

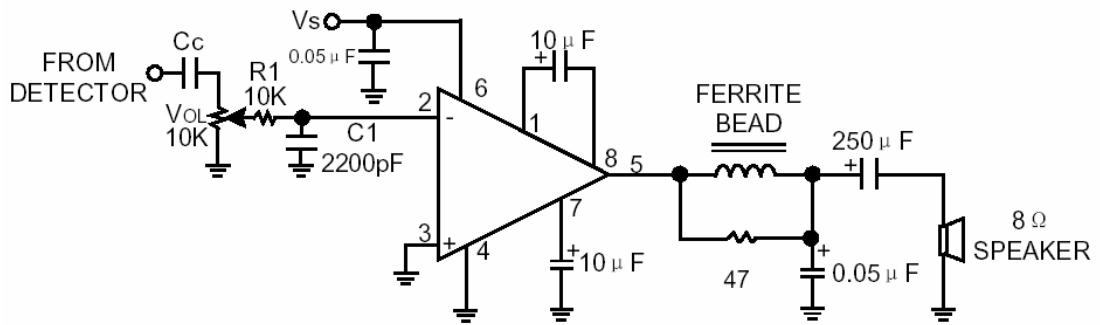

AM Radio Power Amplifier

- Note4: Twist supply lead and supply ground very tightly.
- Note5: Twist speaker lead and ground very tightly.
- Note6: Ferrite bead in Ferroxcube K5-001-001/3B with 3 turns of wire.
- Note7: R1C1 band limits input signals.
- Note8: All components must be spaced very closely to IC.