



Technical Data Sheet

Luminosity Full Color LED

61-13/S3GHBHC-B04/ET

Features

- Super-luminosity chip LED.
- White SMT package.
- Built in Red, Green, and Blue chips.
- Lead frame package with individual 6 pins.
- Wide viewing angle.
- Soldering methods: IR reflow soldering.
- Pb-free.
- ESD protection.
- The product itself will remain within RoHS compliant version.



Descriptions

- Due to the package design, 61-13 has wide viewing angle , low power consumption and adjusting each color is possible thanks to serial connection by 6 terminal connection (Individual driving by each terminal) in case of using several number of LED. And makes it ideal for light pipe application.

Applications

- Amusement equipment.
- Information boards.
- Flashlight for digital camera of cellular phone.

Device Selection Guide

Chip			Lens Color
Type	Material	Emitted Color	
S3	AlGaInP	Reddish Orange	Water Clear
GH	InGaN	Brilliant Green	
BH	InGaN	Blue	

Package Outline Dimensions

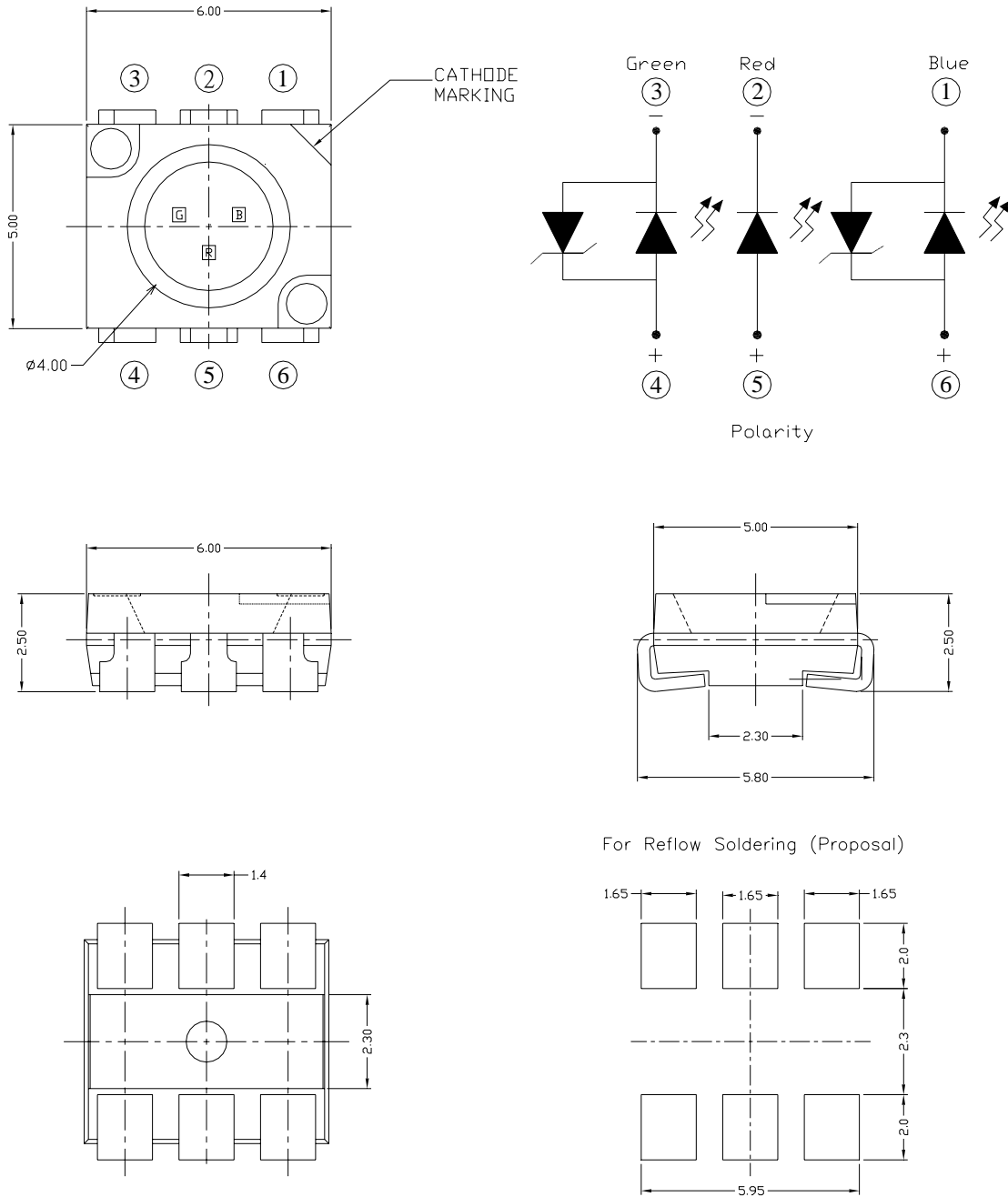

Notes: 1.All dimensions are in millimeters. 2.Tolerances unspecified are ± 0.1 mm.

Absolute Maximum Ratings (Ta=25°C)

Parameter	Symbol	Rating	Unit
Reverse Voltage	V _R	5	V
Forward Current	I _F	R6	50
		GH	25
		BH	25
Power Dissipation	P _d	R6	120
		GH	110
		BH	110
Peak Forward Current(Duty 1/10 @ 1KHz)	I _{FP}	R6	100
		GH	100
		BH	100
Electrostatic Discharge	ESD	R6	2000
		GH	2000
		BH	2000
Operating Temperature	T _{opr}	-40 ~ +85	°C
Storage Temperature	T _{stg}	-40~ +90	°C
Soldering Temperature	T _{sol}	Reflow Soldering : 260 °C for 10 sec. Hand Soldering : 350 °C for 3 sec.	

Electro-Optical Characteristics (Ta=25°C)

Parameter	Symbol	Min.	Typ.	Max.	Unit	Condition	
Luminous Intensity	I _v	S3	180	-----	360	mcd	I _F =20mA
		GH	450	-----	900		I _F =20mA
		BH	112	-----	225		I _F =20mA
Viewing Angle	2θ _{1/2}	-----	120	-----	deg	I _F =20mA	
Peak Wavelength	λ _p	S3	-----	632	-----	nm	I _F =20mA
		GH	-----	518	-----		
		BH	-----	468	-----		
Dominant Wavelength	λ _d	S3	613.5	-----	618.5	nm	I _F =20mA
		GH	520.0	-----	525.0		
		BH	465.0	-----	470.0		
Spectrum Radiation Bandwidth	Δλ	S3	-----	20	-----	nm	I _F =20mA
		GH	-----	35	-----		
		BH	-----	35	-----		
Forward Voltage	V _F	S3	1.8	----	2.4	V	I _F =20mA
		GH	3.0	----	3.6		
		BH	3.0	---	3.6		

Notes:

1. Tolerance of Luminous Intensity ±11%
2. Tolerance of Dominant Wavelength ±1 nm
3. Tolerance of Dominant Forward Voltage ±0.1V

Bin Range Of Luminous Intensity

Symbol		Bin Code	Min.	Max.	Unit	Condition
I _v	S3	S1	180	225	mcd	I _F =20mA
		S2	225	285		
		T1	285	360		
	GH	U1	450	565		
		U2	565	715		
		V1	715	900		
	BH	R1	112	140		
		R2	140	180		
		S1	180	225		

Bin Range Of Dominant Wavelength

Symbol		Bin Code	Min.	Max.	Unit	Condition
λ _d	S3	----	613.5	618.5	nm	I _F =20mA
	GH	----	520.0	525.0		
	BH	----	465.0	470.0		

Notes:

1. Tolerance of Luminous Intensity ±11%
2. Tolerance of Dominant Wavelength ±1 nm

Bin Range Of Forward Voltage

Symbol		Bin Code	Min.	Max.	Unit	Condition
VF	S3	S1	1.8	2.0	V	I _F =20mA
		S2	2.0	2.2		
		S3	2.2	2.4		
	GH	G1	3.0	3.2		
		G2	3.2	3.4		
		G3	3.4	3.6		
	BH	B1	3.0	3.2		
		B2	3.2	3.4		
		B3	3.4	3.6		

Notes:

1. Tolerance of Forward Voltage ± 0.1 V

Typical Electro-Optical Characteristics Curves (BH)

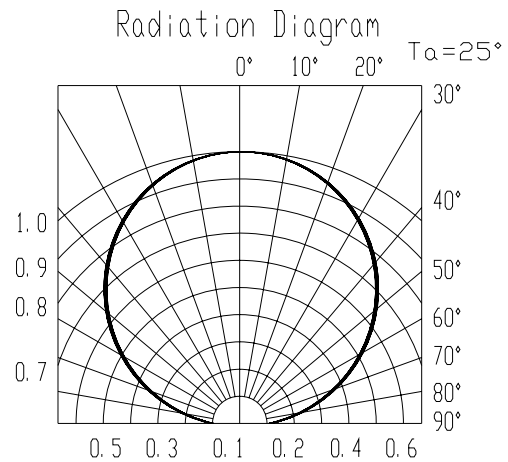
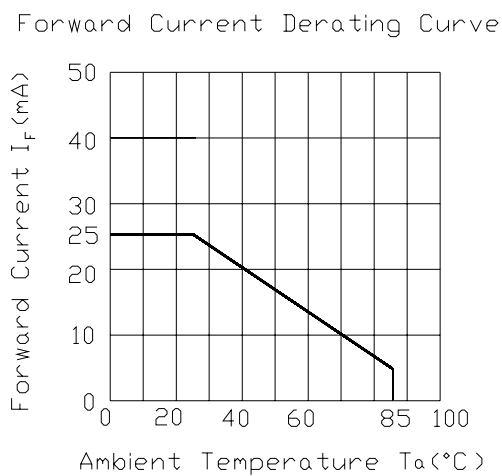
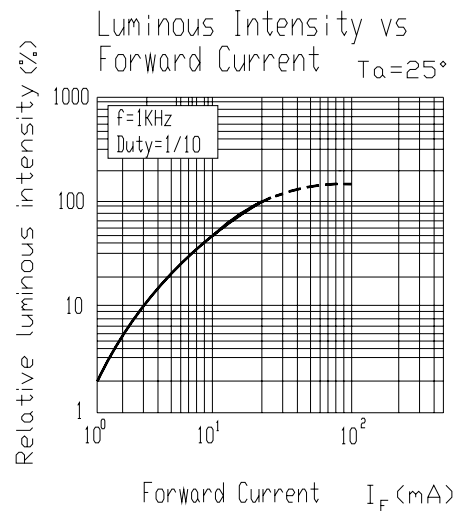
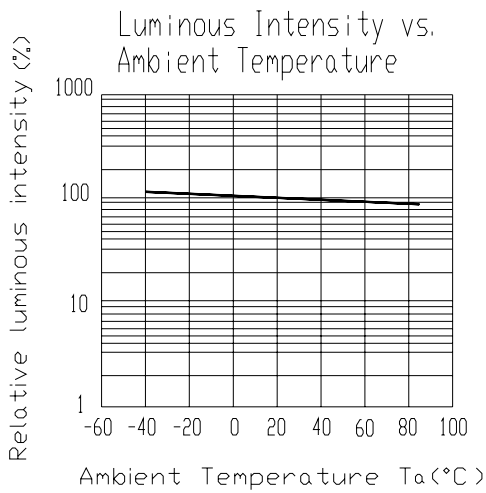
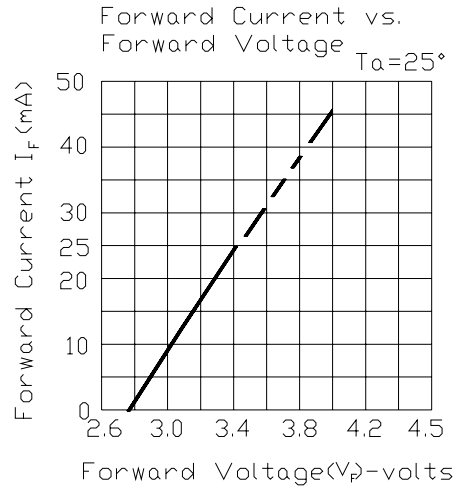
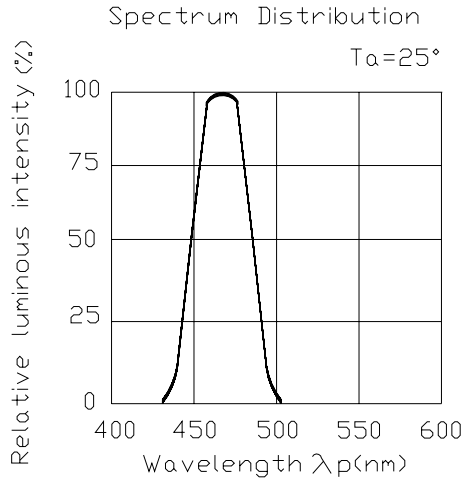

Typical Electro-Optical Characteristics Curves (GH)

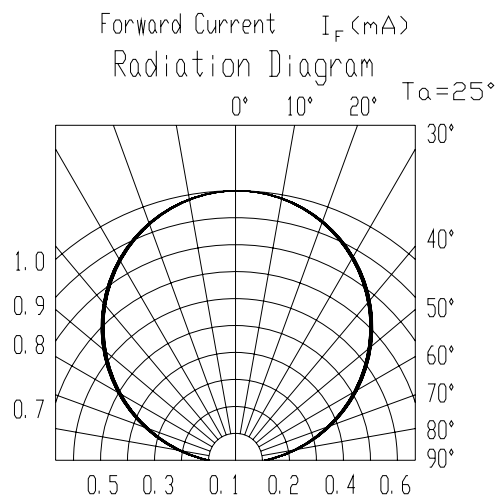
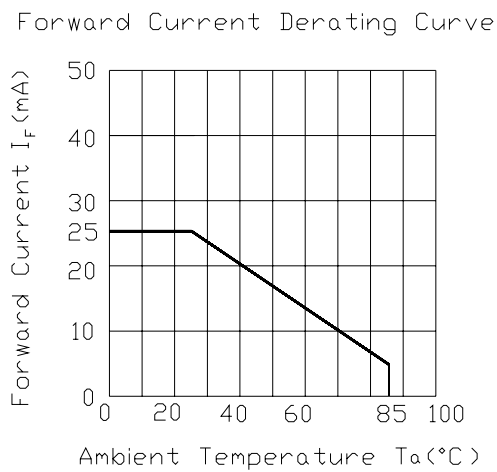
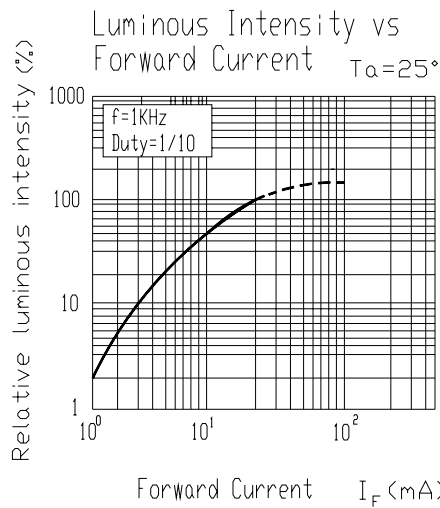
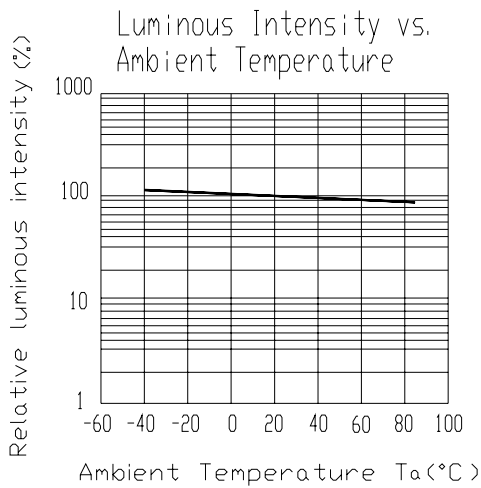
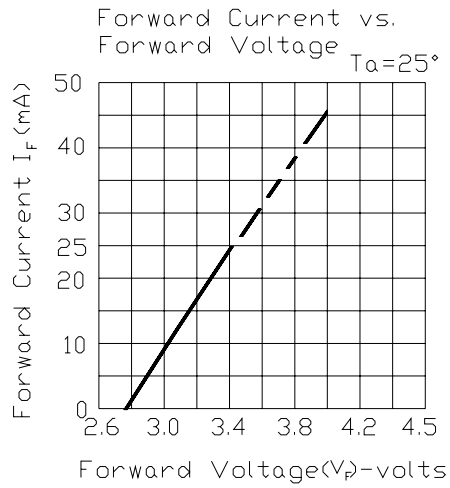
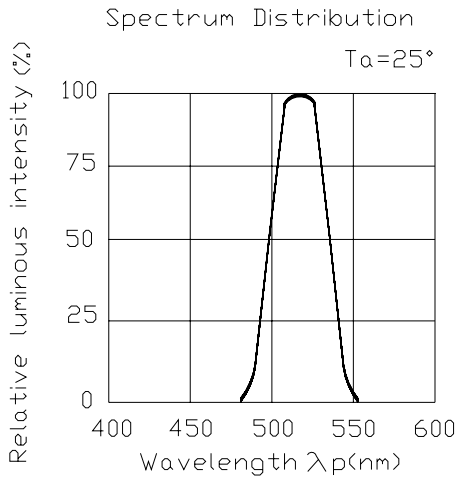

Typical Electro-Optical Characteristics Curves (S3)

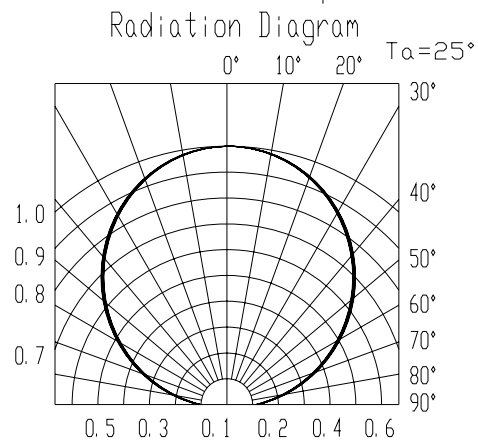
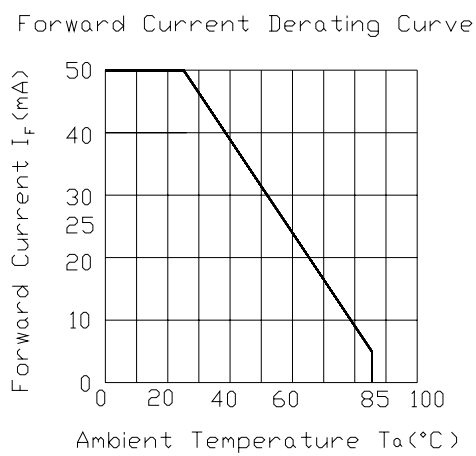
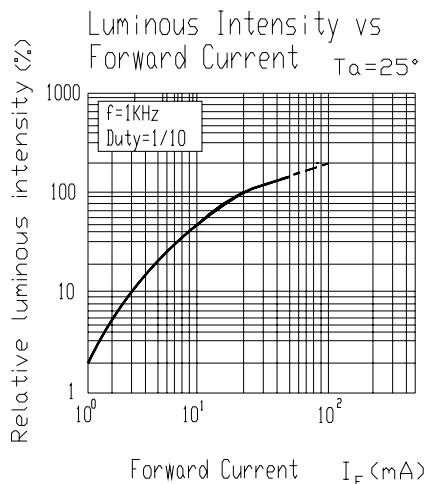
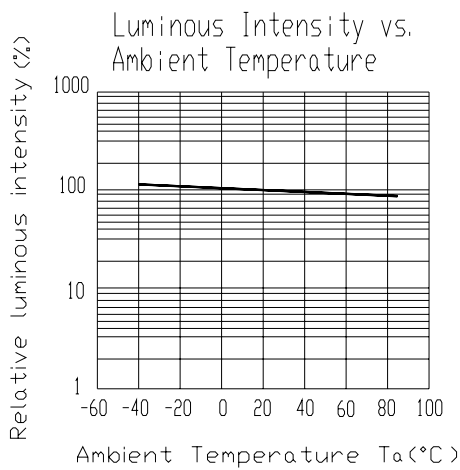
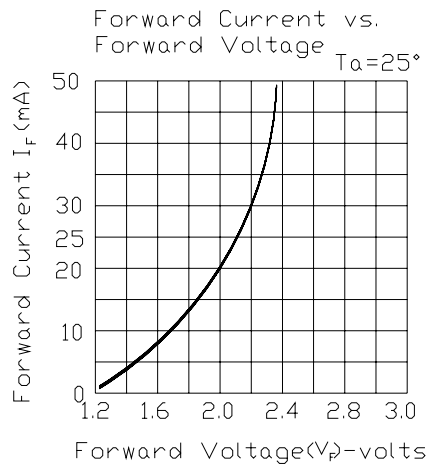
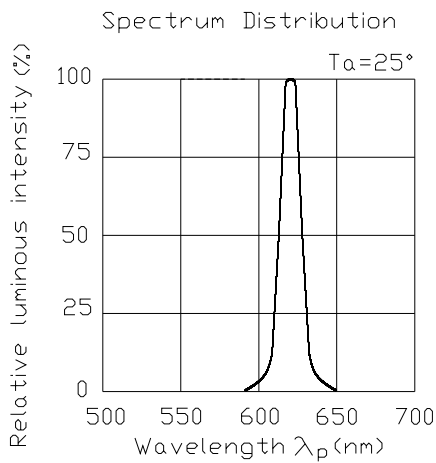

Label explanation

CAT: Luminous Intensity Rank

HUE: Dom. Wavelength Rank

REF: Forward Voltage Rank

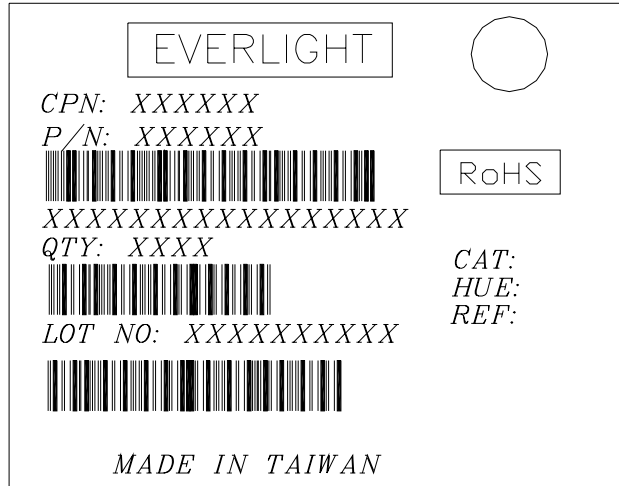

Reel Dimensions

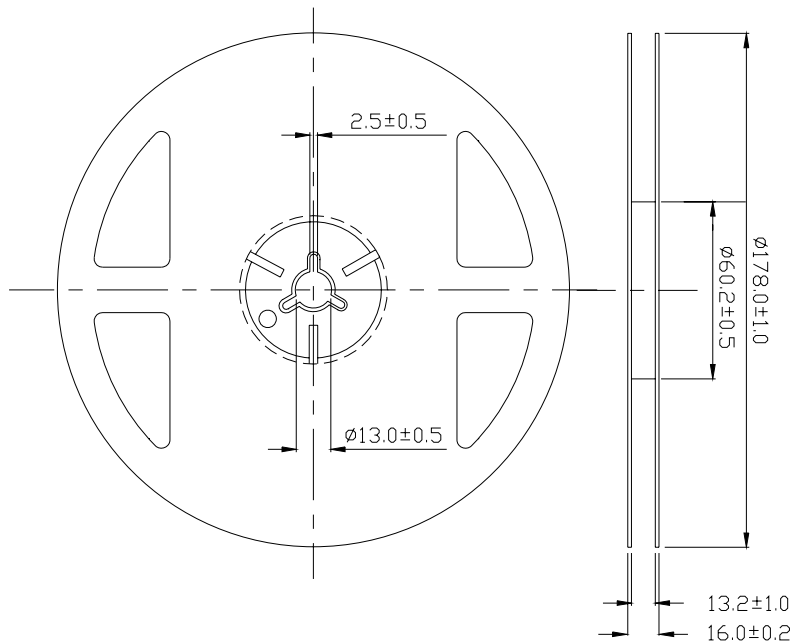

Note: The tolerances unless mentioned is $\pm 0.1\text{mm}$,Unit = mm

Loaded quantity per reel 800 PCS/reel

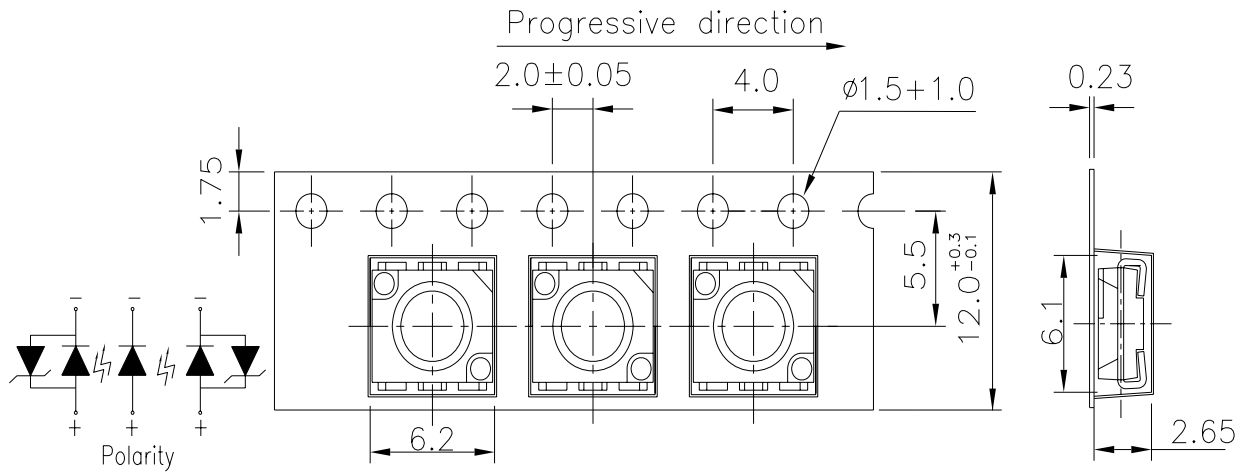

Note: The tolerances unless mentioned is ± 0.1 mm ,Unit = mm

Moisture Resistant Packaging

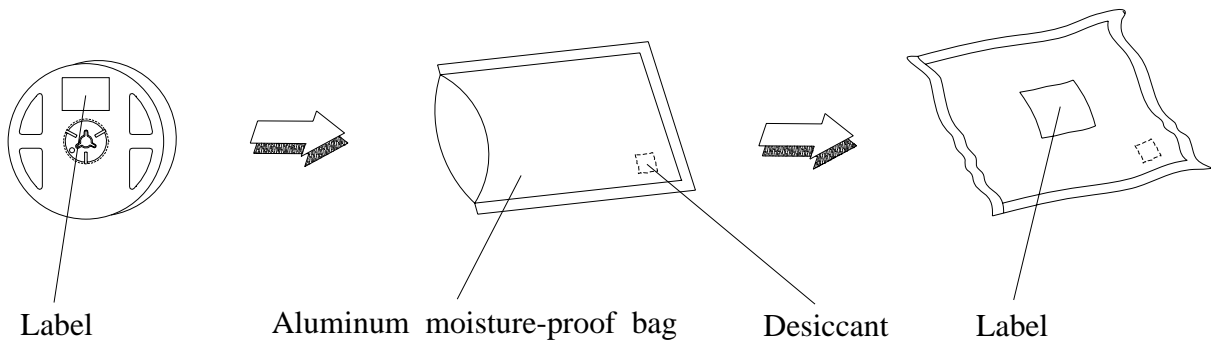

Reliability Test Items And Conditions

The reliability of products shall be satisfied with items listed below.

Confidence level : 90%

LTPD : 10%

No.	Items	Test Condition	Test Hours/Cycles	Sample Size	Ac/Re
1	Reflow Soldering	Temp. : 260°C ±5°C Min. 5sec.	6 Min.	22 PCS.	0/1
2	Temperature Cycle	H : +100°C 15min ∫ 5 min L : -40°C 15min	300 Cycles	22 PCS.	0/1
3	Thermal Shock	H : +100°C 5min ∫ 10 sec L : -10°C 5min	300 Cycles	22 PCS.	0/1
4	High Temperature Storage	Temp. : 100°C	1000 Hrs.	22 PCS.	0/1
5	Low Temperature Storage	Temp. : -40°C	1000 Hrs.	22 PCS.	0/1
6	DC Operating Life	IF = 20 mA	1000 Hrs.	22 PCS.	0/1
7	High Temperature / High Humidity	85°C/ 85%RH	1000 Hrs.	22 PCS.	0/1

* For each die

Precautions For Use

1. Over-current-proof

Customer must apply resistors for protection, otherwise slight voltage shift will cause big current change (Burn out will happen).

2. Storage

- 2.1 Do not open moisture proof bag before the products are ready to use.
- 2.2 Before opening the package: The LEDs should be kept at 30°C or less and 90%RH or less.
- 2.3 After opening the package: The LED's floor life is 1 year under 30°C or less and 60% RH or less.

If unused LEDs remain, it should be stored in moisture proof packages.

- 2.4 If the moisture absorbent material (silica gel) has faded away or the LEDs have exceeded the storage time, baking treatment should be performed using the following conditions.

Baking treatment : 60±5°C for 24 hours.

3. Soldering Condition

3.1 Pb-free solder temperature profile

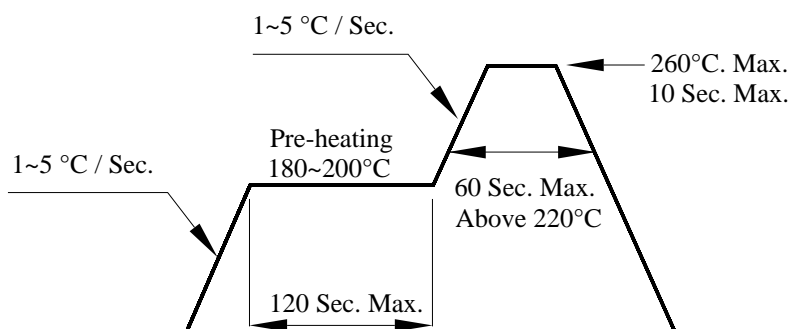

- 3.2 Reflow soldering should not be done more than two times.
- 3.3 When soldering, do not put stress on the LEDs during heating.
- 3.4 After soldering, do not warp the circuit board.

4. Soldering Iron

Each terminal is to go to the tip of soldering iron temperature less than 350°C for 3 seconds within once in less than the soldering iron capacity 25W. Leave two seconds and more intervals, and do soldering of each terminal. Be careful because the damage of the product is often started at the time of the hand solder.

5. Repairing

Repair should not be done after the LEDs have been soldered. When repairing is unavoidable, a double-head soldering iron should be used (as below figure). It should be confirmed beforehand whether the characteristics of the LEDs will or will not be damaged by repairing.

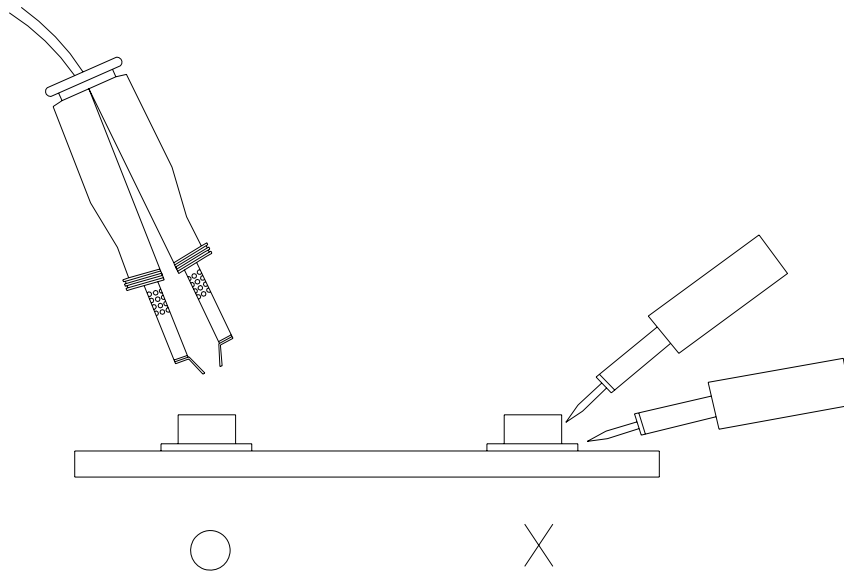

EVERLIGHT ELECTRONICS CO., LTD.
Office: No 25, Lane 76, Sec 3, Chung Yang Rd,
Tucheng, Taipei 236, Taiwan, R.O.C

Tel: 886-2-2267-2000, 2267-9936
Fax: 886-2267-6244, 2267-6189, 2267-6306
<http://www.everlight.com>