

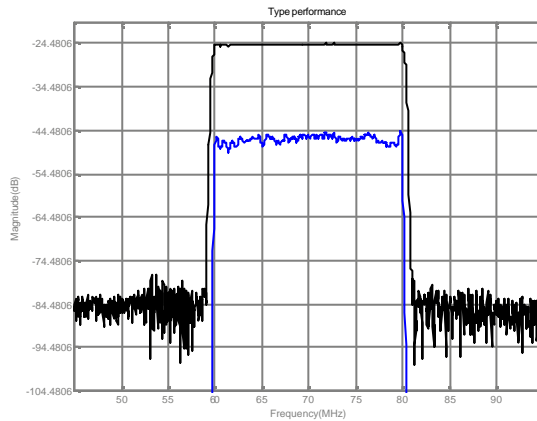

LBN07075 SAW Filter Electrical Characteristic

<i>Specifications</i>				
Parameter	Unit	Minimum	Typical	Maximum
Center Frequency	MHz	69.90	70	70.10
Insertion Loss	dB	-	24.5	27
1 dB Bandwidth	MHz	19.90	20.14	20.3
3 dB Bandwidth	MHz	20.30	20.45	20.7
40 dB Bandwidth	MHz	21.3	21.62	21.7
50 dB Bandwidth	MHz	-	21.75	-
Passband Variation	dB	-	0.4	1.0
Group Delay Variation	nsec	-	18	80
Absolute Delay	usec	-	2.55	3.50
Ultimate Rejection	dB	50	55	-
Substrate Material		128 LiNbO3		
Ambient Temperature	°C	25		
Center Frequency		DIP3512 (35.0x12.7x5.2mm ³)		

Typical Performance



Package Outline

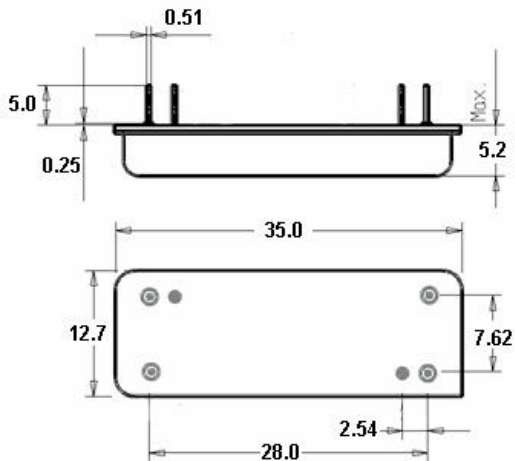

Matching Configuration

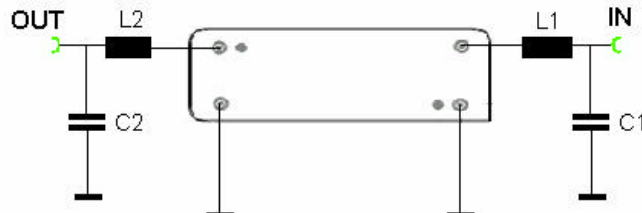

L1=L2=139nH
C1=C2=22pF

Source/Load Impedance = 50 ohm