

11-MD125

Version : A.003
Issue Date : 2004/09/01
Total Page : 12

2 Channel Low Saturation & Constant Current DC Motor Driver



新竹市展業一路9號4樓之3

SILICON TOUCH TECHNOLOGY INC.

9-4F-3, Prosperity Rd I, Science-Based Industrial Park

Hsinchu, Taiwan, R.O.C.

Tel : 886-3-5727171 Fax : 886-3-5727390

Pin NO.	Pin Name	Description
1	IN1	Input pin start constant current mode
2	IN2	Input pin that determines forward/reverse mode
3	IN3	Holding 1 output pin (output current settling)
4	IN4	Input pin that determines DC driving mode
5	IN5	Input pin that determines DC driving mode
6	IAD	AMP positive input pin
7	VREF	Reference voltage output pin
8	HO1	Holding 1 output pin (output current settling)
9	NC	No connection
10	CF	Oscillation protech capacitance
11	VB1	Power supply pin for constant current output driver
12	VDD	Power supply pin for controller.
13	IM	Current sense resistor
14	IO2	Current driving 2
15	IO1	Current driving 1
16	VO2	DC driving 2
17	VO1	DC driving 1
18	PG	Driver ground
19	SG	Controller ground
20	VB2	Power supply pin for DC output driver

Absolute Maximum Ratings (Unless otherwise noted, $T_A=25^{\circ}\text{C}$)

Characteristic	Symbol	Rating	Unit
Supply Voltage	V_{DD}	5.5	V
	V_B	7	V
Input Voltage	V_{IN}	$V_{DD}+0.4$	V
I_O Peak Current	I_{OPeak}	1.5	A
I_{ODC} Current	I_{ODC}	0.45	A
Power Dissipation	P_D	700	mW
Operating Temperature Range	T_{OPR}	-40 ~ 125	$^{\circ}\text{C}$
Storage Temperature Range	T_{STG}	-65 ~ 150	$^{\circ}\text{C}$

Electrical Characteristic

(Unless otherwise noted, $T_A = 25^\circ\text{C}$ & $V_{DD} = V_B = 3\text{V}$)

Characteristic	Sym.	Condition	Limit			Unit
			Min.	Typ.	Max.	
Supply Voltage	V_{DD}		2.5	3	5.5	V
	V_B		2.5	3	5.5	V
Supply Current (I_{DD})	I_{STB}	$V_{IN1, IN4, IN5} = L$		0.1	1	μA
	I_{ACT1}	$V_{IN1} = H, V_{IN4, IN5} = L$		0.4	1	mA
	I_{ACT2}	$V_{IN1} = L, V_{IN4, IN5} \neq L$		0.2	1	mA
	I_{ACT3}	$V_{IN1} = H, V_{IN4, IN5} \neq L$		0.5	1	mA
Reference Voltage Circuit						
Reference Voltage	V_{REF}	$R_{VREF} = 30\text{k}, V_{DD} = 3\text{V}$	1.10	1.23	1.27	V
HO1 Voltage	V_{HO1}	$R_{HO1} = 30\text{k}, V_{DD} = 3\text{V}$	1.10	1.23	1.27	V
ENA / IN1 / IN2 / IN3 Input Terminal ($T_J = 25^\circ\text{C}$)						
Input Voltage "H"	V_{IH}	-	$0.8 \cdot V_{DD}$	-	$V_{DD} + 0.4$	V
Input Voltage "L"	V_{IL}	-	-0.4	-	$0.2 \cdot V_{DD}$	V
Input Current "H"	I_{IH}	$V_{IN} = V_{DD}$	-	-	± 5	μA
Input Current "L"	I_{IL}	$V_{IN} = 0\text{V}$	-	-	± 5	μA
IO1 / IO2 Output Terminal ($T_J = 25^\circ\text{C}$)						
Output Current1	I_{O1}	$I_{AD} = 0.3\text{V}, R_{IM} = 1\Omega$	282	300	318	mA
Output Current1	I_{O2}	$I_{AD} = 0.2\text{V}, R_{IM} = 1\Omega$	188	200	212	mA
Output Voltage (upper + lower)	V_{OUT}	$I_{OUT} = 300\text{mA}$	-	0.4	0.8	V
VO1 / VO2 Output Terminal ($T_J = 25^\circ\text{C}$)						
Output Voltage (upper + lower)	V_{OUT}	$R_{Load} = 10\Omega$	-	0.4	0.8	V
Thermal Protection Circuit						
Protection Temperature	T_{TSD}	$V_{IN1} = H, V_{IN4, IN5} \neq L$		160		$^\circ\text{C}$

Truth Table

Constant current driving

INPUT			OUPUT			MODE
IN1	IN2	IN3	IO1	IO2	HO1	
L	-	-	OFF	OFF	OFF	STANDBY
H	H/L	H	H/L	L/H	ON*	Shutter (Current 1)*
	H/L	L	H/L	L/H	OFF*	Shutter (Current 2)*

- : Don't care

*HO1 : ON Output voltage=1.23V (= Vref).

: OFF Output = Impedence.

*The constant current level is dependent on the connections of external resistors R_{IM} , R_A , R_B and R_C in the block diagram.

Saturation voltage driving

INPUT		OUPUT		MODE
IN4	IN5	VO1	VO2	
L	L	OFF	OFF	STANDBY
L	H	L	H	REVERSE
H	L	H	L	FOWORD
H	H	H	H	BREAK

- : If IN1=L, IN4=L and IN5=L, the driver will be shutdown and Vref become high impedence.

Block Diagram

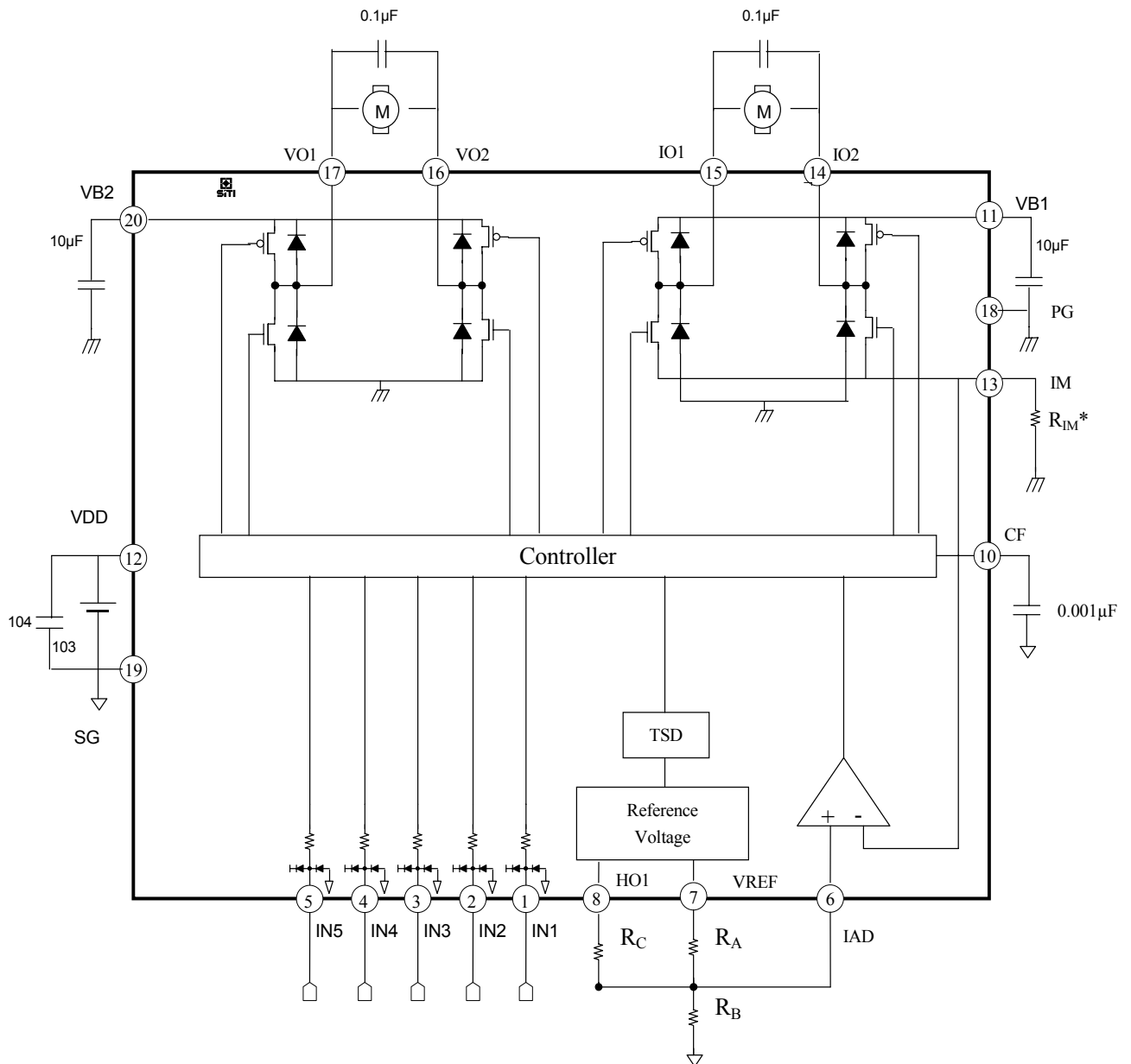

*The current value can be justified with V_{IAD} divided by R_{IM} .

*When $IN3 = L$, $HO1 = \text{High Impedance}$, $V_{IAD} = V_{ref} * R_B / (R_A + R_B)$, and $I_{OUT} = V_{IAD} / R_{IM}$.

*When $IN3 = H$, $HO1 = V_{ref}$, $V_{IAD} = V_{ref} * R_B / [(R_A // R_C) + R_B]$, and $I_{OUT} = V_{IAD} / R_{IM}$

Application Circuit

- For one saturation channel and one fixed constant current channel application, the circuit diagram is suggestion as below.

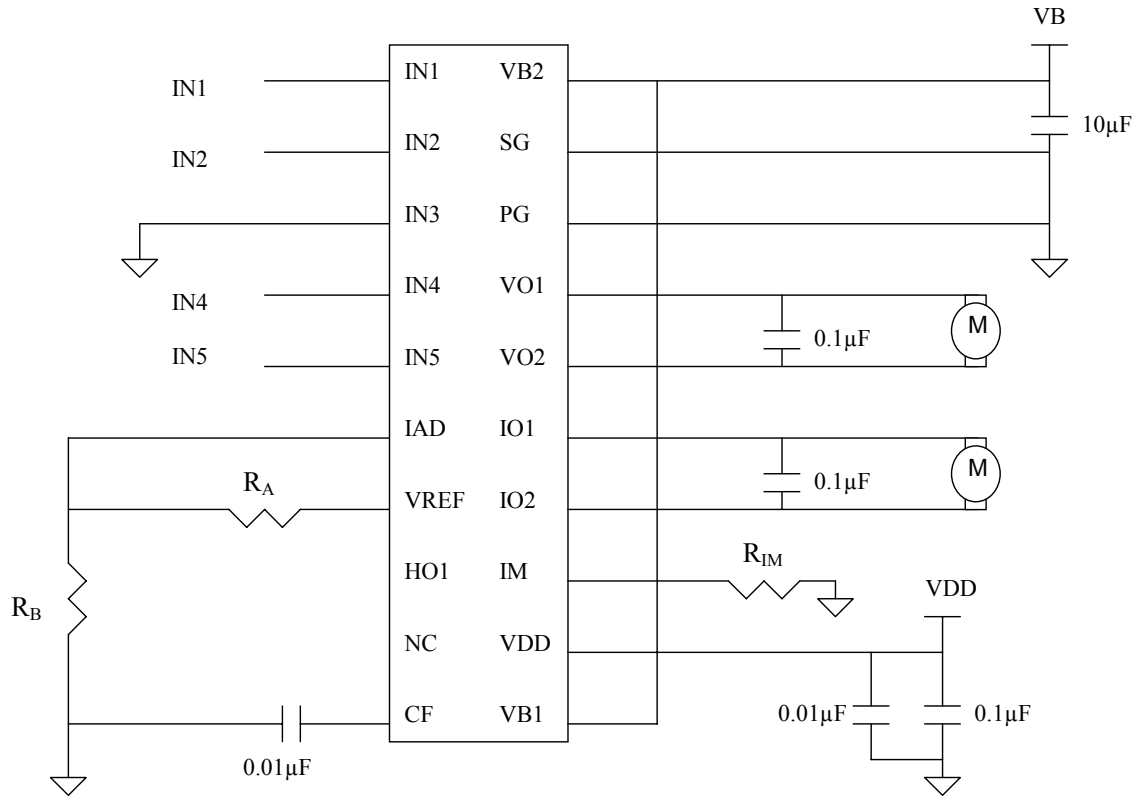

* For example, to get constant current output I_{OUT} about 200mA,
 set $R_A = 8.2\text{k}\Omega$, $R_B = 1.6\text{k}\Omega$, $R_{IM} = 1\Omega$,
 thus, $V_{IAD} = 1.23/6.125 = 0.201\text{V}$ and $I_{OUT} = 0.201/1 = 201\text{mA}$.

- For one saturation channel and one constant current channel with two current values application, the circuit diagram is as below.

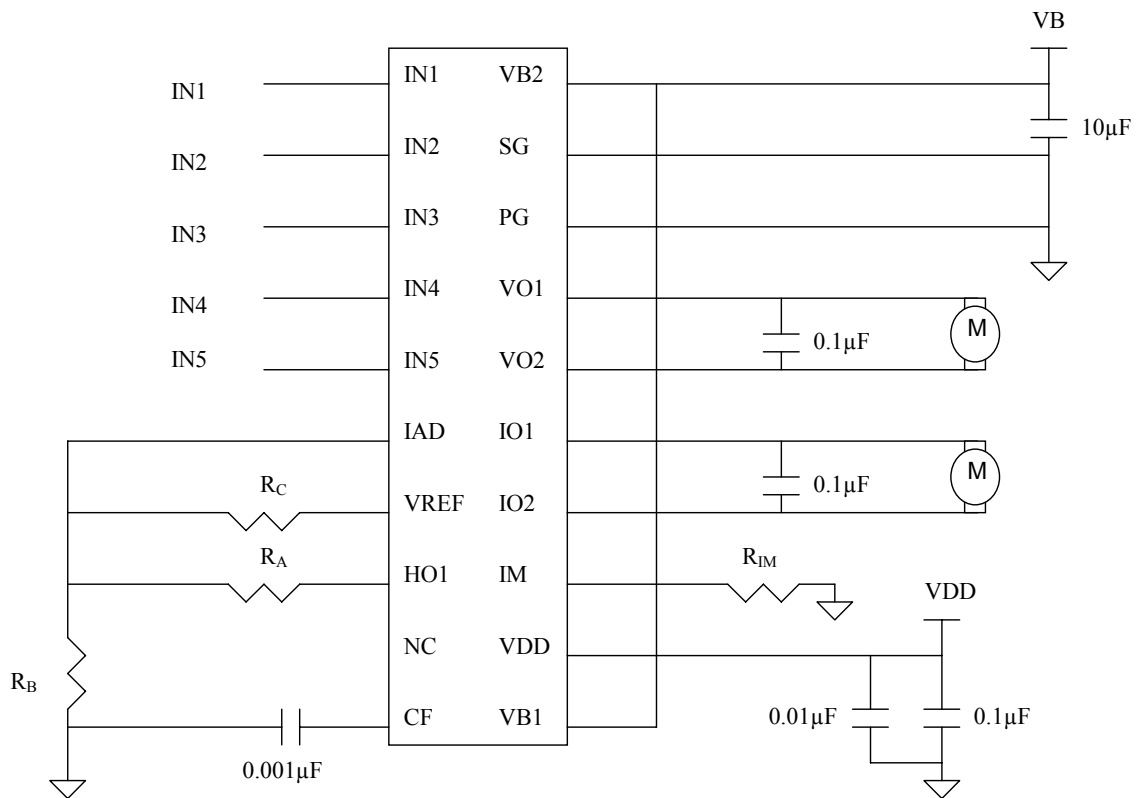

* For example, to get two constant current level I_{OUT} about 200mA or 300mA, set $R_A = 8.2K\Omega$, $R_B = 1.6K\Omega$, $R_C = 13K\Omega$, $R_{IM} = 1\Omega$.

If $IN3=L$, $V_{IAD} = 1.23/6.125 = 0.201V$ and $I_{OUT} = 0.201/1 = 201mA$.

If $IN3=H$, $V_{IAD} = 1.23/4.142 = 0.297V$ and $I_{OUT} = 0.297/1 = 297mA$.

Application Notes

1. In multiple power supply application, the voltage of VB1 and VB2 can be used at different value. The power supply VB1 is used for constant current channel and VB2 is used for saturation channel.
2. For constant current mode application, Gnd of R_{IM} and PG have better to be connected to Gnd of system power as close as possible, because I_{OUT} is sensitive with V_{IAD} referred to V_{ref}, when large current flowing into SG will result in significant variation of V_{ref}. The output current is set by $I_{OUT} = V_{IAD} / R_{IM}$. The V_{IAD} can be set by reference voltage with external serial proportional resistors.
3. The power dissipated by the IC varies widely with the supply voltage, the output current, and loading. It is important to ensure the application does not exceed the allowable power dissipation of the IC package. The recommended motor driver power dissipation versus temperature is depicted as follows:

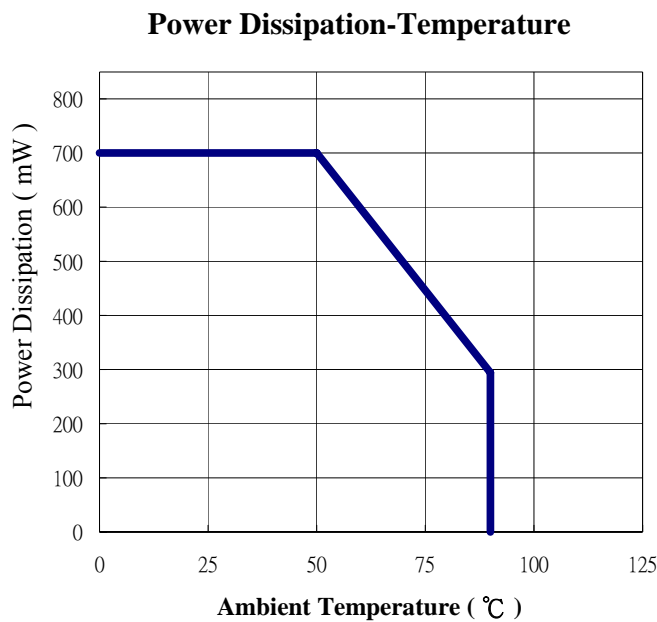

Package Specifications(SSOP-20)

(20-pin SSOP)

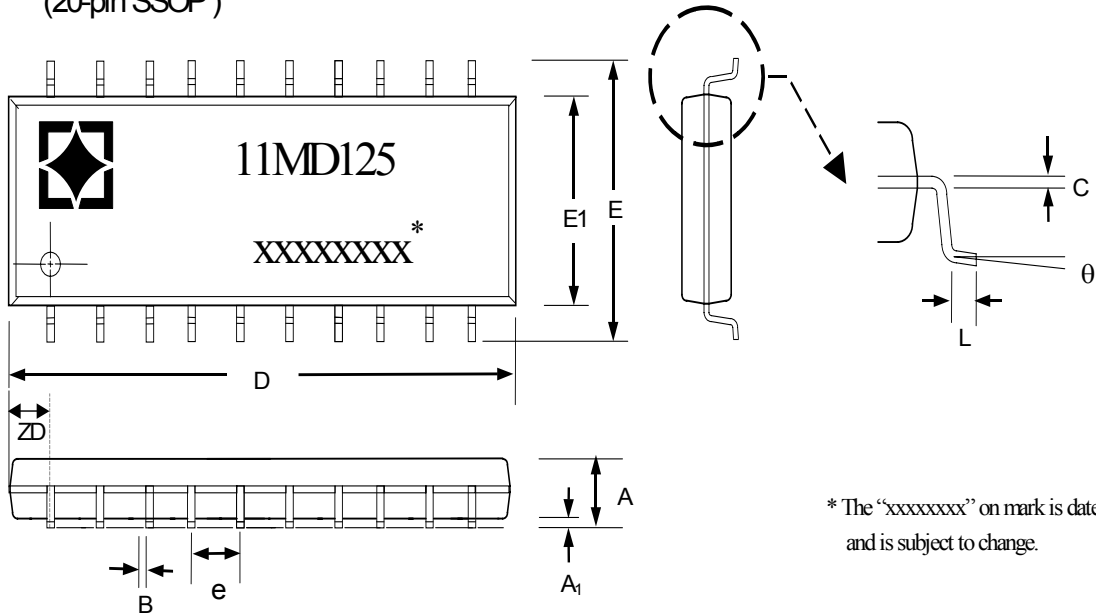

* The "xxxxxxx" on mark is date code and is subject to change.

SYMBOL	Dimensions in Millimeter		
	MIN	NOM	MAX
A	1.35	1.63	1.75
A ₁	0.10	0.15	0.25
A ₂	—	—	1.50
B	0.20	—	0.30
c	0.18	—	0.25
D	8.56	8.66	8.74
E	5.79	5.99	6.20
E1	3.81	3.91	3.99
e	0.635 BASIC		
L	0.41	0.635	1.27
ZD	1.4732REF		
θ	0°	—	8°

Package Specifications(TSSOP-20)

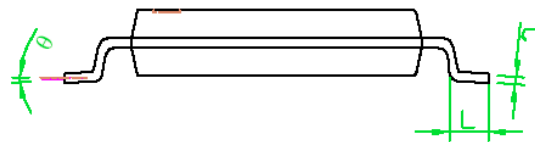
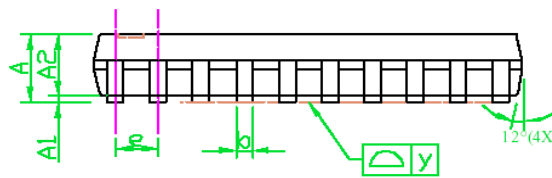
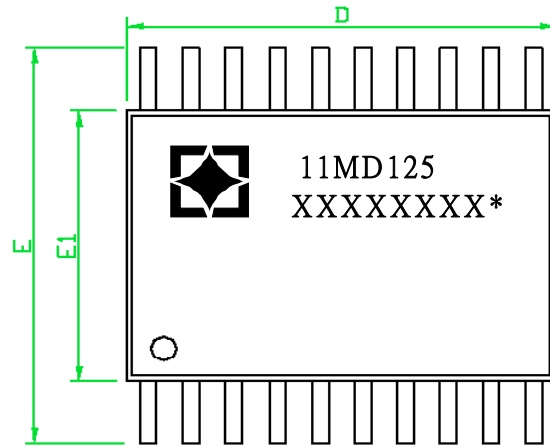

SYMBOL	Dimensions in Millimeter		
	MIN	NOM	MAX
A	—	—	1.20
A ₁	0.05	—	0.15
A ₂	0.80	1	1.05
b	0.19	—	0.30
C	0.09	—	0.20
D	6.40	6.50	6.60
E	6.20	6.40	6.40
E1	4.30	4.40	4.50
e	—	0.65	—
L	0.45	0.60	0.75
y	—	—	0.10
θ	0°	—	8°

The products listed herein are designed for ordinary electronic applications, such as electrical appliances, audio-visual equipment, communications devices and so on. Hence, it is advisable that the devices should not be used in medical instruments, surgical implants, aerospace machinery, nuclear power control systems, disaster/crime-prevention equipment and the like. Misusing those products may directly or indirectly endanger human life, or cause injury and property loss.

Silicon Touch Technology, Inc. will not take any responsibilities regarding the misuse of the products mentioned above. Anyone who purchases any products described herein with the above-mentioned intention or with such misused applications should accept full responsibility and indemnify. Silicon Touch Technology, Inc. and its distributors and all their officers and employees shall defend jointly and severally against any and all claims and litigation and all damages, cost and expenses associated with such intention and manipulation.