

# Electrical Design Considerations for SuperFlux LEDs

## Table of Contents

### Overview

Summary	2
Electrical Design Process Overview	3
Circuit Design Overview	4
Worst-Case Circuit Analysis and Validation	5
<i>Comparison of Different Methods of Worst-Case Circuit Analysis</i>	5
<i>Characterization of Prototype LED Signal Lamp</i>	7
<i>Validation of LED Signal Lamp</i>	7
Key Concepts for Electrical Design of LED Signal Lamps	8
<i>Resistor-Limited Drive Circuits</i>	8
<i>Effect of LED String Length on Forward Current Regulation</i>	9
<i>Forward Current Variations between LED Emitters in an Array</i>	10
<i>EMC Transient Protection Circuits</i>	12
<i>Stop/Tail Drive Circuits</i>	12

### Theory

Electrical, Optical, and Thermal Characteristics of LED Emitters	13
LED Emitter Modeling	16
<i>Linear Forward Voltage Model</i>	17
<i>Luminous Flux Models Versus Forward Current and Temperature</i>	18
<i>Thermal Resistance Models</i>	19

### Applications

Resistive Current Limiting	21
CHMSL Design Example	24
EMC Transient Protection	27
Special Considerations for Dual Luminous Intensity Operation	29
<i>Luminous Flux Variations at Low Currents</i>	29
<i>PWM Drive Circuit for Tail Functions</i>	30
Current and Voltage Regulator Circuits	31
<i>Operation of Shunt, Series-Pass, and Switching Regulators</i>	32

# Overview

---

## Summary

---

The electrical design is part of the overall signal lamp design. The electrical design of an LED signal lamp has several objectives. The first objective is to operate the individual LED emitters at sufficient drive current in order to generate sufficient luminous flux to meet the lighting requirements. The second objective should be to limit the forward current through the individual LED emitters so as not to exceed their maximum internal junction temperatures and maximum dc forward currents under worst-case conditions of ambient temperature and input voltage. In addition, the electrical design should protect the LED array from automotive EMC transients. Finally, the electrical design should provide good intensity matching within the LED array. The result of achieving these objectives will be a maintenance-free LED signal light that operates reliably for the lifetime of the passenger vehicle or truck.

Application Brief AB20-3 has been written to simplify the electrical design of LED signal lamps and is part of the Application Brief AB20 series. This application note has been divided into three major blocks—Overview, Theory, and Applications. The Overview consists of five sections that discuss the electrical design process and key electrical design concepts. Theory consists of two sections that give an in-depth overview of the electrical, optical, and thermal properties of LED emitters and mathematical modeling of their operation. Applications consist of four sections that cover specific types of circuit designs commonly

used in LED signal lamps and related circuit design issues.

In addition to AB20-3, two companion electrical design application notes are also available.

AB20-3A, titled “Advanced Electrical Design Models,” discusses forward voltage models that are more accurate and usable over a larger range of forward currents than the simple linear models shown in the “LED Emitter Modeling” section. In addition, AB20-3A derives several additional thermal-modeling equations from the basic equations shown in the “LED Emitter Modeling” section.

Application Note titled AB20-3B “SuperFlux LED Forward Voltage Data” gives worst-case forward voltage data for SuperFlux and SnapLED70 emitters. There are several potential electrical models for LED emitters (linear, diode equation models, etc.), each one optimized for an expected range of forward currents, and various levels of “worst-casing” (i.e. min/max, average, average  $\pm$  one, two, three standard deviations, etc.). In order to accommodate these various needs, the data presented in AB20-3B gives the nominal forward voltage and expected forward voltage range for each SuperFlux LED characterized over a range of forward currents up to 70 mA. From this data, the desired electrical model can easily be generated. The latest forward voltage data for SuperFlux LED emitters is available from your local Lumileds

Lighting or Agilent Technologies sales engineer or from the following URL:

<http://www.lumileds.com>

Note: For best matching within an array, SuperFlux and SnapLED 70 emitters should be operated at forward currents over 20 mA (40 mA for SnapLED 150). At forward currents below 20 mA (40 mA for SnapLED 150), variations in luminous efficiency and

forward voltage can cause luminous intensity matching variations within groups of SuperFlux emitters from the same luminous flux and forward voltage category. For this reason, Lumileds Lighting does not warrant LED performance at currents less than 20 mA (40 mA for SnapLED 150) and strongly discourages these designs.

## Electrical Design Process

---

The electrical design is part of the overall signal lamp design process described in AB20-1.

The electrical design consists of several discrete steps. The first step is to determine the circuit topology and to generate an electrical schematic of the overall circuit. First, the circuit topology must be determined. Circuit topology refers to the arrangement of electrical components on the electrical schematic. Next, the circuit must be designed. Circuit design is the process where the electrical components are selected and component values are determined. Third, the operation of the circuit must be analyzed. Circuit analysis refers to the mathematical analysis of the variations in voltage and current through the electrical components due to variations in applied voltage and component tolerances. The fourth step is to create a breadboard of the circuit and to measure the forward current, light output, and thermal properties of the entire signal. If the maximum junction temperature or the maximum DC forward current of any of the LED emitters is exceeded, the reliability of the LED signal lamp may be compromised. Thus, if the circuit validation tests indicate that these limits are

exceeded, portions of the electrical or thermal design may need to be iterated in order to reduce the forward current and/ or junction temperature. Finally, additional prototypes of the signal lamps should be constructed and subjected to the appropriate reliability validation tests.

The most important circuit topology considerations include:

- Number of LED emitters in series
- Whether LED emitters are connected in individual series-strings, or in cross-connected series strings
- Method of current limiting (i.e. resistors or active circuit)
- Method of EMC protection (if any)
- Method of dimming, such as for a combined Stop/ Tail signal

Circuit design is the solution of several simultaneous linear equations that model the forward current through each loop or node of the circuit. The solution of these equations determines the values of electrical components that drive the LED array at the desired forward current at the specified external supply voltage.

Different mathematical models can be used to model the forward voltage of the LED emitters depending on the accuracy and dynamic range needed.

Circuit analysis uses the same types of simultaneous linear equations used in the electrical design. However, circuit analysis generally assumes that the external voltage applied to the circuit, the values of electrical components, and the ambient temperature can vary over some predetermined range. Circuit analysis can be done using “worst-case” electrical models for the electronic components

and LED emitters. With this technique, the voltages and currents through each component can be determined based on the expected minimum and maximum limits of component values in the circuit. Another technique is to use a Monte Carlo simulation. With this method the voltages and currents through each component are determined for random combinations of component values in the circuit. Then the results for a large number of Monte Carlo simulations are statistically tabulated. The Monte Carlo simulation method gives a better estimate of the expected manufacturing variations for the circuit.

## Circuit Design Overview

---

As stated earlier, the first step in the electrical design is to pick one of the circuit topologies. Next, the operation of the circuit can be modeled with a series of simultaneous linear equations that describe the current through each electronic component as a function of component values and applied voltage. For circuit design, it is usually assumed that all LED emitters have the same electrical characteristics, which greatly simplifies the mathematical modeling.

In order to ensure reliable operation, the maximum forward current through the LED emitters should not exceed the maximum value obtained from Figure 4 in the HPWx-xx00 data sheet. Note that the maximum forward current of the LED emitters is based on the maximum ambient temperature,  $T_A$ , the maximum input voltage, and the thermal resistance,  $R\theta_{JA}$ , of the LED signal light assembly.

As will be shown in the section “Key Concepts for the Electrical Design of LED Signal Lamps” the different circuit topologies provide different levels of forward current regulation and overall electrical power consumption. Circuits with poor forward current regulation would require the LED emitters to be driven at a lower forward current at the nominal input voltage than would circuits with better forward current regulation (so as not to exceed the maximum forward current at the maximum input voltage). Circuits with higher amounts of power consumption would tend to have higher internal self-heating (unless the circuitry is located outside the signal lamp housing), which would also tend to reduce the maximum forward current of the LED emitters. At this point, it may be desirable to evaluate several different circuit topologies on paper and see which one gives the “best” overall results.

If the signal lamp will be exposed to high-voltage EMC transients, then the appropriate protection circuitry can be added to the basic circuit

chosen. Worst-case forward and reverse transient currents can be estimated using the linear forward current model for positive

transients and the minimum breakdown voltage specification,  $V_{BR}$ , on the data sheet for negative transients.

## Worst-Case Circuit Analysis and Validation

---

The next step in the electrical design should be an analysis of the forward current through the LED emitters at worst-case input voltage and operating temperature extremes using worst-case component tolerances. All of the active and passive electronic components used in the circuit design can be modeled with their worst-case minimum and maximum values. This analysis serves several purposes. First, it determines whether the forward current is less than the maximum dc forward current under all operating conditions. Secondly, it determines the change in light output of the signal lamp under the same conditions. Finally, it can be used to determine the worst-case matching within the LED array.

This worst-case analysis can be done in several different ways. One approach is to use worst-case values for one or more LED emitters in the array such as to cause worst-case current matching between LED emitters or to establish the maximum or minimum forward current through individual LED emitters. The problem with this approach is that probability of this occurrence actually happening can be quite low. If the probability of getting worst-case LED emitters is very small, then the probability of both minimum and maximum worst-case LED emitters occurring in the same circuit assembly is even lower. Furthermore, for the worst-case variations in forward currents to actually occur, these worst-case LED emitters must both be randomly assembled into certain parts of the

circuit. Thus, the actual occurrence of these worst-case conditions could be extremely small.

Another approach to worst-case analysis is to characterize a number of LED emitters and determine the appropriate forward voltage model for each one. Then using a Monte-Carlo simulation, random combinations of these emitters can be assembled into a “paper” circuit and the actual forward currents can be calculated for the circuit based on the corresponding forward voltage models. Then the results from multiple simulations can be tabulated. This approach provides a much better understanding of the forward current variations that would occur in actual practice.

In general, within arrays of LED emitters, the maximum forward current occurs at the maximum input voltage with the minimum value of the current limiting resistor and minimum forward voltage model for the LED emitters. Likewise, the minimum forward current occurs at the minimum input voltage with the maximum value of the current limiting resistor and maximum forward voltage model for the LED emitters.

The worst-case forward current variations for different LED emitters within the array is determined by the circuit topology, the drive current, and the variation in electrical characteristics of the individual LED emitters in the array. When several LED emitters are

connected in series, the worst-case minimum forward current would occur when all LED emitters in a given series string have the worst-case maximum forward voltage. Likewise, the worst-case maximum forward current would occur when all LED emitters in another series-string have the worst-case minimum forward voltage. For these series-string circuits, the likelihood of all LED emitters being at their worst-case forward voltage extremes is quite low. When LED emitters are connected in parallel, the forward current through each LED will vary somewhat from the average forward current so as to generate the same forward voltage across all LED emitters in the parallel grouping. The worst-case forward current variations occur when one LED emitter has the worst-case minimum forward voltage and another LED emitter in the same parallel grouping has the worst-case maximum forward voltage.

SuperFlux and SnapLED 70 emitters are categorized for forward voltage at 70 mA. As might be expected, the smallest forward current variations within an array of SuperFlux or SnapLED 70 LED emitters occur at drive current approaching 70 mA. Similarly, SnapLED 150 emitters are categorized for forward voltage at 150 mA, so the best matching occurs at 150 mA. At lower forward currents, the variations in forward current within the LED array become larger—especially when LED emitters are connected in parallel. For series-string circuits, acceptable forward current variations can usually be achieved over forward currents over a range of 20 to 70 mA (40 to 150 mA for the SnapLED 150). However, when LED emitters are connected in parallel, acceptable forward current variations can be achieved only over a

range of 35 to 70 mA (70 to 150 mA for the SnapLED 150). These matching effects are covered in more detail in the section “Key Concepts for Electrical Design of LED Signal Lamps.”

The reader will need to determine whether the assumptions used for the worst-case designs are reasonable. It is possible to design with such large tolerances, that the worst-case design results in an over-designed circuit. Over-designing occurs if significant cost is added to the assembly in order to protect against the remote possibility of occurrences that might never happen in practice. In the case of LED signal lamps, over-designing might result in many more LED emitters being added to the array than needed. The best example might be where the designer chooses an extremely high worst-case input voltage and maximum ambient temperature. Then, the use of the suggested design process in the “Resistive Current Limiting” section would result in a fairly small design current at the design input voltage. This design current would require a large number of LED emitters to achieve the desired light output from the array. Or the assumptions used for the worst-case input voltage and ambient temperature might require the use of a more expensive constant current drive circuit, where with more reasonable assumptions a resistive circuit could have been used. These concerns about over-designing by using excessive tolerances on input voltage and ambient temperature also can be applied to LED emitter tolerances. For example, the probability of all LED emitters in a given array being at their worst-case minimum or maximum limits is very small but still is greater than zero. If every LED emitter is assumed to be at the worst-case minimum extreme, then the external current

limiting resistor may be chosen to overly restrict the forward current through the array. Another possibility is that if the circuit is designed to accommodate every LED emitter in a given array being at their worst-case minimum or maximum limits, then design might eliminate several potential circuit topologies because of excessive light output variations. In practice, the likelihood of these conditions actually occurring is so small, that the design process might have eliminated more cost effective circuit topologies. For this reason, Lumileds Lighting recommends that worst-case design be used as a development tool in conjunction with characterization and validation of the signal lamp assembly.

Following this paper design, a working prototype LED signal light can be constructed. This prototype serves several purposes. First, it allows verification of the electrical design. The forward current can be measured at different input voltages and compared with the paper electrical design. Second, it allows verification of the optical design. In AB20-1 section, "Estimating the Number of LED Emitters Needed," assumptions were made for the

optical transmission losses. The prototype allows these assumptions to be measured. Third, the working prototype allows the thermal properties of the LED signal light to be evaluated. The thermal resistance,  $R_{q_{PIN A}}$ , can be measured by attaching thermocouples to the cathode pins of several LED emitters in the array.

Based on the electrical, optical, and thermal measurements of the working prototype, additional iterations of the design may be required. These design iterations will further refine the estimates for the electrical component values, the number of LED emitters needed for the signal lamp, and the thermal resistance of the signal lamp. Also, it may be necessary to evaluate improved optical designs and methods for improving the thermal properties of the LED signal lamp assembly. For more information on thermal design, the reader is encouraged to review AB20-4 "Thermal Management Considerations for SuperFlux LEDs." For more information on optics design, the reader is encouraged to review AB20-5 "Secondary Optic Design Considerations for SuperFlux LEDs."

## Key Concepts for Electrical Design of LED Signal Lamps

Presently, most current LED signal lamp designs use resistive current limiting for the LED array. Since most LED signal lamps are driven from 12 to 24 V dc and require several LED emitters, the emitters can be connected in series and share the same supply current. Some of the most common circuit configurations are shown in Figure 3.1. The series connected string circuit in Figure 3.1a uses a separate current limiting resistor for each string of  $y$  LED emitters. The paralleled-string circuit in Figure 3.1b uses a single resistor for the entire LED array. Note that this circuit uses  $x$  strings with  $y$  LED emitters per string. The cross-connected paralleled string circuit shown in Figure 3.1c has one or more cross connections between the strings of LED emitters. A mechanical analogy to this circuit is that the circuit looks like a “ladder” with each cross connection being a “rung” on the “ladder.” In the diagram,  $z$ , refers to the number of series connected LED emitters between each “rung” with  $1 \leq z \leq y$ . Most CHMSL designs use either several series connected strings (Figure 3.1a) or several cross-connected series strings (Figure 3.1c) with  $z = 1$ . Note that in order to obtain the same forward current for all of LED emitters, both of the circuits shown in Figure 3.1b and Figure 3.1c need to have the same number of LED emitters in each string and each “rung” for Figure 3.1c.

Note that if all LED emitters have identical electrical forward characteristics, then the value of the external current limiting resistor,  $R$ , is equal to:

$$R = \frac{V_{IN} - yV_F(I_F) - V_D}{xI_F} \quad (3.1)$$

Where:

$V_{IN}$  = input voltage applied to the circuit

$V_F$  = forward voltage of LED emitter at forward current  $I_F$

$V_D$  = voltage drop across optional reverse transient EMC protection diode

$y$  = number of series connected LED emitters

$x$  = number of paralleled strings

Thus for a given  $I_F$ , the value of  $R$  depends both on the number of LED emitters per string as well as the number of paralleled strings.

As shown later in the section “LED Emitter Modeling” the forward voltage of an LED emitter can be mathematically modeled by the following equation:

$$V_F \approx V_O + R_S I_F$$

Where:

$V_O$  = turn-on voltage of each LED emitter

$R_S$  = series resistance of each LED emitter

This equation is known as the linear forward voltage model since it models the forward voltage of the LED with a straight line. In using this model it is important to remember that it can only be used over a specific range of forward currents. Outside of this range, the model will give misleading results. Using the linear forward voltage model, this equation can be rewritten as:

$$R = \frac{V_{IN} - yV_O - V_D}{xI_F} - \frac{y}{x}R_S \quad (3.2)$$



The number of LED emitters selected per string ( $y$ ) affects the change in the forward current of the LED emitters as the input voltage varies over some range. In general, as the value of  $y$  is increased, the change in forward current becomes larger due to the same input voltage variation. In addition, when the input voltage is less than ( $yV_D$ ) the forward current through each LED emitter is approximately equal to zero. As the value of  $y$  is increased, this "threshold" voltage increases. Figure 3.2 shows the change in forward current

through each string of LED emitters as a function of input voltage. Figure 3.2 shows string lengths ranging from 2 to 6 emitters. Note that series-strings with 5 and 6 emitters have the largest change in forward current and highest "threshold voltage." Since the forward voltage of the LED emitters varies slightly over temperature, then the forward current through each LED string will change slightly over temperature. Circuits with longer string lengths will have a slightly larger forward current change over temperature.

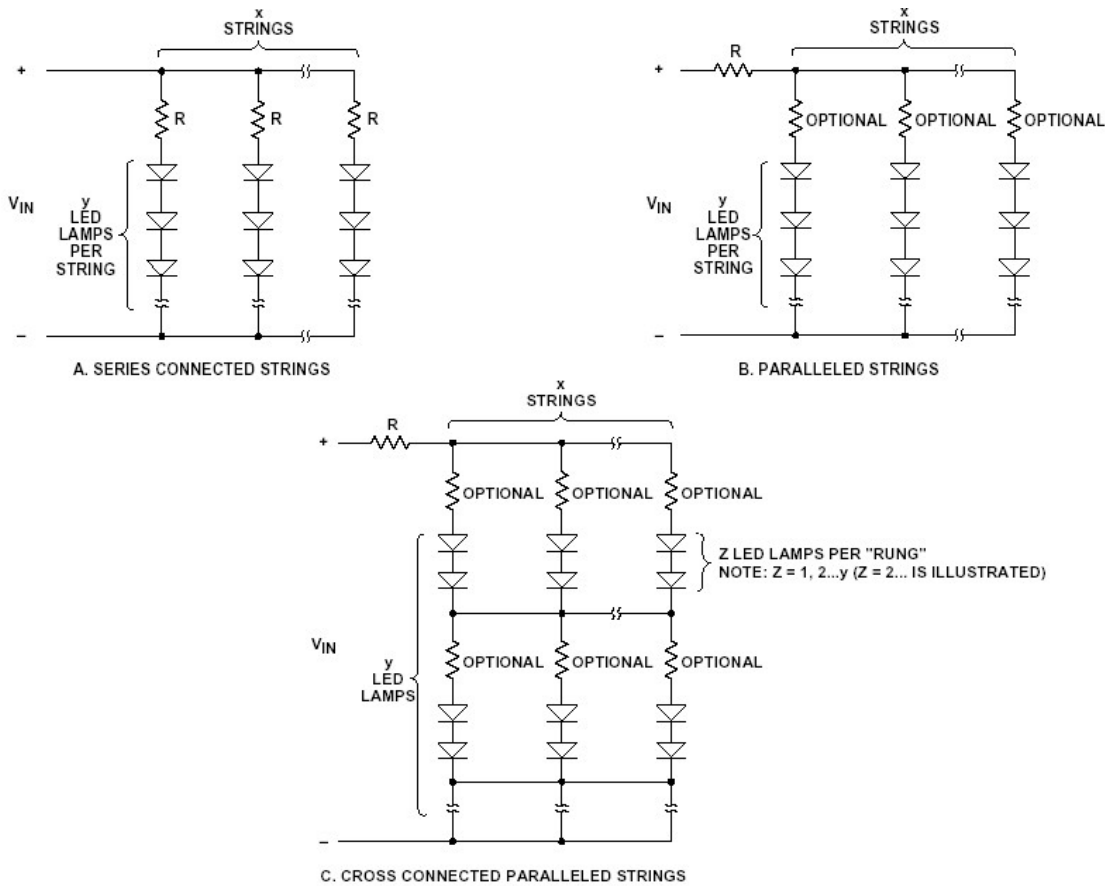

Figure 3.1 Circuit Configuration of LED Arrays Used in LED Signal Lamps.

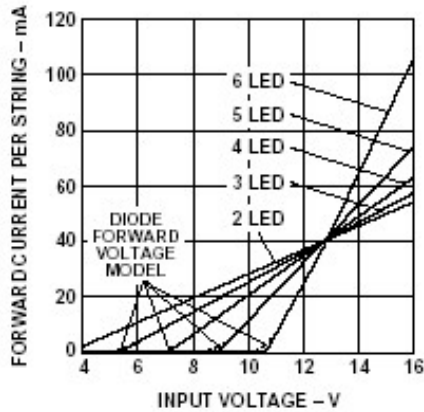

Figure 3.2 Forward Current Through String of HPWA-xHOO LED Emitters versus Applied Voltage.

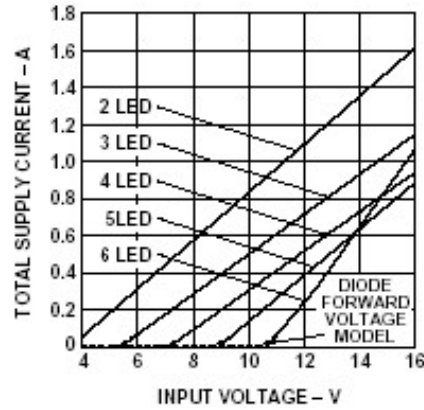

Figure 3.3 Total Supply Current versus Supply Voltage for Sixty HPWA-xHOO Emitter LED Signal Lamp Array Driven in Series Strings with Two, Three, Four, Five, or Six Emitters per String.

The number of LED emitters per string also affects the total supply current. For a fixed number of LED emitters longer string lengths result in fewer total strings and thus a lower total supply current. Figure 3.3 shows the total supply current for the series-string configurations in Figure 3.2. Figure 3.3 assumes a total of 60 LED emitters, thus 2-LED strings would require 30 strings, 3-LED strings would require 20 strings, etc. Note that the total supply current is much higher for series strings with 2 and 3 emitters.

As shown by Figures 3.2 and 3.3, the choice of the number of emitters per string is a tradeoff between the regulation of forward current due to input voltage variations and the total supply current for the LED array. Small string lengths give excellent forward current regulation, but require a higher supply current. Long string lengths provide poor forward current regulation but require less supply current. For these reasons, most 12 V resistive limited designs use three or four LED emitters per series string ( $\gamma = 3$  or 4).

Variations in the forward voltage characteristics of the individual LED emitters can lead to forward current variations within the LED array. These forward current variations directly affect the luminous flux output of each LED emitter and can cause noticeable luminous intensity variations within the LED array. These random variations in forward voltage characteristics affect the three circuits shown in Figure 3.1 differently.

The “series-string” circuit shown in Figure 3.1a is least affected by random forward voltage variations between the LED emitters because the forward voltages of all LED emitters in a given string are averaged together. In many cases, one emitter with a high forward voltage can cancel out another emitter in the same *series-string* with a low forward voltage. In addition, the voltage drop across the current limiting resistor,  $R$ , is much higher than the combined voltage drops across the series resistors,  $\gamma R_s$ . Thus, small variations in  $R_s$  only cause small variations in the forward current through the series string. Because SuperFlux and SnapLED 70 emitters are categorized for forward voltage at 70 mA (150 mA for the SnapLED 150), the smallest

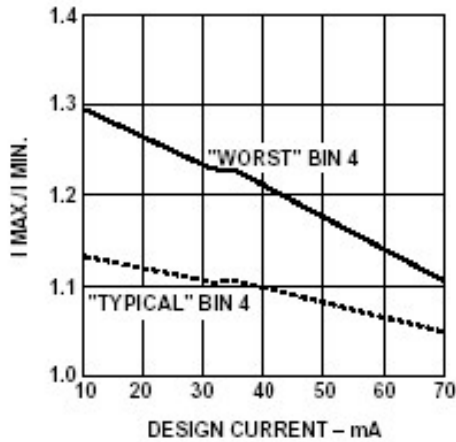

Figure 3.4 Worst-Case and Typical Variations in Forward Current Between Two Strings of HPWT-xH00 LED Emitters Driven with Individual Current-Limiting Resistors per String (Figure 1a Circuit, with  $y=4$ ).

forward current variations between adjacent series-strings of LED emitters occur at a drive current of 70 mA (150 mA for the SnapLED 150). However, the forward current matching between adjacent strings is quite good even at forward currents as low as 10 mA (20 mA for the SnapLED 150). Figure 3.4 shows the worst-case forward current variation between two LED strings constructed using four LED emitters per string. The worst-case calculations assume that all HPWT-xH00 emitters are from the same forward voltage category and one string uses four “minimum” forward voltage emitters and the other string uses four “maximum” forward voltage emitters. The typical calculations assume that all HPWT-xH00 emitters are from the same forward voltage category and one string consists of two “minimum” forward voltage emitters and two “typical” forward voltage emitters and the other string consists of two “maximum” forward voltage emitters and two “typical” forward voltage emitters. Due to potential variations in luminous flux output at low currents, Lumileds Lighting recommends a minimum forward current of 20 mA for

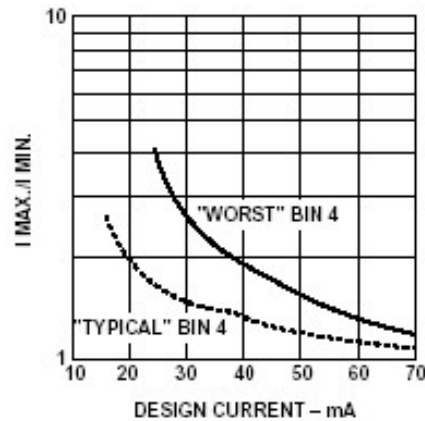

Figure 3.5 Worst-Case and Typical Variations in Forward Current Between 16 HPWT-xH00 LED Emitters Driven in a Cross-Connected Paralleled String Configuration (Figure 1c Circuit with  $x = y = 4$ ,  $z = 1$ ).

SuperFlux and SnapLED 70 emitters and 40 mA for SnapLED 150 emitters (see the section “Electrical, Optical, and Thermal Characteristics of LED Emitters”).

The “paralleled-string” circuit shown in Figure 3.1b and the “cross-connected series string” circuit shown in Figure 3.1c do not regulate the forward current as well as the “series-string” circuit. When two or more LED emitters are connected in parallel, the forward current through each emitter will be somewhat higher or lower than the average forward current through them so as to force the forward voltage across them to be the same. Again, because SuperFlux LED and SnapLED 70 emitters are categorized for forward voltage at 70 mA (150 mA for the SnapLED 150), the smallest forward current variations between adjacent LED strings (Figure 3.1b circuit) or between LED emitters in the same “rung” (Figure 3.1c circuit) occur at a drive current of 70 mA (150 mA for SnapLED 150). The variations in forward currents become much worse at lower drive currents. These variations in forward currents can cause unacceptable

luminous intensity variations even using LED emitters from the same forward voltage and luminous flux category. Figure 3.5 shows the worst-case forward current variations within the LED array when the array is constructed using LED emitters from the same forward voltage category. The worst-case calculations assume that the LED array consists of 16 HPWT-xH00 emitters constructed using four “minimum” LED emitters, four “maximum” LED emitters, and eight “typical” LED emitters. Then each paralleled grouping consists of one “max,” one “min,” and two “typical” LED emitters. The typical calculations assume that the LED array consists of 16 HPWT-xH00 emitters constructed using two “minimum” LED emitters, two “maximum” LED emitters, and twelve “typical” LED emitters. Then two of the paralleled groupings consist of one “max,” one “min,” and two “typical” LED emitters, and the other two paralleled groupings consist of four “typical” LED emitters. Lumileds Lighting recommends a minimum forward current of 35 mA (70 mA for the SnapLED 150), for the “paralleled-string” circuit in Figure 3.1b or the “cross-connected parallel-string” circuit shown in Figure 3.1c. At drive currents less than 35 mA (70 mA for SnapLED 150), the “worst-case” forward current variations between adjacent LED emitters can exceed 2:1. Because of the averaging effects of several series-connected LED emitters, the circuit in Figure 3.1b has somewhat lower typical forward current variations than the circuit shown in Figure 3.1c. Note that the forward current matching can be improved with the addition of a small resistor ( $R_{OPT} > R_S$ ) in series with each string for the circuit shown in Figure 3.1b or “rung” for the circuit shown in Figure 3.1c. For these circuits, it is important to use

SuperFlux LED emitters from only one forward voltage category within the same LED array.

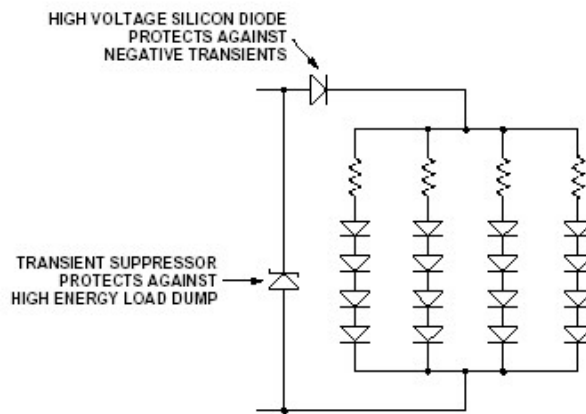

**Figure 3.6 Typical EMC Transient Protection Circuits for LED Signal Lamps.**

LED emitters are susceptible to permanent damage due to high voltage automotive EMC transients. The addition of a high-voltage silicon diode in series with the LED array can effectively protect the array from high-voltage negative transients. The LED array can be protected from positive “Load Dump” transients with the addition of a transient suppressor connected in parallel with the LED array. Figure 3.6 shows the addition of EMC protection circuitry to the LED array. EMC transient protection is covered in more detail in the following section “EMC Transient Protection.”

Some applications require the LED array to operate at two levels of luminous intensity (i.e. a rear Stop/ Tail signal). Generally, it is desirable that the LED emitters should appear matched at both drive conditions. SuperFlux and SnapLED 70 emitters are categorized for luminous flux at 70 mA (150 mA for the SnapLED 150). As shown in the section “Electrical, Optical, and Thermal Characteristics of LED Emitters,” the light output matching for random combinations of LED emitters gets progressively worse at lower

forward currents. For SuperFlux and SnapLED emitters, the light output varies by a factor of 2:1 at a forward current of 20 mA (40 mA for the SnapLED 150). Thus, even if all of the LED emitters are driven at the same forward current, there would likely be unacceptable light output matching if the Tail signal is driven at a low DC forward current.

For best matching, it is recommended that a pulse width modulation (PWM) circuit be designed to operate the signal lamp at

reduced luminous intensity. The Stop signal might operate the LED array at a high DC forward current. Then for the Tail signal, the array would be operated at the same peak forward current with a low duty cycle (ratio of “on” time to “on” plus “off” time). This approach provides light output matching under both levels of luminous intensity. A recommended PWM circuit is shown in the section “Special Considerations for Dual Luminous Intensity Operation.”

# Theory

## Overview of Electrical, Optical, and Thermal Characteristics of an LED Emitter

In order to properly design an LED signal light, it is important to have a basic understanding of the electrical, optical, and thermal characteristics of an LED emitter.

The typical forward current ( $I_F$ ) versus forward voltage ( $V_F$ ) characteristic for an AlInGaP LED emitter under positive (forward) bias is shown in Figure 3.7. On a linear scale of forward current versus forward voltage, negligible current flows until a threshold voltage, also known as the turn-on voltage ( $V_D$ ), is exceeded. Above this voltage, the current increases proportionally to

the incremental forward voltage. Although this graph has been used traditionally to describe the forward characteristics of a diode, in reality LED emitters are best thought of as current controlled devices, not voltage controlled devices. For an LED emitter, the optical properties are best described as a function of current, not a function of voltage. In addition, operation of the LED emitter at a constant current gives the best control of light output. In contrast, operation of the LED emitter at a constant voltage allows a larger variation in forward current and light output from device to device.

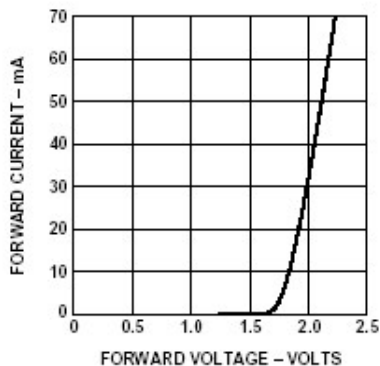

Figure 3.7 Typical Forward Current versus Forward Voltage for HPWA-xHOO LET Emitter (Linear Scale).

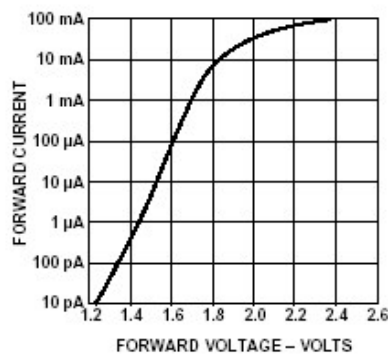

Figure 3.8 Typical Forward Current versus Forward Voltage for HPWA-xHOO LED Emitter (Semi-Long Scale.)

The low-current forward characteristics of the same AlInGaP LED emitter are shown in Figure 3.8. This graph shows the forward voltage versus the log of forward current. Note that a small current flows through the emitter even at low forward voltages below the turn-on voltage shown in Figure 3.7. Due to the high optical efficiency of AlInGaP material, a perceptible amount of light is generated from the LED emitters at forward currents as low as 10  $\mu\text{A}$ . Thus the inadvertent operation at low forward currents can cause “ghosting” within an “off” LED signal light.

The forward voltage of an AlInGaP LED emitter changes by about  $-2$  mV per  $^{\circ}\text{C}$  over temperature. Thus, the forward voltage at a given current is slightly lower at elevated temperatures and slightly higher at colder temperatures.

The reverse characteristics of an AlInGaP LED emitter are shown in Figure 3.9. Note that a negligible amount of reverse current ( $< 1$   $\mu\text{A}$ ) flows through the LED until the reverse breakdown voltage is reached. The reverse current increases quickly at voltages higher than the reverse breakdown voltage (defined as the voltage across the LED at which the reverse current reaches 100  $\mu\text{A}$ ). The reverse breakdown voltage for AlInGaP LED emitters is typically in the range of 20 V. However, it can be as low as 10 V for the HPWA-xx00 and

HPWT-xx00 emitters. Operation of the LED emitter in the reverse current region is not recommended. Reverse currents in excess of 50  $\mu\text{A}$  can cause permanent damage to the LED junction, as discussed later in the section titled “Electrical Transients.” The reverse breakdown voltage is essentially constant over the  $-40^{\circ}\text{C}$  to  $100^{\circ}\text{C}$  temperature range.

The change in luminous flux ( $F_v$ ) as a function of forward current ( $I_f$ ) of an AlInGaP LED emitter is shown in Figure 3.10. Note that the change in luminous flux is roughly proportional to the change in forward current. At forward currents over 20 mA, the luminous flux increases at a lower rate due to internal heating within the LED emitter. The change in luminous flux due to a change in forward current ( $\Delta F_v / \Delta I_f$ ) varies somewhat from unit to unit. Figure 3.11 shows the expected range in light output for HPWT-xH00 emitters that were matched at 70 mA. Note that the light output varies by a factor of 2:1 at a 20 mA forward current. Since the SnapLED 150 emitter is matched at 150 mA, then the light output can be expected to vary by a factor of 2:1 at a forward current of 40 mA.

The luminous flux of an AlInGaP LED emitter varies inversely with temperature as shown in Figure 3.12.

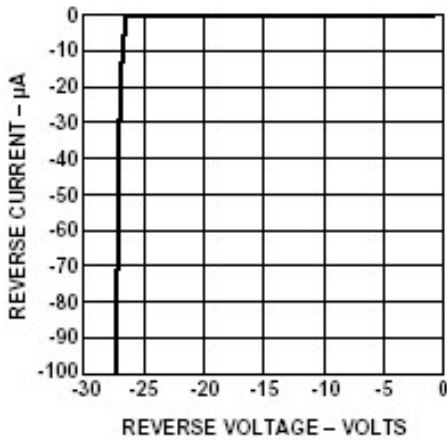

Figure 3.9 Typical Reverse Current versus Reverse Voltage for HPWA-xHOO LED Emitter (Linear Scale).

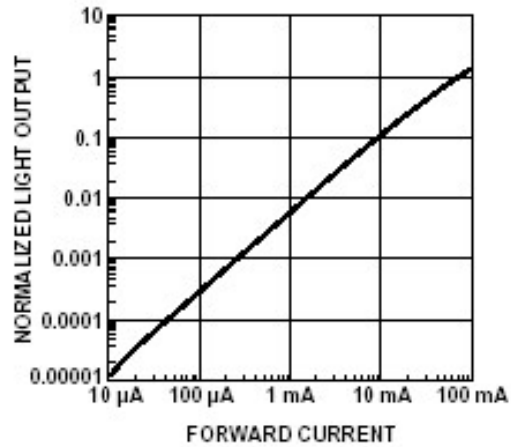

Figure 3.10 Typical Luminous Flux versus Forward Current for HPWA-xHOO LED Emitter (Logarithmic Scale).

At 85°C, the light output will be approximately 50% of the light output at 25°C. At -40°C, the light output will be approximately twice the light output at 25°C. This change is fully reversible.

The peak and dominant wavelength of an AlInGaP LED emitter changes by about 0.1 nm per °C. Thus, the color of the LED shifts slightly toward the red at elevated temperatures.

By now, it should be apparent that a number of the electrical and optical characteristics of an LED emitter vary as a function of ambient and junction temperature. All of these changes in forward voltage, luminous intensity, and peak

and dominant wavelength over temperature are fully reversible when the ambient temperature returns to 25°C.

As might be expected, the junction temperature varies directly as a function of ambient temperature. In addition, the junction temperature of the LED emitter is hotter than the surrounding ambient temperature due to the internal power dissipation ( $I_f V_f$ ) within the LED emitter. Figure 3.13 shows the internal temperature rise,  $T_J - T_A$ , for an LED signal lamp over a range of thermal resistance, as a function of the forward current through the LED emitter.

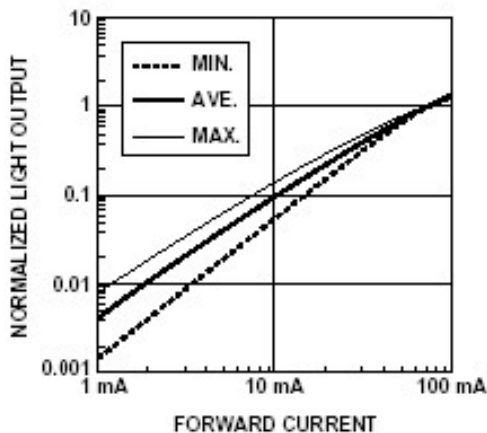

Figure 3.11 Expected Variations in Luminous Flux versus Forward Current for HPWT-xHOO LED Emitters (Logarithmic Scale).

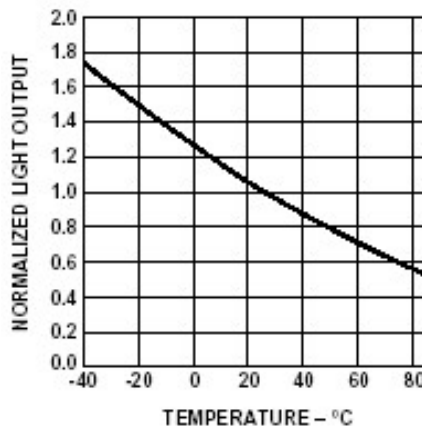

Figure 3.12 Typical Luminous Flux versus Temperature for HPWT-xHOO LED Emitter Driven at 60 mA (Linear Scale).



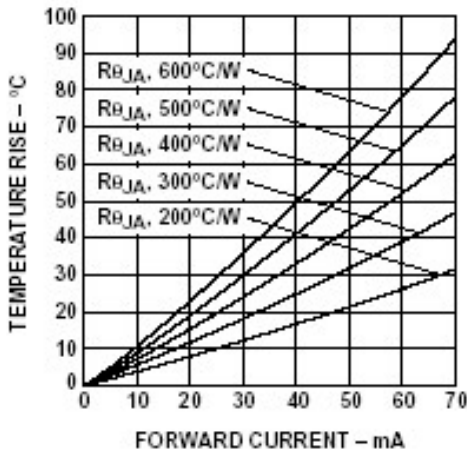

Figure 3.13 Expected Internal Temperature Rise ( $T_J - T_A$ ) for HPWA-xH00 LED Emitter versus Forward Current (Linear Scale).

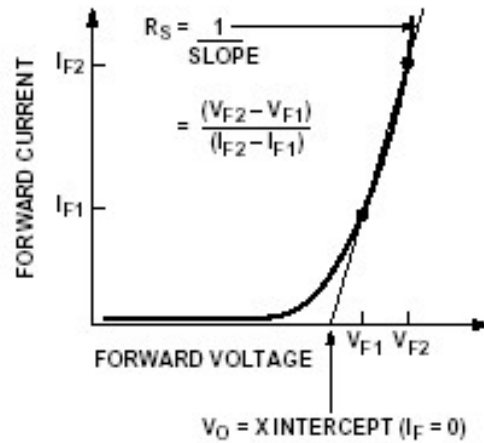

Figure 3.14 Straight-Line Forward Voltage Model for LED Emitter (Linear Scale).

Besides affecting a number of the electrical and optical parameters, the junction temperature and maximum operating current also affect the reliability of the LED emitter. For AlInGaP SuperFlux LED emitters, operation of the emitter near the maximum operating temperature limit and maximum operating current limit can result in a small amount of light degradation over time. In addition, due to the different rates of thermal expansion of the epoxy material used for the emitter package and the metal pins and gold bond-wire within the LED emitter, there are upper and lower limits to the operating and storage temperature ranges for each LED package. Exceeding these limits, especially for hundred's of temperature cycles, can result in premature catastrophic LED emitter failures. These effects are covered in detail in AB20-6, titled "Reliability Considerations for SuperFlux LEDs."

## LED Emitter Modeling

The purpose of modeling is to represent the electrical, optical, and thermal characteristics of a component with equations that allow their

interactions with other electronic components to be expressed mathematically. The process of modeling also requires that mathematical

For these reasons, it is important to understand the thermal properties of the individual LED emitter as well as the thermal properties of all the elements of the LED signal lamp (printed circuit board, case, etc). AB20-4, titled "Thermal Management Considerations for SuperFlux LEDs" discusses the proper thermal design of an LED signal lamp. In this application note, thermal modeling will be covered only in sufficient detail so as to allow proper circuit modeling to maintain the LED junction temperature within the recommended operating temperature limits. This application note will also use thermal modeling to estimate the change in electrical and optical parameters of the LED emitters over temperature and how these effect the operation of the LED signal light. For additional detail on thermal modeling please refer to AB20-4.



expressions be selected that best approximate the actual measured data.

For operation over a restricted range of current, say from 30 mA to 70 mA, the forward current can be modeled with a linear model. As shown in Figure 3.14, the linear model draws a straight line between two points  $(I_{F1}, V_{F1})$  and  $(I_{F2}, V_{F2})$  at two forward currents,  $I_{F1} < I_{F2}$ , to linearize the electrical forward characteristics between these forward currents. The linear model is shown graphically in Figure 3.15 for the forward voltage versus forward current curve shown in Figure 3.7. The equation for the forward current becomes:

$$V_F \cong V_O + R_S I_F \quad (3.3)$$

$$I_F \cong \frac{(V_F - V_O)}{R_S}, \text{ for } V_F \geq V_O$$

Where:

$V_O$  = turn-on voltage, the y-intercept of the straight line ( $I_F = 0$ )

$R_S$  = series resistance, the slope of the straight line

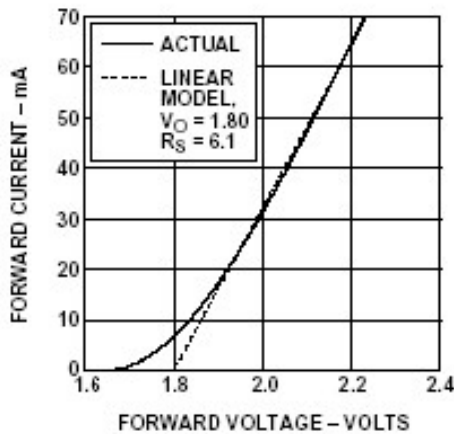

Figure 3.15 Linear Forward Voltage Model for HPWA-xH00 LED Emitter Shown in Figure 7.

Thus, the equations for  $V_O$  and  $R_S$  can be written as:

$$V_O = \frac{(V_{F1} I_{F2} - V_{F2} I_{F1})}{(I_{F2} - I_{F1})} \quad (3.4)$$

$$R_S = \frac{(V_{F2} - V_{F1})}{(I_{F2} - I_{F1})} \quad (3.5)$$

For most applications this linear model can be used to model the forward characteristics of an LED emitter. For best accuracy, the use of the linear model should be restricted to a range of forward currents,  $I_{F2} / I_{F1}$ , less than 4:1. For operation at a lower range of currents, different points  $(I_{F3}, V_{F3})$  and  $(I_{F4}, V_{F4})$  can be selected to bracket the approximate range of operating current. However, it's always important to recognize that the linear model only works for a specified range of forward currents ( $I_{F1}$  to  $I_{F2}$ ) as the accuracy of the linear model degrades quickly outside of this range. It should go without saying that the linear model cannot be used at all for values of  $V_F < V_O$ .

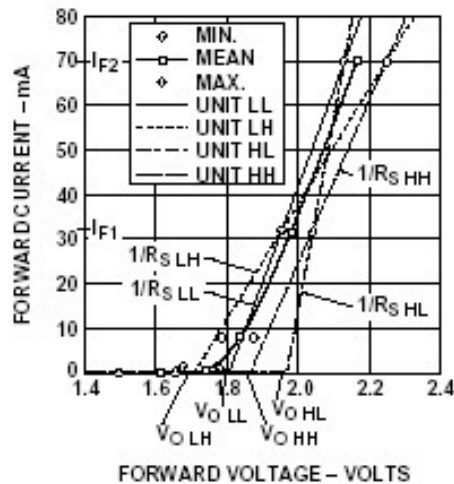

Figure 3.16 Worst-Case Linear Forward Voltage Models for LED Emitters.

Using the nominal forward voltage at the two test currents in Equations #3.4 and #3.5 would generate the typical linear forward voltage model as shown below. The nominal linear forward voltage model ( $V_{O\ nom}$  and  $R_{S\ nom}$ ) is based on the average forward voltages at two test currents,  $I_{F1}$  and  $I_{F2}$ , for a large number of SuperFlux LED emitters from the same forward voltage category.

$$(I_{F1}, V_{F1\ nom}), (I_{F2}, V_{F2\ nom}) \Rightarrow (V_{O\ nom}, R_{S\ nom})$$

Then:

$$V_{F\ nom} = V_{O\ nom} + R_{S\ nom} I_F$$

The values of  $V_F(I_{F1})$  and  $V_F(I_{F2})$  vary for different SuperFlux LED emitters from the same forward voltage category. Statistical forward voltage data for SuperFlux LED emitters is given in AB20-3B. Then, the values of  $V_O$  and  $R_S$  can be calculated using the desired limits (i.e.  $V_{F\ max}$ ,  $V_{F\ min}$ , or  $V_{F\ average} \pm n\sigma$ ). Worst-case circuit analysis is concerned primarily with the highest and lowest forward voltages over the range of  $I_{F1} \leq I_F \leq I_{F2}$ . In most cases, the worst-case range of forward current and forward voltage can be

estimated with two permutations of the linear model as shown in Figure 3.16:

$$V_{F\ min} = V_{O\ LL} + R_{S\ LL} I_F \cong V_{O\ min} + R_{S\ min} I_F$$

$$V_{F\ max} = V_{O\ HH} + R_{S\ HH} I_F \cong V_{O\ max} + R_{S\ max} I_F$$

In order to model the variation in electrical forward characteristics over temperature, another term can be added to the linear model as shown in Equation #3.6. Note that the data shown in AB20-3B represents the forward voltage at 25°C with the units measured cold (i.e.  $T_J = 25^\circ\text{C}$ ). Thus, the thermally stabilized forward voltage at 25°C will be slightly lower than the values shown in AB20-3B.

(3.6)

$$V_F \cong V_O + R_S I_F + (\Delta V_F / \Delta T) (T_J - 25^\circ\text{C})$$

Where:

$T_J$  = junction temperature, °C

$\Delta V_F / \Delta$  = change in  $V_F$  due to temperature,  
 $\cong -2\text{mV}^\circ\text{C}$

$V_O, R_S$  = measured at a junction temperature of 25°C

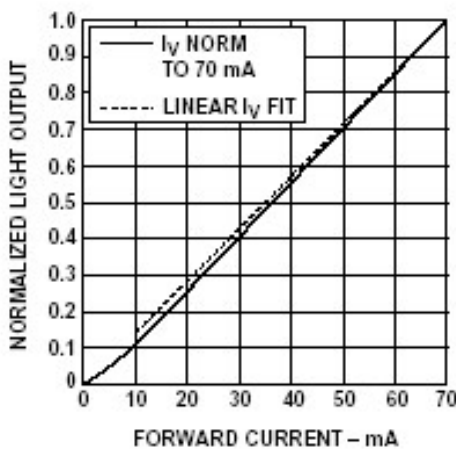

Figure 3.17 Linear Model ( $m = 1$ ) for Luminous Flux versus Forward Current for HPWA-xHOO LED Emitter Shown in Figure 3.10.

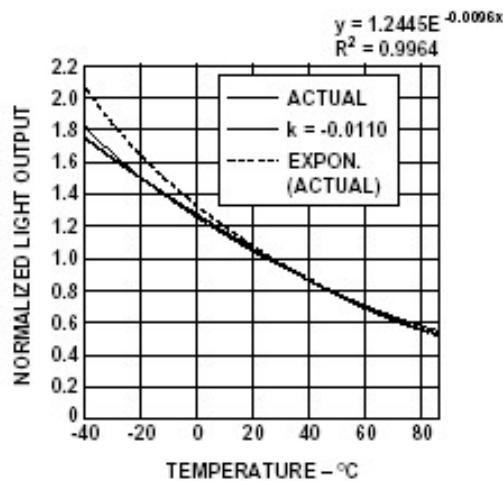

Figure 3.18 Exponential Model ( $k = -0.0110$ ) and Exponential Curve Fit ( $k = -0.0096$ ) for Luminous Flux versus Temperature for HPWA-xHOO LED Emitter Shown in Figure 3.12.

In general, the luminous flux output of LED emitters varies as a function of the forward current. Ignoring the effect of heating, the relationship between luminous flux and forward current can be modeled with the following equation:

$$F_V(I_F, T_J = 25^\circ\text{C}) @ F_V(I_{F\text{ TEST}}, T_J = 25^\circ\text{C}) [I_F / I_{F\text{ TEST}}]^m \quad (3.7)$$

Where:

$F_V(I_F, T_J = 25^\circ\text{C})$  = Luminous flux at forward current,  $I_F$ , ignoring heating

$F_V(I_{F\text{ TEST}}, T_J = 25^\circ\text{C})$  = Luminous flux at test current,  $I_{F\text{ TEST}}$ , ignoring heating

$I_F$  = forward current

$I_{F\text{ TEST}}$  = forward current at data sheet test conditions

$m$  = linearity factor,  $1 \leq m \leq 2$

At forward currents less than 10 mA,  $m \approx 1.3$  for AlInGaP LED emitters. At forward currents over 30 mA, the linearity factor,  $m \approx 1.0$  for AlInGaP LED emitters. Figure 3.17 shows how the modeled data for  $F_V$  versus  $I_F$  compares to the actual data shown in Figure 3.10.

For operation at forward currents over 30 mA, Equation #3.7 can be simplified into a simple linear equation:

$$F_V(I_F, T_J = 25^\circ\text{C}) @ F_V(I_{F\text{ TEST}}, T_J = 25^\circ\text{C}) [I_F / I_{F\text{ TEST}}]$$

The luminous flux varies exponentially with temperature. The simplest model is shown below:

$$F_V(T_J) @ F_V(T_J = 25^\circ\text{C}) \exp [k(T_J - 25^\circ\text{C})] \quad (3.8)$$

Where:

$F_V(T_J)$  = luminous flux at forward current  $I_F$  at junction temperature,  $T_J$

$F_V(T_J = 25^\circ\text{C})$  = luminous flux at  $25^\circ\text{C}$ , without heating

$k$  = thermal coefficient,  $k \approx -0.01$

Over the automotive operating temperature range of  $-40^\circ\text{C}$  to  $85^\circ\text{C}$ , this model matches the actual data within  $\pm 10\%$ . Figure 3.18 shows how the modeled data for  $F_V$  as a function of temperature compares to the actual data shown in Figure 3.12. Note that the value selected for  $k$  was chosen to improve the curve fit at elevated temperatures than at temperatures below  $25^\circ\text{C}$ . Typical values of  $k$  for AlInGaP and TS AlGaAs SuperFlux LED emitters are shown in Table 3.1.

Thermal resistance is a measurement of the temperature rise within the LED signal lamp caused by internal power dissipation as well as other sources of heat in close proximity to the LED (i.e. bulbs, resistors, drive transistors, etc). For a detailed discussion of thermal resistance, please refer to AB20-4. The units of thermal resistance are  $^\circ\text{C}/\text{W}$ . For the same power dissipation, the LED signal lamp with a higher thermal resistance would have a larger internal temperature rise. The basic thermal modeling equation is shown below:

$$T_J @ T_A + R_{qJA} P_D \quad (3.9)$$

Where:

$T_J$  = internal junction temperature within the LED emitter,  $^\circ\text{C}$

$T_A$  = ambient temperature surrounding the LED signal lamp,  $^\circ\text{C}$

$R_{qJA}$  = thermal resistance, junction to ambient,  $^\circ\text{C}/\text{W}$

$P_D$  = internal power dissipation within the LED  
 LED signal lamps typically use several LED emitters. Each LED has a slightly different thermal resistance, based on the proximity of other heat sources (e.g. adjacent LED emitters, resistors, power transistors, bulbs, etc) and printed circuit board layout. Generally, the thermal resistance value used for thermal modeling is the highest thermal resistance,  $Rq_{JA}$ , of any of the LED emitters within the LED lamp assembly. Experience has shown that the LED emitter with the highest thermal resistance is usually either one of the emitters in the center of the LED lamp assembly for an x-y arrangement of emitters, the middle emitter in a single row of emitters, or one of the emitters adjacent to other heat sources (e.g. resistors, power transistors, bulbs, etc).

The thermal modeling equation can be further broken down by separately considering the thermal resistance of each of the elements of the LED signal lamp as shown below:

$$\begin{aligned} T_J @ T_A + (Rq_{JP} + Rq_{PA}) P_D \\ T_P @ T_A + (Rq_{PA}) P_D \end{aligned} \quad (3.10)$$

emitter ( $I_F V_F$ ), W

Where:

$Rq_{JP}$  = thermal resistance, junction to pin (LED emitter package), °C/W

$Rq_{PA}$  = thermal resistance pin to air (printed circuit and case), °C/W

$T_P$  = LED cathode pin temperature on underside of printed circuit board, °C

These equations are especially useful since the thermal resistance junction to pin,  $Rq_{JP}$ , is specified on the product data sheet and the LED pin temperature can be measured directly by attaching a thermocouple on the cathode lead of the LED emitter on the underside of the printed circuit board. Thus the junction temperature can be estimated based on a measurement of the pin temperature of the LED emitter (please refer to AB20-4).

Usually thermal resistance measurements are done at thermal equilibrium. For an LED signal lamp, thermal equilibrium usually occurs after 30 minutes of continuous operation. In some cases, it is important to calculate the junction temperature under a transient condition (e.g. 2 minutes at 24 V).

**Table 3.1**

VALUES OF $k$ FOR ALINGAP SUPERFLUX LED EMITTERS			
FAMILY	LED MATERIAL	DOMINANT WAVELENGTH	COEFFICIENT OF $\Phi_V, (T), k$
HPWA-xHOO	AS AlInGaP	618 nm	-0.0106
HPWA-xLOO	AS AlInGaP	592 nm	-0.0175
HPWT-xDOO	TS AlInGaP	630 nm	-0.0106
HPWT-xHOO	TS AlInGaP	620 nm	-0.0106
HPWT-xLOO	TS AlInGaP	594 nm	-0.0175

This can be done by further subdividing the thermal modeling equation as shown below:

$$T_J \cong T_A + (R\theta_{JLF} + R\theta_{LFP} + R\theta_{PA}) P_D \quad (3.11)$$

Where:

$R\theta_{JLF}$  = thermal resistance, junction to lead frame (LED die), °C/W

$R\theta_{LFP}$  = thermal resistance, lead frame to pin (LED package excluding die), °C/W

Please note that each thermal resistance ( $R\theta_{JLF}$ ,  $R\theta_{LFP}$ , and  $R\theta_{PA}$ ) has a different heating time constant. The time constant associated with heating of the LED die is in the order of one millisecond. The time constant associated with the heating of the LED emitter package is in the order of one minute. The time constant associated with the heating of the complete LED signal lamp is in the order of 10 to 30 minutes. Thus, for a transient heating condition, the LED

die will be the first element of the model to heat-up, followed by the LED emitter package, and then the rest of the LED signal light.

This section discussed the key concepts of modeling the electrical, optical, and thermal performance of LED signal lights. Equations #3.3 and #3.7 can be used to model the operation of an LED emitter at room temperature, ignoring the effects of self-heating. Equations #3.6, #3.7, #3.8, and #3.9 can be used together to model the effects of self-heating of an LED emitter at room temperature as well as to model the operation of an LED emitter over temperature. Equations #3.10 and #3.11 show the various components of the overall thermal resistance,  $Rq_{JA}$ , which can be useful in the thermal modeling of an LED signal lamp assembly and the thermal modeling of transient power conditions.

# Applications

## Resistive Current Limiting

As discussed previously in the section “Key Concepts for Electrical Design of LED Signal Lamps,” the choice of the number of LED emitters per series-string has a large effect on the forward current regulation and the overall electrical power consumption of the LED signal lamp. Most 12V designs commonly use either three or four emitters per series-string, which is a good balance of current regulation and electrical power consumption. Then, the choice of circuit topology (Figure 3.1 circuits) and the design current determine the variation in forward currents for the LED emitters in the array. Finally, protection circuitry can be added,

if the LED signal light will be subjected to automotive EMC transients.

For a resistive current-limited circuit the electrical design process consists mainly of picking the proper value(s) for the current limiting resistor(s). The key principles of worst-case design are shown in Figure 3.19. The figure shows the forward current through one LED string of four emitters as a function of input voltage. The equation for this graph (Equation #3.12) is equal to Equation #3.2 solved for  $I_F$ :

Equation #3.2, from “Key Concepts for Electrical Design of LED Signal Lamps.”

$$R = \frac{V_{IN} - yV_O - V_D}{xI_F} - \frac{y}{x}R_S$$

Where:

$R$  = external current limiting resistor

$V_{IN}$  = input voltage applied to the circuit

$V_D$  = voltage drop across optional reverse transient EMC protection diode

$I_F$  = design forward current through the circuit

$V_O$  = turn-on voltage of the linear forward voltage model

$R_S$  = series resistance of the linear forward voltage model

$y$  = number of series connected LED emitters

$x$  = number of paralleled strings used with external current limiting resistor

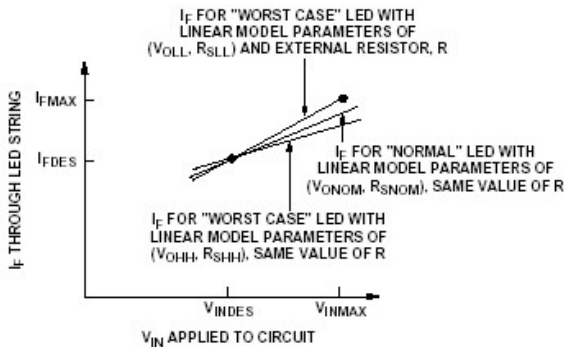

Figure 3.19 Worst-Case Variations in Forward Current Through Several LED Strings as a Function of the Applied Voltage.

$$I_F = \frac{V_{IN} - yV_O - V_D}{xR + yR_S} \quad (3.12)$$

Note, for the example shown in this section:  $x = 1$  and  $y = 4$ .

Figure 3.19 shows how the variation in forward voltage of the LED emitters affects the forward current through the string. These curves are generated by substituting the worst-case linear forward voltage model parameters  $[(V_{O,NOM}, R_{S,NOM}), (V_{O,LL}, R_{S,LL}), \text{ or } (V_{O,HH}, R_{S,HH})]$  into Equation

#3.12, for the same value of external current limiting resistor,  $R$ .

The maximum forward current through the LED string is determined by the effects of thermal resistance of the LED signal lamp,  $R\theta_{JA}$ , and maximum ambient temperature,  $T_{A,MAX}$ , as shown in Figure 4 of the SuperFlux LED Data Sheet.

So, the worst-case design procedure is to determine the maximum forward current,  $I_{F,MAX}$ , based on parameters  $R\theta_{JA}$  and  $T_{A,MAX}$  from Figure 4 of the SuperFlux LED Data Sheet. Then the value of the external resistor,  $R$ , is determined with Equation #3.2, using values of  $I_{F,MAX}$ ,  $V_{IN,MAX}$ , and LED linear model parameters  $(V_{O,LL}, R_{S,LL})$ . The nominal design current,  $I_{F,DES}$ , which occurs at the design voltage,  $V_{IN,DES}$ , can be calculated with Equation #3.12 using values of  $V_{IN,DES}$ ,  $R$ , and LED emitters with a typical forward voltage [i.e. with linear model parameters  $(V_{O,NOM}, R_{S,NOM})$ ].

In practice, the LED signal lamp needs to be designed to accommodate a range of forward voltage categories and luminous flux categories. In most cases, the overall goal is to design an LED signal lamp with a fixed light output. For LED emitters from the same luminous flux category, this can be accomplished by calculating different values of external resistor,  $R$ , using Equation #3.2, with the same design current and voltage,  $I_{F,DES}$  and  $V_{IN,DES}$ , and using the nominal forward voltage models  $(V_{O,NOM}, R_{S,NOM})$  for each forward voltage category.

For LED emitters with higher luminous flux categories, the design current would be reduced to keep the light output constant. First, the minimum luminous flux would be calculated for the lowest expected luminous flux category at

the nominal design current. Then Figure 3 from the SuperFlux LED Data Sheet could be used to calculate the other design currents for higher luminous flux categories. Then values of external resistor,  $R$ , can be calculated with Equation #3.2 at the reduced design current using the appropriate nominal forward voltage models for each forward voltage category.

After all of these “ideal” values of  $R$  are computed, the designer would need to choose the closest standard resistor values. In many cases, the designer can use the same resistor value for multiple LED emitter categories provided that the maximum forward current is not exceeded under worst-case conditions.

Experience has shown that the worst-case design occurs with the lowest expected luminous flux category and the highest forward voltage category. Thus, the lowest value of external resistor,  $R$ , and the highest design current,  $I_{FDES}$ , would be determined for this particular category combination. For LED emitters with the lowest expected luminous flux category and lower forward voltage categories, Equation #3.2 will generate higher values of  $R$ . For LED emitters with higher luminous flux categories, the values of  $R$  will be even larger since the design current is reduced.

The assumptions used for maximum ambient temperature,  $Rq_{JA}$ , maximum steady-state input voltage, and the worst-case SuperFlux LED categories (minimum expected luminous flux and maximum expected forward voltage) have a large effect on the nominal design current and thus the luminous flux output. Thus these parameters have a large effect on the number of LED emitters needed for a given signal lamp

design. Lumileds Lighting recommends that the designer use realistic assumptions for these parameters. It is very easy to overly guard-band these assumptions, which results in an excessive estimate of the number of LED emitters needed.

The luminous efficiency of AllnGaP technology has significantly improved over the past few years. Please consult with your Lumileds Lighting or Agilent Technologies Field Sales Engineer for the recommended minimum luminous flux categories of SuperFlux LED emitters for given future production dates.

Many LED signal lamp requirements also include operation at higher voltages for a limited duration (i.e. 24 volts for two minutes). In analyzing the performance of an LED signal lamp under these conditions, it is important to analyze the transient heating effects. Under these conditions the LED emitters don't reach thermal equilibrium so the junction temperatures are lower than indicated by Equation #3.9. Equation #3.11 can be used to estimate the maximum junction temperature using the appropriate time constants for  $Rq_{JLF}$ ,  $Rq_{LFP}$ , and  $Rq_{PA}$ . In addition, many test specifications allow a different operating temperature for these tests.



## CHMSL Design Example

This worst-case design procedure will be illustrated with an example. Let suppose that an LED array is being designed using 4-LED strings of HPWT-MH00 from luminous flux categories F through L and forward voltage categories 2 through 6. For this example  $R_{qJA} = 350^\circ\text{C/W}$ ,  $T_{A\text{MAX}} = 70^\circ\text{C}$ ,  $V_{IN\text{MAX}} = 15.0\text{ V}$ , and  $V_{IN\text{DES}} = 12.8\text{ V}$ . In addition, a silicon diode with a forward voltage of  $0.8\text{ V}$  is connected in series with the circuit in order to provide protection against negative EMC transients. Then, the design steps are shown below:

### 1. Determine $I_{F\text{MAX}}$ :

The maximum allowable DC forward current through the SuperFlux LED emitters is determined from the maximum ambient temperature,  $T_{A\text{MAX}}$ , estimated overall thermal resistance,  $R_{qJA}$ , of the LED signal lamp, and Figure 4 of the Data Sheet.

For  $T_{A\text{MAX}} = 70^\circ\text{C}$ , and  $R_{qJA} = 350^\circ\text{C/W}$ :

Then:  $I_{F\text{MAX}} = 55\text{ mA}$ , from HPWT-MH00 DataSheet, Figure 4

### 2. Determine minimum value of current limiting resistor, $R$ :

The minimum value of  $R$  is determined with Equation #3.2 at the maximum input voltage and maximum forward current from Step 1 for the maximum forward voltage category Super Flux LED to be used in the assembly.

For HPWT-MH00, forward voltage category 6:

$$V_{OLL} = 1.85\text{ V}, R_{SLL} = 14.4\text{ ohm}$$

Then:

$$R = \frac{15 - 4(1.85) - 0.8}{0.055} - 4(14.4) = 66\text{ ohm}$$

### 3. Determine nominal design current, $I_{F\text{DES}}$ :

The nominal forward current through the LED emitters at the design voltage is determined with Equation #3.12. The equation should use the value of  $R$  from the Step 2 at the design voltage and the nominal forward voltage of the SuperFlux LED emitters using the same forward voltage category used in Step 2.

For HPWT-MH00, forward voltage category 6:

$$V_{ONOM} = 2.03\text{ V}, R_{SNOM} = 12.4\text{ ohm}$$

$$\text{Then: } I_{F\text{DES}} = \frac{12.8 - 4(2.03) - 0.8}{66 + 4(12.4)} = 33.6\text{ mA}$$



4. Determine value of external current limiting resistor,  $R$ , for each forward voltage category:

The linear forward voltage models for the other HPWT-MH00 forward voltage categories are shown below:

For SuperFlux LED emitters from lower forward voltage categories, the value of the external resistor,  $R$ , will need to be increased (using Equation #3.2) in order to maintain the same nominal forward current.

HPWT-MH00	VOLTAGE CATEGORY 2	VOLTAGE CATEGORY 3	VOLTAGE CATEGORY 4	VOLTAGE CATEGORY 5	VOLTAGE CATEGORY 6
$V_{O\ NOM} =$	1.87 V	1.91 V	1.94 V	1.96 V	2.03 V
$R_{S\ NOM} =$	8.2 OHM	9.2 OHM	10.5 OHM	11.6 OHM	12.4 OHM

For  $V_{IN\ DES} = 12.8\ V$ ,  $V_D = 0.8\ V$ ,  $I_{F\ DES} = 33.6\ mA$ ,  $x = 1$ ,  $y = 4$ :

HPWT-MH00	VOLTAGE CATEGORY 2	VOLTAGE CATEGORY 3	VOLTAGE CATEGORY 4	VOLTAGE CATEGORY 5	VOLTAGE CATEGORY 6
$R =$	102 OHM	93 OHM	84 OHM	77 OHM	66 OHM

5. Determine minimum thermally stabilized luminous flux:

Design currents for SuperFlux LED emitters at higher luminous flux categories can be determined using Figure 3 from the SuperFlux LED Data Sheet. This can be done by computing a new “relative luminous flux” equal to the desired luminous flux divided by the minimum luminous flux category bin limit and then reading a new value of forward current from Figure 3.

The thermally stabilized luminous flux of the SuperFlux LED emitters from the lowest expected luminous flux category can be determined using Figure 3 from the SuperFlux LED Data Sheet.

For HPWT-MH00, luminous flux category F (3.0 lm minimum) and  $I_{F\ DES} = 33.6\ mA$ :

The same minimum luminous flux obtained from a HPWT-MH00 luminous flux category F (3.0 lm) driven at 33.6 mA can be obtained from a HPWT-MH00 from the following luminous flux categories when driven at the specified forward current:

Then:  $\Phi_{V\ MIN} = (3.0)(0.54) = 1.62\ lm$ , (i.e. “relative luminous flux” = 0.54) from HPWT-MH00 Data Sheet, Figure 3

6. Determine design currents for brighter SuperFlux LED emitters:

From Figure 3, HPWT-MH00 Data Sheet:

LUMINOUS FLUX CATEGORY	F	G	H	J	L
MINIMUM LUMINOUS FLUX	3.0 LM	3.5 LM	4.0 LM	5.0 LM	6.0 LM
DESIRED "RELATIVE LUMINOUS FLUX"	0.54	0.46	0.41	0.32	0.27
DESIGN CURRENT, FROM FIGURE 3	33.6 mA	29 mA	25 mA	19 mA	15 mA

Note: Due to the variations in forward voltage at low currents, there is a practical limit to the use of higher and higher luminous flux categories at correspondingly lower dc drive currents. For the series string circuit shown in Figure 3.1a, at drive currents less than 20 mA, the "worst-case" ratio of forward currents between two strings of LED emitters can vary by over 2:1. As shown by this example, in order to achieve the same light output for all CHMSL arrays, designs using HPWT-MH00 emitters from luminous flux categories J and L would require drive currents less than 20 mA. Thus, the designer needs to establish whether it is better to limit the forward current to 20 mA and allow the light output to increase for these brighter luminous flux

categories, or to accept possible visible light output mismatch within the array.

7. Determine values of  $R$  for expected luminous flux and forward voltage categories:

Values of  $R$  can be determined (using Equation #3.2) for each SuperFlux LED emitter forward voltage category and luminous flux category at the appropriate design current as calculated in Step 6.

Note: Since the design current of the HPWT-MH00 LED array is less than 32 mA for designs using luminous flux bins G through K, a "low current" linear forward voltage model ( $8 \text{ mA} \leq I_F \leq 32 \text{ mA}$ ) was used. This model is shown below:

HPWT-MH00	VOLTAGE CATEGORY 2	VOLTAGE CATEGORY 3	VOLTAGE CATEGORY 4	VOLTAGE CATEGORY 5	VOLTAGE CATEGORY 6
$V_{O \text{ NOM}} =$	1.80 V	1.83 V	1.85 V	1.88 V	1.94 V
$R_{S \text{ NOM}} =$	10.4 OHM	11.7 OHM	13.2 OHM	14.3 OHM	15.1 OHM

For  $V_{IN \text{ DES}} = 12.8 \text{ V}$ ,  $V_D = 0.8 \text{ V}$ ,  $I_{F \text{ DES}}$  from Step 6,  $V_{O \text{ NOM}}$ ,  $R_{S \text{ NOM}}$ ,  $x = 1$ ,  $y = 4$ :

HPWT-MH00	DESIGN CURRENT	VOLTAGE CATEGORY 2	VOLTAGE CATEGORY 3	VOLTAGE CATEGORY 4	VOLTAGE CATEGORY 5	VOLTAGE CATEGORY 6
FLUX, F	33.6 mA	102 OHM	93 OHM	84 OHM	77 OHM	66 OHM
FLUX, G	29 mA	124 OHM	115 OHM	106 OHM	97 OHM	86 OHM
FLUX, H	25 mA	151 OHM	140 OHM	131 OHM	122 OHM	109 OHM
FLUX, J	19 mA <sup>[1]</sup>	212 OHM	199 OHM	189 OHM	179 OHM	162 OHM
FLUX, K	15 mA <sup>[1]</sup>	279 OHM	265 OHM	253 OHM	242 OHM	222 OHM

Note 1: Operation at dc drive currents below 20 mA can cause noticeable light output differences within the LED array.

8. Select “standard” resistor values:

Standard 5% Tolerance Resistors

HPWT-MHOO	DESIGN CURRENT	VOLTAGE CATEGORY 2	VOLTAGE CATEGORY 3	VOLTAGE CATEGORY 4	VOLTAGE CATEGORY 5	VOLTAGE CATEGORY 6
FLUX, F	33.6 mA	100 OHM	91 OHM	82 OHM	75 OHM	68 OHM
FLUX, G	29 mA	120 OHM	110 OHM	110 OHM	100 OHM	91 OHM
FLUX, H	25 mA	150 OHM	150 OHM	130 OHM	120 OHM	110 OHM
FLUX, J	19 mA <sup>(1)</sup>	220 OHM	200 OHM	180 OHM	180 OHM	160 OHM
FLUX, K	15 mA <sup>(1)</sup>	270 OHM	270 OHM	240 OHM	240 OHM	220 OHM

**Note 1:** Operation at dc drive currents below 20 mA can cause noticeable light output differences within the LED array.

9. Group “standard” adjacent cells in resistor matrix in Step 8 as desired:

Standard 5% Tolerance Resistors

HPWT-MHOO	DESIGN CURRENT	VOLTAGE CATEGORY 2	VOLTAGE CATEGORY 3	VOLTAGE CATEGORY 4	VOLTAGE CATEGORY 5	VOLTAGE CATEGORY 6
FLUX, F	33.6 mA	100 OHM		82 OHM		
FLUX, G	29 mA	120 OHM		110 OHM		
FLUX, H	25 mA	150 OHM		130 OHM		
FLUX, J	19 mA <sup>(1)</sup>	220 OHM		180 OHM		
FLUX, K	15 mA <sup>(1)</sup>	270 OHM		240 OHM		

**Note 1:** Operation at dc drive currents below 20 mA can cause noticeable light output differences within the LED array.

10. Perform “worst-case” analysis to ensure that maximum forward current is not exceeded over temperature.

varies slightly over temperature as shown in Equation #3.6. This thermal effect can be included in Equation #3.12 as shown below:

Calculate maximum forward current (using Equation #3.12) at “worst-case” conditions— i.e. maximum input voltage, minimum resistor values, and minimum forward voltages for each SuperFlux LED emitter forward voltage category. The forward voltage of LED emitters

$$I_{FMAX} = \frac{V_{INMAX} - y[V_{OLL} + (\Delta V_F / \Delta T)(T_J - 25^\circ C)] - V_D}{xR_{MIN} + yR_{SLL}}$$

## EMC Transient Protection

Circuits designed for the automotive electrical environment must be able to operate over a wide range of input voltages and be able to

tolerate a number of different types of electrical transients. These worst-case voltage ranges and electrical transients have been characterized and

are defined in different automotive specifications such as:

**DIN 40839 Part 1**

“Electromagnetic Compatibility (EMC) in Motor Vehicles; interferences conducted along supply lines in 12 V onboard system”

**DIN 40839 Part 2**

“Electromagnetic Compatibility (EMC) in Motor Vehicles; interferences conducted along supply lines in 24 V onboard system”

**ISO 7647-1**

“Road Vehicles—Electrical Disturbance Caused by Conduction and Coupling; passenger cars and light commercial vehicles with nominal 12 V supply voltage”

**ISO 7647-2**

“Road Vehicles—Electrical Disturbance Caused by Conduction and Coupling; commercial vehicles with nominal 24 V supply voltage”

**SAE J1113**

“Electromagnetic Susceptibility Measurement Procedures for Vehicle Components (except Aircraft)”

**SAE J1211**

“Recommended Environmental Practices for Electronic Equipment Design”

**SAE J1812**

“Function Performance Status for EMC Susceptibility Testing of Automotive Electronic and Electrical Devices”

These specifications define several electrical transient pulses that occur when inductive loads

are turned off within the vehicle, switching transients of electronic circuitry, alternator field decay, or a fully discharged battery being disconnected while the alternator is operating at rated load. These transients consist of both positive and negative pulses with different amplitudes and decay times.

Limited reliability testing has been done with AlInGaP LED emitters connected in typical LED signal lamp configurations.

High-voltage negative transients in excess of the reverse breakdown voltage can permanently damage AlInGaP LED emitters. Sufficient energy can be dissipated within the AlInGaP LED die to cause localized damage to the p-n diode structure. This damage can result in reduced breakdown voltages, and degraded low-current performance. Under extreme conditions, high voltage negative transients can even destroy the p-n junction, resulting in a short between anode and cathode.

Adding a high-voltage silicon diode in series with the LED signal light array, such as previously shown in Figure 3.6, can prevent potential damage to high voltage negative transients. The silicon diode should have a higher reverse breakdown voltage than the amplitude of the worst-case negative transient, which can be as large as -300 V (-600 V for heavy trucks). Table 3.2 shows several recommended silicon diodes for different LED signal lamp applications.

In addition, high-voltage positive transients can permanently damage AlInGaP LED emitters. Sufficient energy can be dissipated within the AlInGaP LED die to cause permanent damage to the p-n diode structure and cause epoxy

delamination between the LED and surrounding epoxy. Under extreme conditions, the epoxy surrounding the LED die can be charred and the gold bond wire and LED die can be destroyed, resulting in an open circuit. The AlInGaP LED die can tolerate non-recurring peak current transients of several hundred milliamperes for short time periods ( $t \ll 1$  ms) with minimal permanent effects. However, longer transients can cause sufficient localized heating to cause the various effects listed earlier. The “Load Dump” transient pulse can be especially damaging since the pulse duration can be up to 400 ms.

The effects of “Load Dump” transients can be minimized by putting a surge-suppressor or silicon transient suppressor in parallel with the LED array as previously shown in Figure 3.6. Note that the breakdown voltage of the transient suppressor, as well as the current-

limiting properties of the LED drive circuit, determine the maximum peak current through the LED array. For best results, the breakdown voltage of the transient suppressor should fall within the following range:

$$24 V < V_{BR} < 45 V$$

Note that the 24 V restriction is determined by the “Jump Start” voltage condition. The 45 V restriction is determined by the ability of the LED array to withstand the peak current imposed by the transient voltage. Since the 45 V limit depends on the circuit topography of the LED array and the maximum “Load Dump” transient pulse duration, this voltage limit should be established by reliability testing.

**Table 3.2**

SILICON DIODES FOR EMC NEGATIVE TRANSIENT PROTECTION			
DIODE PART NUMBER	MAXIMUM CONTINUOUS FORWARD CURRENT, $I_o$	REVERSE BREAKDOWN VOLTAGE, $V_{RRM}$	APPLICATIONS
1N4005	1.0 A	600 V	CHMSL
1N5396	1.5 A	600 V	REAR COMBINATION LAMP
1N5406	3.0 A	600 V	REAR COMBINATION LAMP, & FRONT TURN SIGNAL

## Special Considerations for Dual Luminous Intensity Operation

Some applications, such as a Stop/Tail signal lamp require two discrete levels of light output. These applications require some additional design considerations. In most cases, the ratios in light output at the two signal conditions are determined by the various signal lamp specifications or regulations. Typical dimming

ratios for Stop/Tail signals are 7:1 to 15:1. Generally, the LED emitters should appear matched in luminous flux at both drive conditions. This implies that the forward currents for the LED emitters in the array should be matched at both drive currents. SuperFlux and SnapLED 70 emitters are categorized for

luminous flux and forward voltage at 70 mA (150 mA for the SnapLED 150). Thus, their matching is best when driven at high forward currents. As discussed in the section “Electrical, Optical, and Thermal Properties of an LED Emitter,” Figure 3.11 shows the expected range in light output for HPWT-xH00 emitters that are matched at 70 mA. Note that the light output varies by approximately 2:1 at a 20 mA forward current. Note that since the SnapLED 150 is matched at 150 mA, then the light output would vary by about 2:1 at 40 mA. Thus, even if a well-controlled constant current circuit drives the LED emitters, the light output matching might be unacceptable for the Tail function if driven by a low DC forward current.

A PWM circuit is recommended for best luminous intensity matching for the Tail function. This circuit could drive the LED array at a high forward current for the Stop function and drive the LED array at the same peak forward current but at a low duty cycle for the Tail function. With this approach, the matching of the LED array will be the same regardless of whether the signal is operating in Stop or Tail mode.

Figure 3.20 shows a PWM Tail circuit. When the input voltage is applied to the Stop pin, the cross-connected paralleled string circuit is operated at a dc forward current determined external resistor,  $R_{STOP}$ . The value for  $R_{STOP}$  can be determined using Equation #3.2. When the input voltage is applied to the Tail pin, the NE555 oscillator is energized. Resistors,  $R_1$  and  $R_2$ , and capacitor,  $C_1$ , determine the frequency and duty cycle of the oscillator. The values shown generate a 2K Hz frequency and a 10% duty cycle (output low). When the output of the NE555 (pin 3) is low, a high-current switching transistor is turned-on, which supplies current to the LED array. External resistor,  $R_{TAIL}$ , determines the peak current of the Tail circuit. The value for  $R_{TAIL}$  can be determined using a similar equation as used previously for  $R_{STOP}$  and including the extra voltage drop across the high-current switching transistor. Thus for the same value of peak forward current,  $R_{TAIL} < R_{STOP}$ . Diodes  $D_1$  and  $D_2$  protect the circuit from negative EMC transients. Zener diode  $D_3$  protects the NE555 from positive EMC transients.

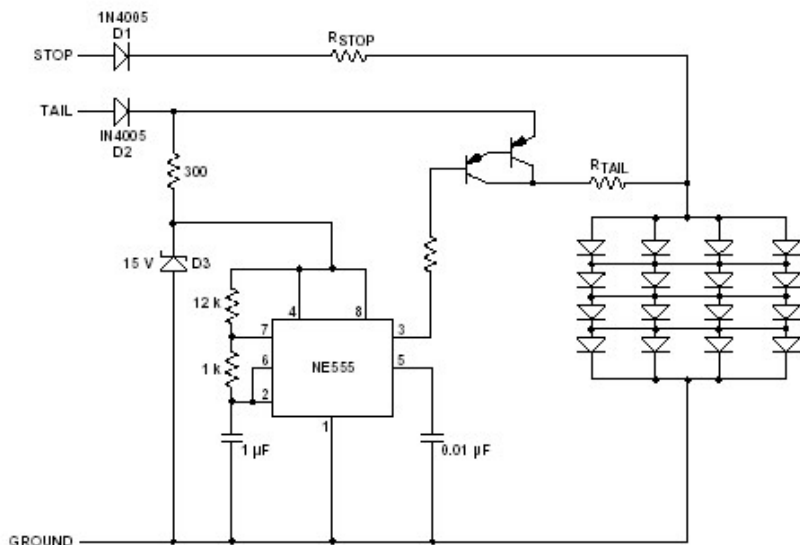

Figure 3.20 Stop/Tail LED Signal Lamp Circuit that Uses a PWM Scheme to Generate the Reduced Light Output of the Tail Signal.

## Current and Voltage Regulator Circuits

---

This section will discuss active circuits that are designed to drive the LED emitter array at a constant voltage or constant current despite input voltage or load variations. These circuits are called voltage or current regulator circuits because they are designed to regulate the input voltage to generate either a fixed output voltage or current.

The use of voltage or current regulation improves the operation of the LED signal lamp. Since the drive current of the LED array remains constant despite variations in the supply voltage, the light output is not affected by input voltage variations. Since the drive current doesn't increase due to over voltage conditions, the LED emitters can be driven at a higher forward current at the design voltage without exceeding the maximum allowable forward current at the maximum input voltage. In addition, if the circuit is located outside of the LED signal lamp case, the voltage or current regulator circuit can improve the thermal properties of the signal lamp by reducing the power consumption within the LED signal lamp.

Block diagrams of typical voltage and current regulator circuits are shown in Figure 3.21. The basic elements of all of these circuits consist of a high gain amplifier and feedback circuit, which vary the dynamic load of a power circuit that is either in series or parallel with the LED emitter array. The regulator circuit modulates the dynamic load so as to provide either a constant voltage or current to the LED emitter array independent of input voltage or load variations (over some specified range). Voltage regulator circuits measure the voltage across the load

and compare the load voltage with a reference voltage. Current regulator circuits usually measure the current through the load by measuring the voltage drop across a “sense” resistor in series with the load. Then the voltage across the sense resistor is compared with a reference voltage.

Since most LED signal lamp designs consist of several LED emitters, they are normally arranged in one or more series-connected strings, such as shown previously in Figure 3.1. While it is possible to use one voltage or current regulator per string, due to cost considerations, most practical designs use a single voltage or current regulator for the entire LED array. Note that when only a single regulator is used for the entire array it is possible to encounter the same type of forward current variations as described earlier in the section “Key Concepts for the Electrical Design of LED Signal Lamps.” Since LED emitters are current-controlled devices, voltage regulator circuits should use current-limiting resistors in series with each string of LED emitters (Figure 3.1a circuit), paralleled string of LED emitters (Figure 3.1b circuit), or cross-connected paralleled string of LED emitters (Figure 3.1c circuit). For voltage regulator circuits, Equation #3.2 can be used to calculate the value of the external current-limiting resistor(s) if the regulated output voltage,  $V_{OUT}$ , is substituted into the equation for  $V_{IN}$ . For current regulator circuits, external current limiting resistors are not required but their use can reduce forward current variations within the LED array.

As shown in Figure 3.21, there are three basic types of regulator circuits. The circuits shown in Figures 3.21a and 3.21d are called “shunt” regulators. They use a dynamic load in parallel with the load being regulated that shunts some of the supply current around the load. Shunt regulators also have a power resistor in series with both loads. The value of the power resistor has been selected such that at the minimum input voltage and maximum load condition, the current through the dynamic load goes to zero. At higher input voltages or smaller loads, the current through the dynamic load is increased, which increases the voltage drop across the power resistor to keep the load current or voltage constant. In this way, the shunt regulator maintains either a fixed current or voltage across the load. Shunt regulators are not very practical for automotive signal lamps

due to the large variations in input voltage and will not be covered further in this section.

The circuits shown in Figures 3.21b and 3.21e are called “series-pass” regulators. They use a dynamic load in series with the load being regulated. At minimum input voltages the voltage drop across the dynamic load goes to a minimum value. This minimum voltage drop is called the “drop-out” voltage. At higher input voltages, the voltage drop across the dynamic load increases so as to maintain either a fixed current or voltage across the load. At voltages below the drop-out voltage, the dynamic load can no longer regulate the output voltage or current. Thus, for proper voltage or current regulation, the input voltage needs to be higher than the sum of the drop-out voltage, the voltage across the load, and the voltage drop across the sense resistor (if applicable).

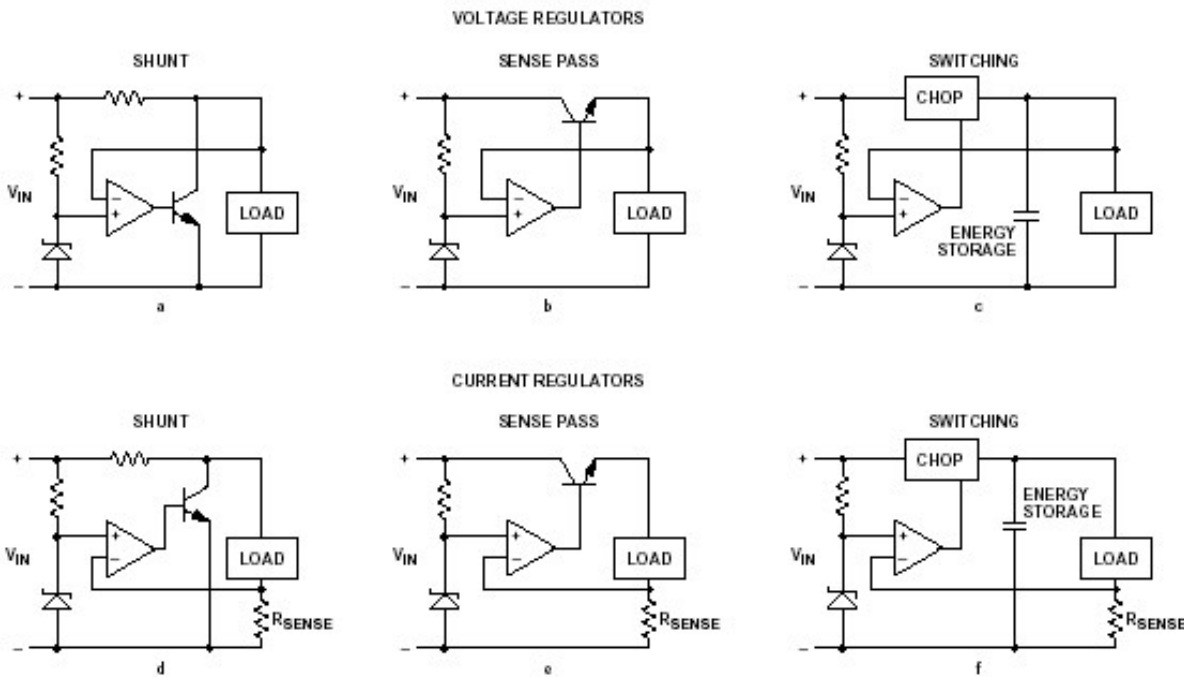

Figure 3.21 Block Diagrams of Several Active Drive Circuits for LED Signal Lamps.



The circuits shown in Figures 3.21c and 3.21f are called “switching” regulators. They use a dynamic load that is switched ON and OFF at very high frequencies at a varying duty cycle. The dynamic load supplies electrical power to an energy storage element such as a capacitor or an inductor or a combination of both. This energy storage element then supplies power to the load. The percentage of time the dynamic load is ON is varied depending on the input voltage and load requirements. The “switching” regulator provides the highest power efficiency of the three circuits. However, it is the most complex of the three regulator circuits and has the highest potential for creating unwanted EMI (due to the high-frequency switching).

The performance of these different types of regulators is compared with an example shown in the sidebar “Comparison of Three Constant-Current Circuits.”

The LED emitter array can be driven from either a voltage regulator or a current regulator circuit. With a current regulator, the total array current will be independent of supply voltage, temperature and forward voltage category variations as long as the current regulator remains in its active region. If the current regulator is used with parallel-connected LED emitters, such as shown in Figure 3.1b or 3.1c, there can still be similar forward current variations within the LED array as was discussed in the section “Key Concepts for the Electrical Design of LED Signal Lamps.” Note that the forward current matching can be improved with the addition of a small resistor ( $R_{OPT} > R_S$ ) in series with each string for the

circuit shown in Figure 3.1b or “rung” for the circuit shown in Figure 3.1c.

With a voltage regulator, the forward voltage applied to the LED array voltage will be independent of supply voltage variations as long as the voltage regulator remains in its active region. However, ambient temperature variations and the use of different forward voltage categories can affect the forward current through the LED array unless provisions are made in the design. As mentioned earlier, current limiting resistors,  $R$ , are needed for each string of LED emitters. With  $R > y \Delta R_S$ , the forward current through each string will primarily be determined by the value of  $R$ . If the designer uses a voltage regulator with a fixed output voltage, then the values of these current-limiting resistors will need to be varied for each of the different forward voltage categories in order to compensate for the different forward voltages at the design current. Alternatively, the designer could use the same value of current-limiting resistors for all forward voltage categories. However, in this case, the regulator output voltage would need to be varied slightly for each different forward voltage category to compensate for the different forward voltages at the design current. Despite these precautions, there will still be small variations in the total current through the LED array due to slightly different forward voltages of the individual emitters. With only a small voltage drop across the current limiting resistor, small variations in the regulated voltage can cause large changes in forward current through the LED emitters. In addition, since the forward voltage of the LED emitter varies with temperature, the forward current through the LED array will increase at elevated temperatures. However, it is possible

to maintain fixed current through the LED array if the output voltage of the regulator tracks the  $dV_F/dT$  of the LED array (approximately  $-2\text{ mV}/^\circ\text{C}$  times the number of emitters in each series string). Finally, if the voltage regulator is used with parallel-connected LED emitters, such as shown in Figure 3.1b or 3.1c, there can still be similar forward current variations within

the LED array as was discussed in the section “Key Concepts for Electrical Design of LED Signal Lamps.” Note that the forward current matching can be improved with the addition of a small resistor ( $R_{OPT} > R_S$ ) in series with each string for the circuit shown in Figure 3.1b or “rung” for the circuit shown in Figure 3.1c.

## Comparison of Three Constant-Current Circuits

### SETUP:

Suppose an LED signal lamp is being designed using 30 HPWT-DH00 SuperFlux LED emitters from forward voltage category 3. The circuit will be designed to operate at 50 mA per emitter at a design voltage of 12.8 V.

### PROBLEM STATEMENT:

How does the overall power consumption compare for the following 4 possible circuit designs over an input voltage range of 9 V to 18 V?

1. Resistive current limiting (Figure 3.1a circuit) with ten strings of three emitters per string.
2. Resistive current limiting (Figure 3.1a circuit) with eight strings of four emitters per string.
3. Series-pass constant-current regulator driving ten strings of three emitters per string.
4. Switching constant-current regulator driving ten strings of three emitters per string.

### SOLUTION:

For the first two designs, the value of the external current limiting resistor,  $R$ , can be determined using Equation #3.2. Note, for forward voltage category 3, the nominal linear forward voltage model is  $V_{O\text{ NOM}} = 1.91\text{ V}$ , and  $R_{S\text{ NOM}} = 9.2\text{ ohm}$ . Thus, for the three-LED string circuit,  $R = 114\text{ ohm}$ . For the four-LED string circuit,  $R = 66\text{ ohm}$ . The detailed designs are shown in Figure 3.22. Then over an input voltage range of 7 to 18 volts, the forward current through each LED string would vary as shown in Figure 3.23.

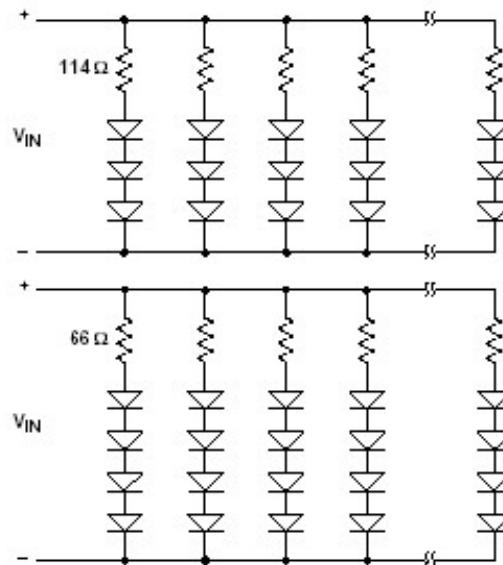

Figure 3.22 Two LED Signal Lamp Designs Using Resistive Current Limiting.

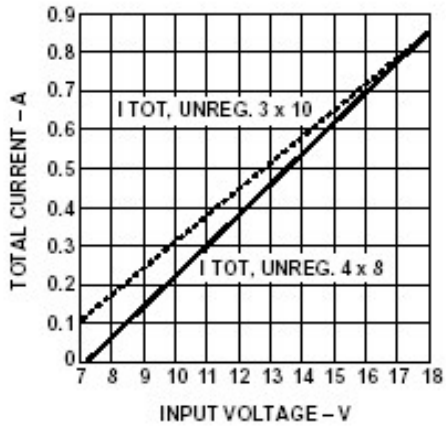

Figure 3.23 Forward Current Through LED Emitters as a Function of Applied Voltage for Resistive Limited Circuits Shown in Figure 3.22.

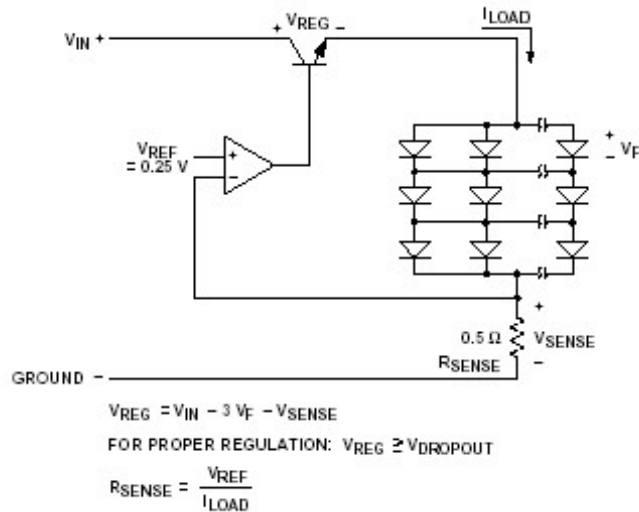

Figure 3.24 Block Diagram of LED Signal Lamp Design Using Series-Pass Constant-Current Regulator.

The key elements of the series pass constant-current regulator are shown in Figure 3.24. For series strings of three forward voltage category 3 HPWT-DH00 emitters, the forward voltage of the string is about 7.10 V at 50 mA. Assuming a voltage drop across the sense resistor of 0.25 V, then at an input voltage of 9 V, the drop-out voltage of the regulator would be (9 V – 7.1 V – 0.25 V), or 1.65 V. Since there are 10 strings of LED emitters, the total LED array current would be 50 mA times 10, or 500 mA. Thus, the sense resistor would be (0.25 V / 0.500 A), or 0.5 ohms. Then over an input voltage range of 7 to 18 volts, the total load current of the circuit would vary as shown in Figure 3.25. As designed, this circuit maintains a constant current through the LED array at input voltages greater than 9 V. Suppose that the minimum compliance voltage of the circuit is designed to be 10 V, then an additional volt can be dropped across the load or series pass regulator.

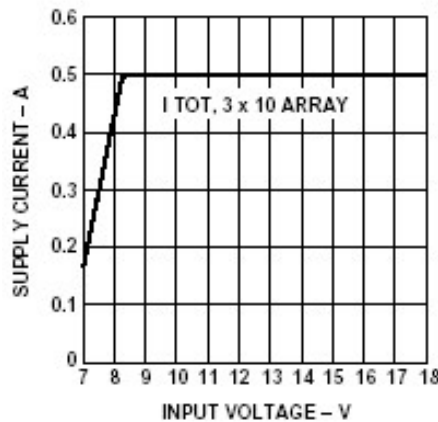

Figure 3.25 Forward Current Through LED Emitters as a Function of Applied Voltage for Series-Pass Constant-Current Regulator Circuit Shown in Figure 3.24.

The key elements of the switching constant-current regulator are shown in Figure 3.26. There are a number of different types of switching regulators. Buck or Down Converters are designed to generate a regulated output voltage that is always less than the input voltage. Boost or Up Converters are capable of generating a regulated output voltage that is always higher than the input voltage. Buck/Boost or Up/Down Converters can generate a regulated output voltage using any input voltage. By comparison,

current-limiting resistors and series-pass regulators can only reduce the output voltage to a lower value than the input voltage. Thus for some types of switching regulator circuits the number of LED emitters per string can be larger than the number of LED emitters per string for a resistor-limited or series-pass regulator circuit. In general, the switching regulator converts the average input power ( $V_{IN}$  times  $I_{IN}$ ) to the desired output power ( $V_{LOAD}$  times  $I_{LOAD}$ ) with a relatively fixed power conversion efficiency. At higher

input voltages, the efficiency of the switching regulator is better than the series-pass regulator and the resistor-limited circuits. Assuming a  $0.25\text{ V}$  drop across the sense resistor, then for the ten-string circuit,  $R_{SENSE}$  would be equal to  $(0.25\text{ V} / 0.500\text{ A})$ , or  $0.5\text{ ohms}$ . Assuming a power conversion efficiency of 80% and an input voltage range of 7 to 18 volts, then the input current and total load current of the circuit would vary as shown in Figure 3.27.

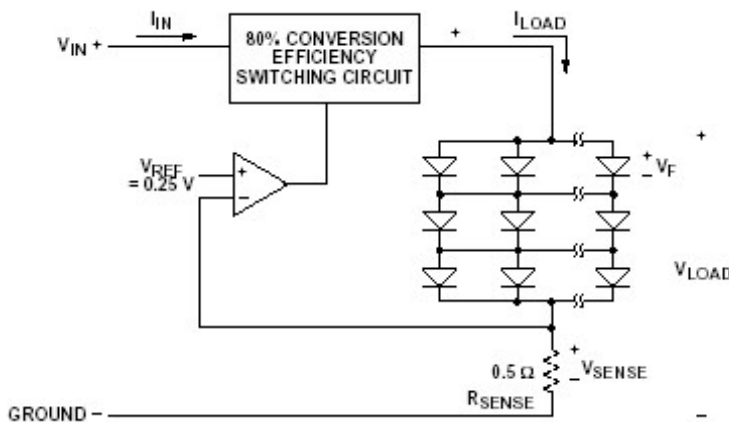

Figure 3.26 Block Diagram of LED Signal Lamp Design Using Switching Constant-Current Regulator.

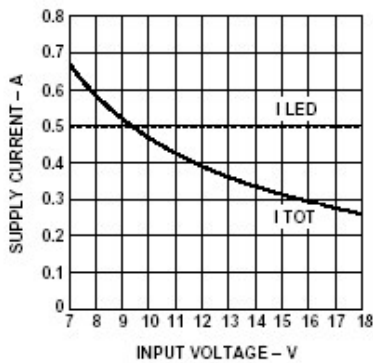

Figure 3.27 Forward Current Through LED Emitters as a Function of Applied Voltage for Switching Constant-Current Regulator Circuit Shown in Figure 3.26.

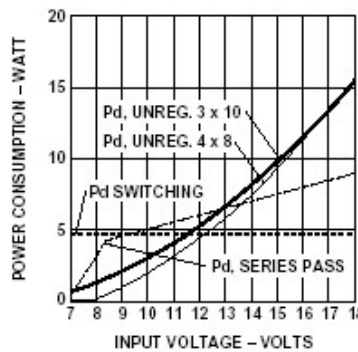

Figure 3.28 Comparison of Total Supply Current versus Applied Voltage for Circuit Designs Shown in Figures 3.22, 3.24 and 3.26.

The total power consumption for the four different LED signal lamp designs is shown in Figure 3.28. The series pass and switching regulator designs provide substantial power savings compared to the resistor-controlled circuits during over-voltage conditions. Note

that at an input voltage of 18 V, both resistor limited circuits have an overall power consumption of 15 W. The series pass current regulator circuit has an overall power consumption of 9 W. The switching current regulator has an overall power consumption of 5 W.

## Company Information

---

Lumileds is a world-class supplier of Light Emitting Diodes (LEDs) producing billions of LEDs annually. Lumileds is a fully integrated supplier, producing core LED material in all three base colors (Red, Green, Blue) and White. Lumileds has R&D development centers in San Jose, California and Best, The Netherlands. Production capabilities in San Jose, California and Malaysia.

Lumileds is pioneering the high-flux LED technology and bridging the gap between solid state LED technology and the lighting world. Lumileds is absolutely dedicated to bringing the best and brightest LED technology to enable new applications and markets in the Lighting world.



©2002 Lumileds Lighting. All rights reserved. Lumileds Lighting is a joint venture between Agilent Technologies and Philips Lighting. Luxeon is a trademark of Lumileds Lighting, Inc. Product specifications are subject to change without notice.

Publication No. AB20-3 (Sept2002)

## LUMILEDS

[www.luxeon.com](http://www.luxeon.com)  
[www.lumileds.com](http://www.lumileds.com)

For technical assistance or the location of your nearest Lumileds sales office, call:

Worldwide:  
+1 408-435-6044  
US Toll free: 877-298-9455  
Europe: +31 499 339 439  
Fax: 408-435-6855  
Email us at [info@lumileds.com](mailto:info@lumileds.com)

Lumileds Lighting, LLC  
370 West Trimble Road  
San Jose, CA 95131