

**Silicon NPN Power Transistors**

**2SC3725**

**DESCRIPTION**

- With TO-3PN package
- High voltage ,high speed switching
- High reliability

**APPLICATIONS**

- Switching regulators
- Ultrasonic generators
- High frequency inverters
- General purpose power amplifiers

**PINNING**

PIN	DESCRIPTION
1	Base
2	Collector;connected to mounting base
3	Emitter

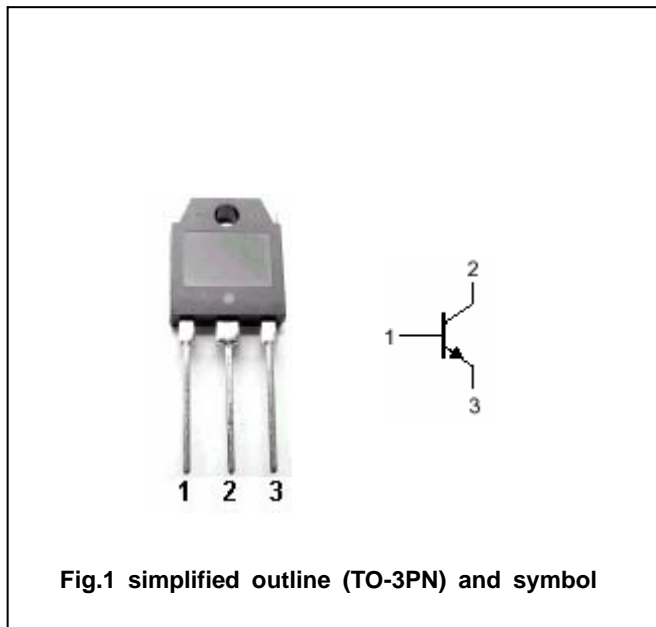

Fig.1 simplified outline (TO-3PN) and symbol

**Absolute maximum ratings(Ta= )**

SYMBOL	PARAMETER	CONDITIONS	VALUE	UNIT
V <sub>CB0</sub>	Collector-base voltage	Open emitter	450	V
V <sub>CEO</sub>	Collector-emitter voltage	Open base	400	V
V <sub>EBO</sub>	Emitter-base voltage	Open collector	10	V
I <sub>C</sub>	Collector current		15	A
I <sub>B</sub>	Base current		5	A
P <sub>C</sub>	Collector power dissipation	T <sub>C</sub> =25	80	W
T <sub>j</sub>	Junction temperature		150	
T <sub>stg</sub>	Storage temperature		-55~150	

**THERMAL CHARACTERISTICS**

SYMBOL	PARAMETER	MAX	UNIT
R <sub>th j-c</sub>	Thermal resistance junction case	1.56	/W

## Silicon NPN Power Transistors

## 2SC3725

## CHARACTERISTICS

T<sub>j</sub>=25 unless otherwise specified

SYMBOL	PARAMETER	CONDITIONS	MIN	TYP.	MAX	UNIT
V <sub>(BR)CEO</sub>	Collector-emitter breakdown voltage	I <sub>C</sub> =10mA ; I <sub>B</sub> =0	400			V
V <sub>(BR)CBO</sub>	Collector-base breakdown voltage	I <sub>C</sub> =1mA ; I <sub>E</sub> =0	450			V
V <sub>(BR)EBO</sub>	Emitter-base breakdown voltage	I <sub>E</sub> =1mA ; I <sub>C</sub> =0	10			V
V <sub>CEsat</sub>	Collector-emitter saturation voltage	I <sub>C</sub> =6A ; I <sub>B</sub> =1.2A			0.8	V
V <sub>BEsat</sub>	Base-emitter saturation voltage	I <sub>C</sub> =6A ; I <sub>B</sub> =1.2A			1.2	V
I <sub>CBO</sub>	Collector cut-off current	V <sub>CB</sub> =450V ; I <sub>E</sub> =0			100	μ A
I <sub>EBO</sub>	Emitter cut-off current	V <sub>EB</sub> =10V ; I <sub>C</sub> =0			100	μ A
h <sub>FE</sub>	DC current gain	I <sub>C</sub> =6A ; V <sub>CE</sub> =5V	10			

## Switching times

t <sub>on</sub>	Turn-on time	I <sub>C</sub> =6A ; I <sub>B1</sub> =2A I <sub>B2</sub> =-4A ; R <sub>L</sub> =15			1.0	μ s
t <sub>s</sub>	Storage time				2.5	μ s
t <sub>f</sub>	Fall time				0.5	μ s

Silicon NPN Power Transistors

2SC3725

PACKAGE OUTLINE

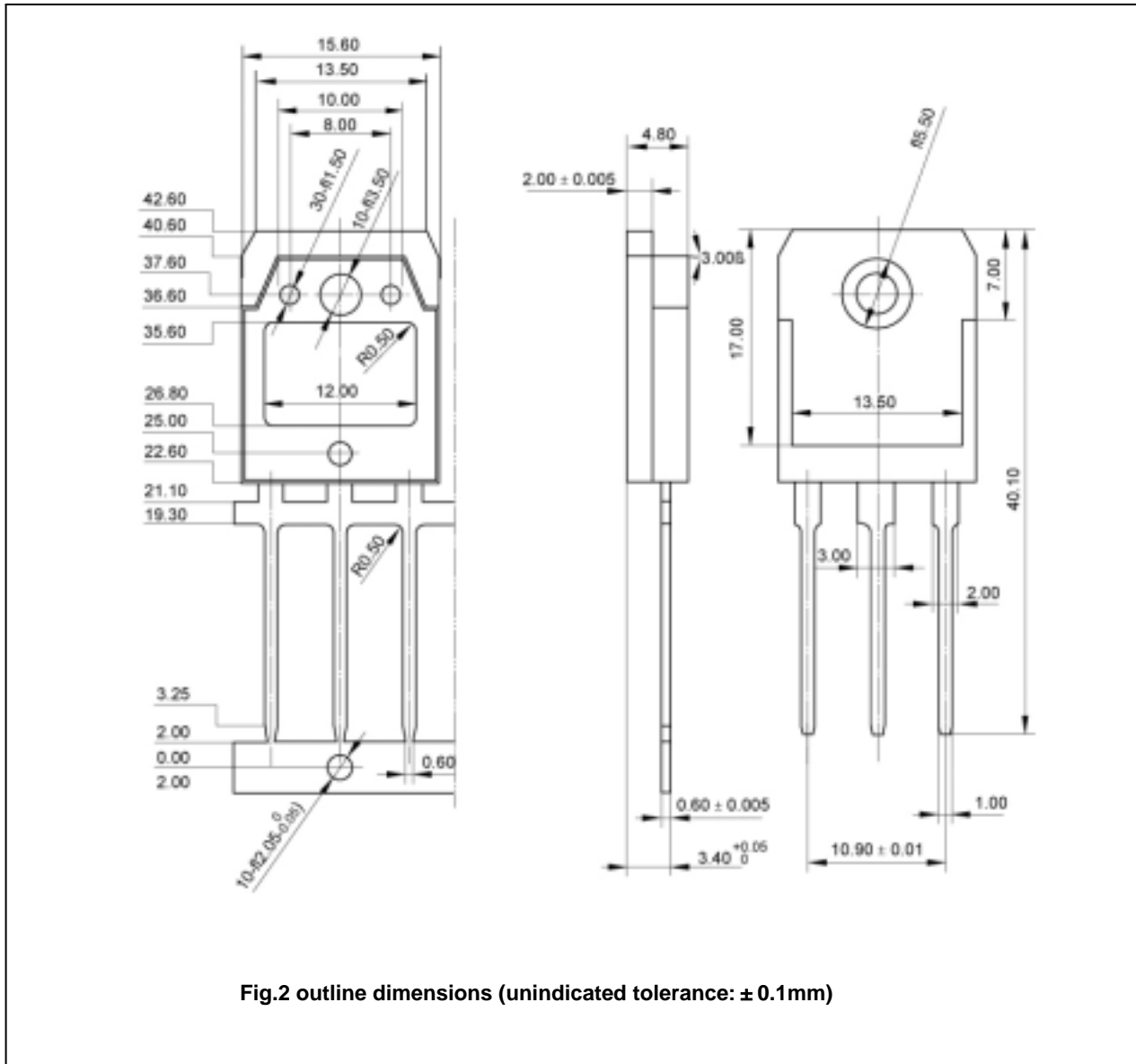

Fig.2 outline dimensions (unindicated tolerance: ± 0.1mm)