

R2J20651ANP

Integrated Driver – MOS FET (DrMOS)

REJ03G1792-0100
Rev.1.00
Jun 03, 2009

Description

The R2J20651ANP multi-chip module incorporates a high-side MOS FET, low-side MOS FET, and MOS-FET driver in a single QFN package. The on and off timing of the power MOS FET is optimized by the built-in driver, making this device suitable for large-current buck converters. The chip also incorporates a high-side bootstrap Schottky barrier diode (SBD), eliminating the need for an external SBD for this purpose.

Features

- Compliant with Intel 6 × 6 DrMOS specification
- Built-in power MOS FET suitable for applications with 5 V/12 V input
- Built-in driver circuit which matches the power MOS FET
- Built-in tri-state input function which can support a number of PWM controllers
- VIN operating-voltage range: 16 V max
- High-frequency operation (above 1 MHz) possible
- Large average output current (Max. 35 A)
- Achieve low power dissipation
- Controllable driver: Remote on/off
- Low-side MOS FET disabled function for DCM operation
- Built-in thermal warning
- Built-in Schottky diode for bootstrapping
- Small package: QFN40 (6 mm × 6 mm × 0.95 mm)
- Terminal Pb-free/Halogen-free

Outline

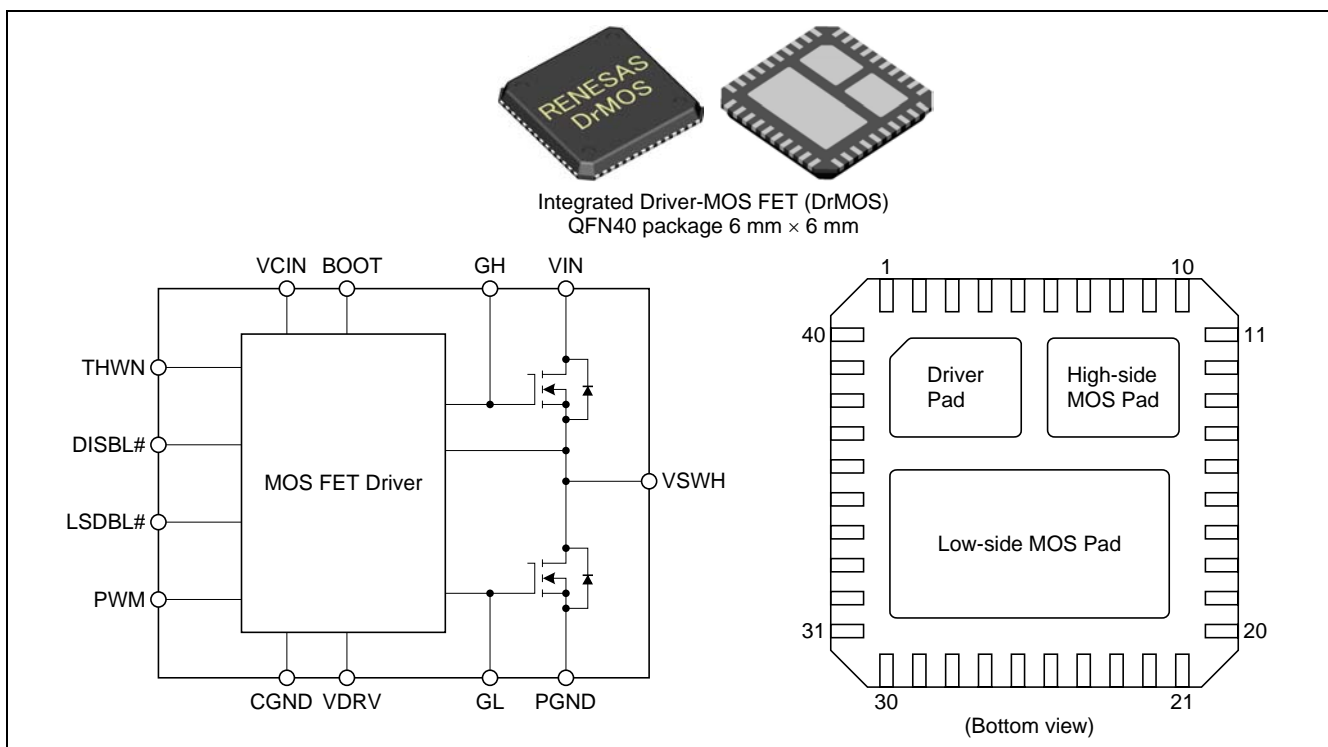

Block Diagram

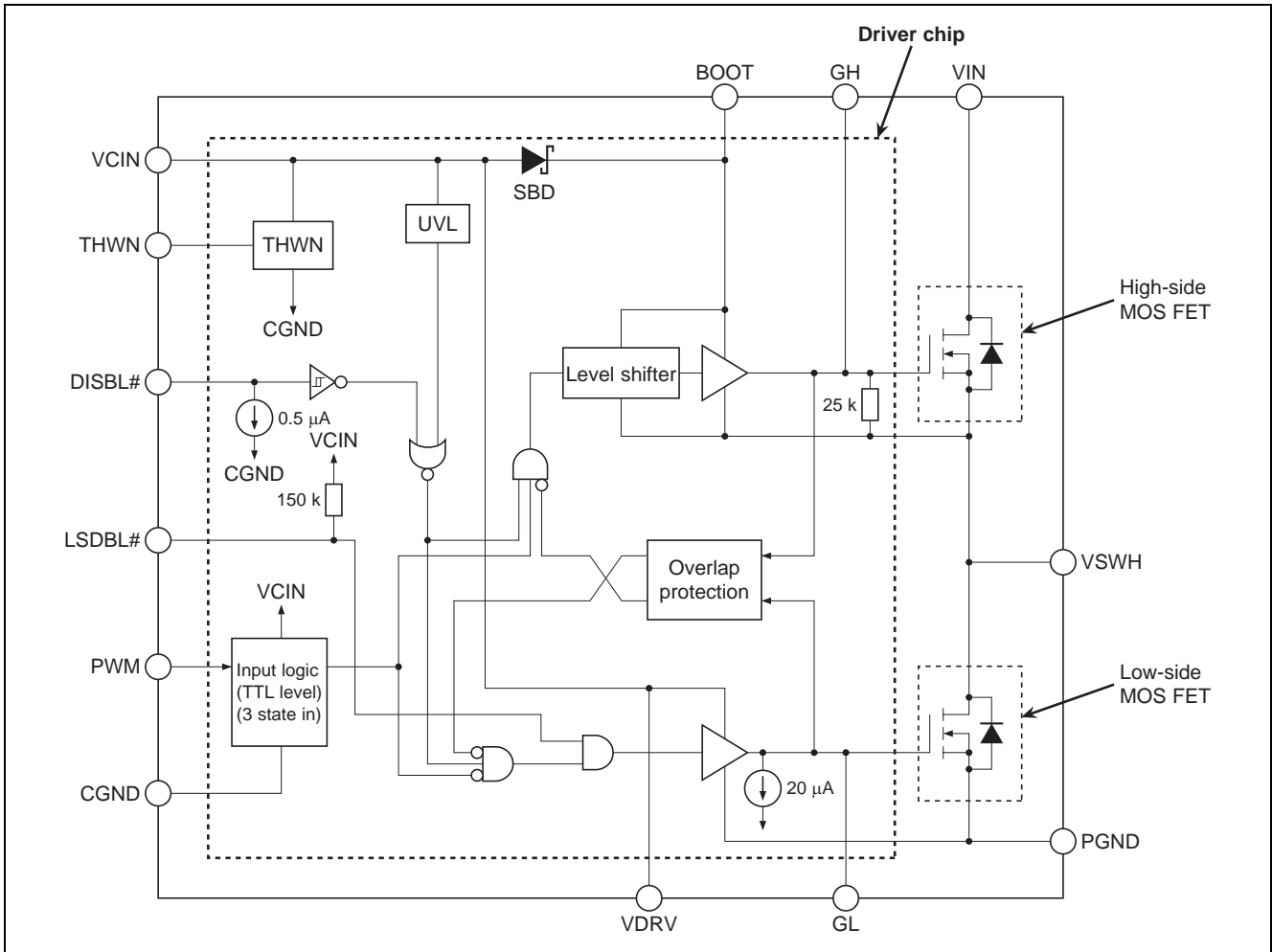

Notes: 1. Truth table for the DISBL# pin.

DISBL# Input	Driver Chip Status
"L"	Shutdown (GL, GH = "L")
"Open"	Shutdown (GL, GH = "L")
"H"	Enable (GL, GH = "Active")

2. Truth table for the LSDBL# pin.

LSDBL# Input	GL Status
"L"	"L"
"Open"	"Active"
"H"	"Active"

3. Output signal from the UVL block

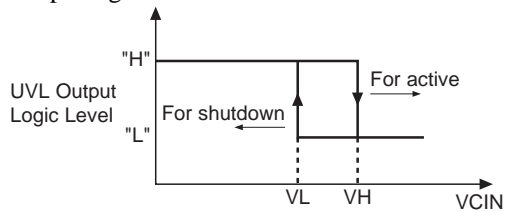

4. Output signal from the THWN block

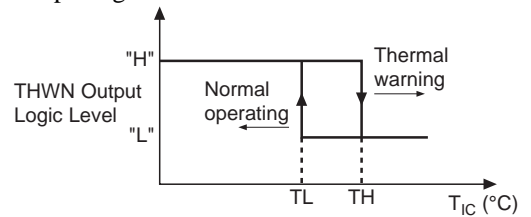

Pin Arrangement

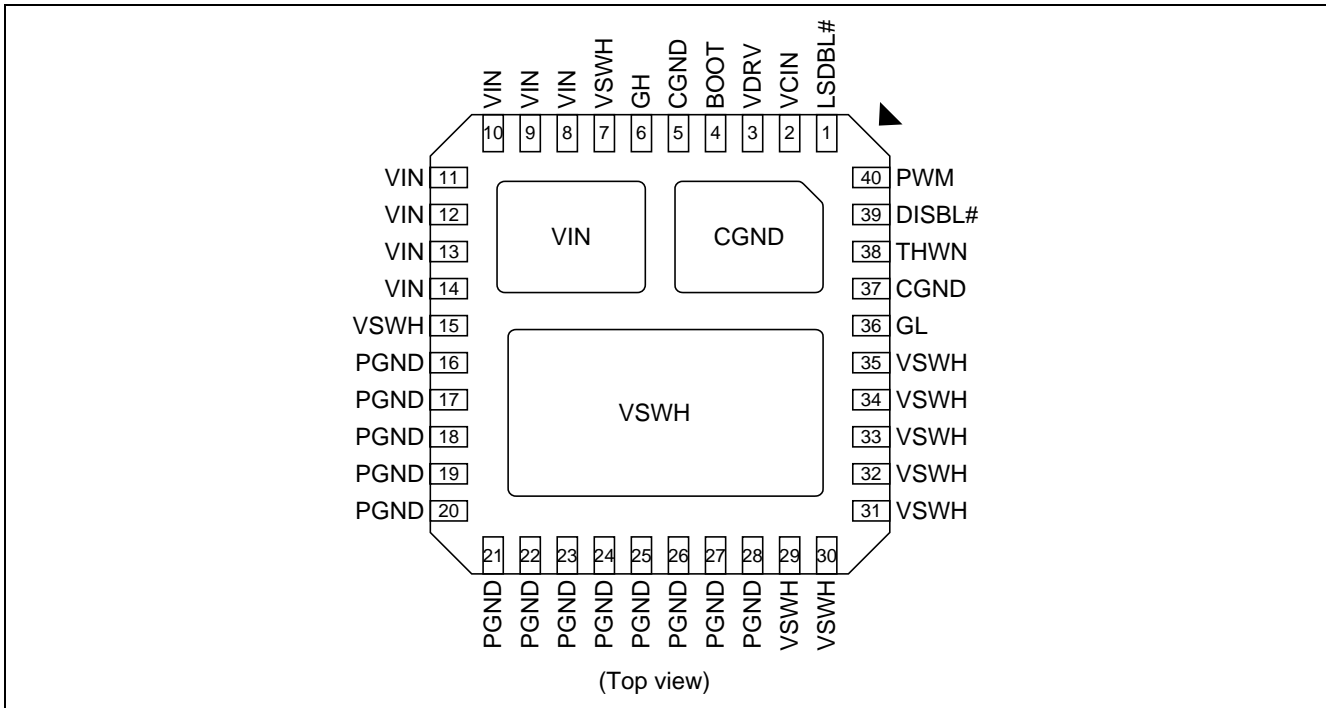

Note: All die-pads (three pads in total) should be soldered to PCB.

Pin Description

Pin Name	Pin No.	Description	Remarks
LSDBL#	1	Low-side gate disable	When asserted "L" signal, Low-side gate disable
VCIN	2	Control input voltage (+5 V input)	Driver Vcc input
VDRV	3	Gate supply voltage (+5 V input)	5 V gate drive
BOOT	4	Bootstrap voltage pin	To be supplied +5 V through internal SBD
CGND	5, 37, Pad	Control signal ground	Should be connected to PGND externally
GH	6	High-side gate signal	Pin for Monitor
VIN	8 to 14, Pad	Input voltage	
VSWH	7, 15, 29 to 35, Pad	Phase output/Switch output	
PGND	16 to 28	Power ground	
GL	36	Low-side gate signal	Pin for Monitor
THWN	38	Thermal warning	Thermal warning when over 130°C
DISBL#	39	Signal disable	Disabled when DISBL# is "L"
PWM	40	PWM drive logic input	5 V logic input

Absolute Maximum Ratings

(Ta = 25°C)

Item	Symbol	Rating	Units	Note
Power dissipation	Pt(25)	25	W	1
	Pt(110)	8		
Average output current	Iout	35	A	
Input voltage	VIN (DC)	-0.3 to +16	V	2
	VIN (AC)	20		2, 3
Supply voltage & Drive voltage	VCIN & VDRV	-0.3 to +6	V	2
Switch node voltage	VSWH (DC)	16	V	2
	VSWH (AC)	25		2, 3
BOOT voltage	VBOOT (DC)	22	V	2
	VBOOT (AC)	25		2, 3
I/O voltage	Vpwm, Vdisble, Vlsdbl, Vthwn	-0.3 to VCIN + 0.3	V	2, 4
Operating junction temperature	Tj-opr	-40 to +150	°C	
Storage temperature	Tstg	-55 to +150	°C	

- Notes: 1. Pt(25) represents a PCB temperature of 25°C, and Pt(110) represents 110°C.
 2. Rated voltages are relative to voltages on the CGND and PGND pins.
 3. The specification values indicated "AC" are limited within 100 ns.
 4. VCIN + 0.3 V < 6 V

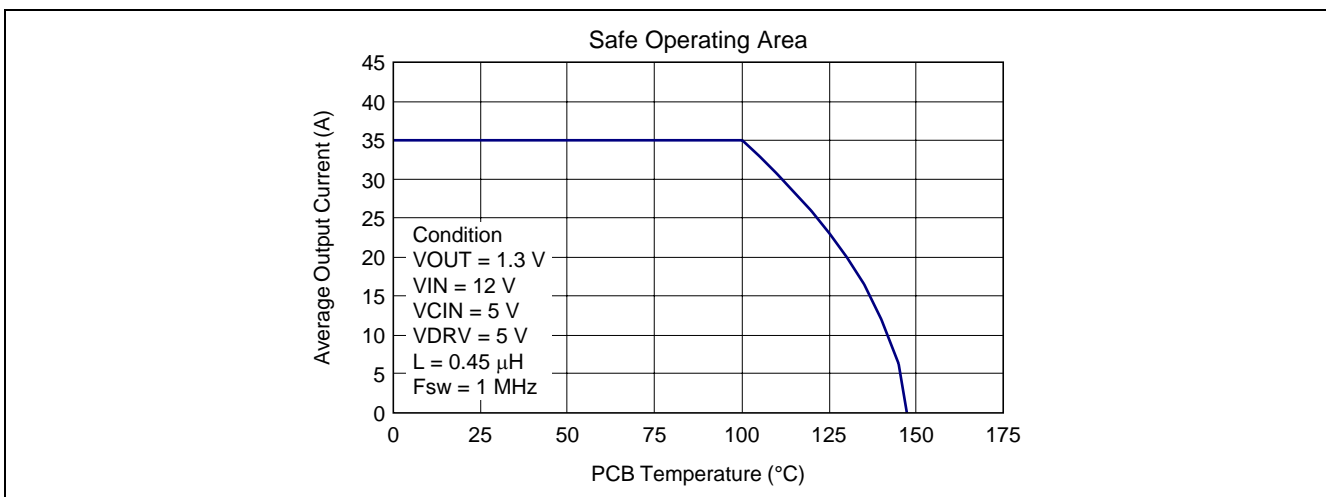

Recommended Operating Condition

Item	Symbol	Rating	Units	Note
Input voltage	VIN	4.5 to 14	V	
Supply voltage & Drive voltage	VCIN & VDRV	4.5 to 5.5	V	

Electrical Characteristics

($T_a = 25^\circ\text{C}$, $V_{\text{CIN}} = 5\text{ V}$, $V_{\text{DRV}} = 5\text{ V}$, $V_{\text{SWH}} = 0\text{ V}$, unless otherwise specified)

	Item	Symbol	Min	Typ	Max	Units	Test Conditions
Supply	VCIN start threshold	V_H	3.1	3.5	3.9	V	
	VCIN shutdown threshold	V_L	2.7	3.0	3.3	V	
	UVLO hysteresis	$dUVL$	—	0.5	—	V	$V_H - V_L$
	VCIN operating current	I_{CIN}	—	29	—	mA	$f_{\text{PWM}} = 1\text{ MHz}$, $T_{\text{on_pwm}} = 120\text{ ns}$
	VCIN disable current	$I_{\text{CIN-DISBL}}$	—	—	50	μA	DISBL# = 0 V, PWM = 0 V, LSDBL# = Open
PWM input	PWM rising threshold	$V_{\text{H-PWM}}$	3.3	3.7	4.1	V	
	PWM falling threshold	$V_{\text{L-PWM}}$	0.9	1.2	1.5	V	
	PWM input resistance	$R_{\text{IN-PWM}}$	10	20	40	$\text{k}\Omega$	PWM = 1 V
	Tri-state shutdown window	$V_{\text{IN-SD}}$	$V_{\text{L-PWM}}$	—	$V_{\text{H-PWM}}$	V	
	Shutdown hold-off time	$t_{\text{HOLD-OFF}}^{*1}$	—	100	—	ns	
DISBL# input	Disable threshold	V_{DISBL}	0.9	1.2	1.5	V	
	Enable threshold	V_{ENBL}	1.9	2.4	2.9	V	
	Input current	I_{DISBL}	—	0.5	2.0	μA	DISBL# = 1 V
LSDBL# input	Low-side activation threshold	V_{LSDBLH}	1.9	2.4	2.9	V	
	Low-side disable threshold	V_{LSDBLL}	0.9	1.2	1.5	V	
	Input current	I_{LSDBL}	-54	-27	-13.5	μA	LSDBL# = 1 V
Thermal warning	Warning temperature	T_{THWN}^{*1}	110	130	—	$^\circ\text{C}$	Driver IC temperature
	Temperature hysteresis	T_{HYS}^{*1}	—	15	—	$^\circ\text{C}$	
	THWN on resistance	R_{THWN}^{*1}	1.0	2.5	4.0	$\text{k}\Omega$	THWN = 1 V
	THWN leakage current	I_{LEAK}	—	0.001	1.0	μA	THWN = 5 V

Note: 1. Reference values for design. Not 100% tested in production.

Pin Connection

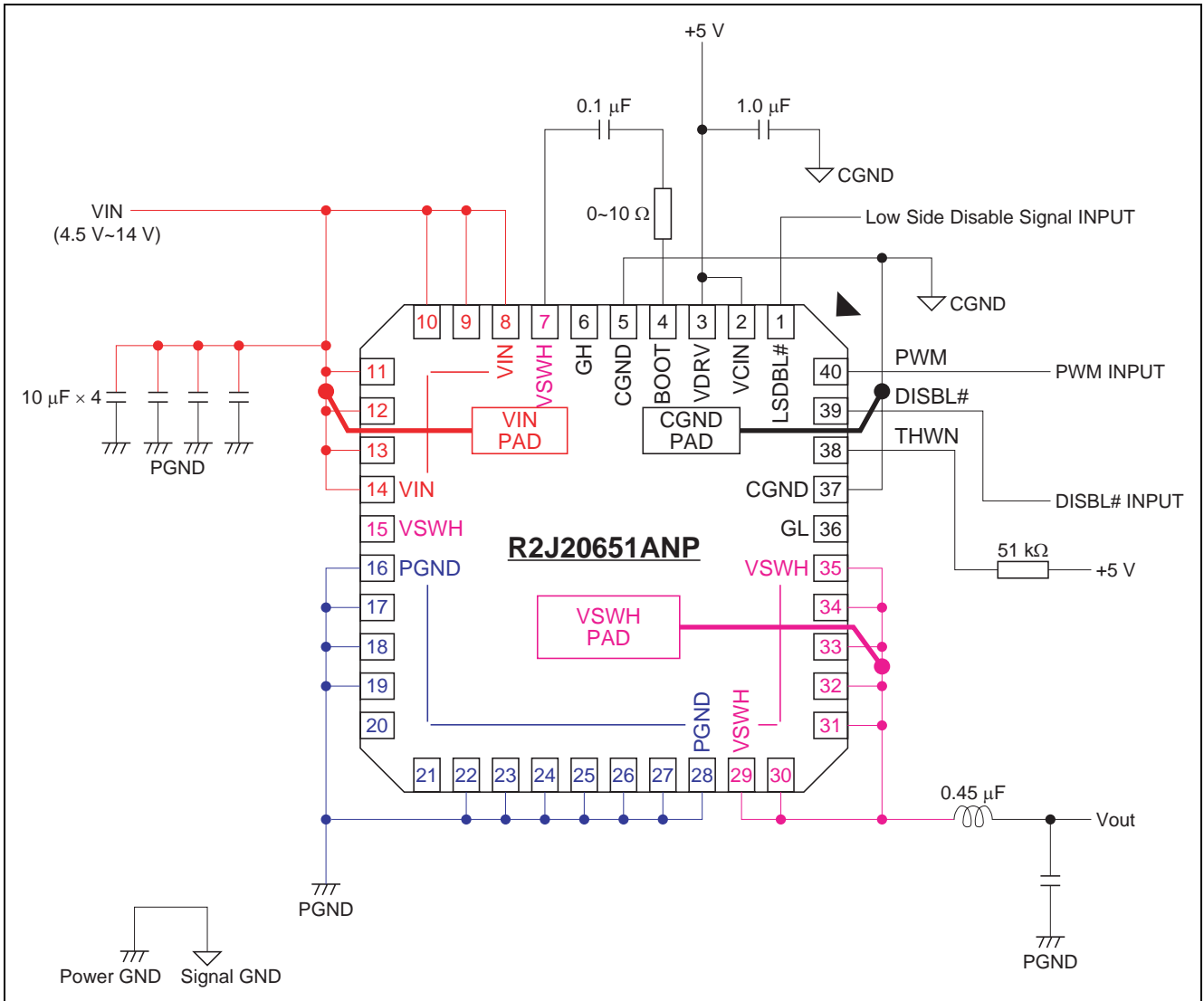

Typical Application

(1) 12 V Input Power

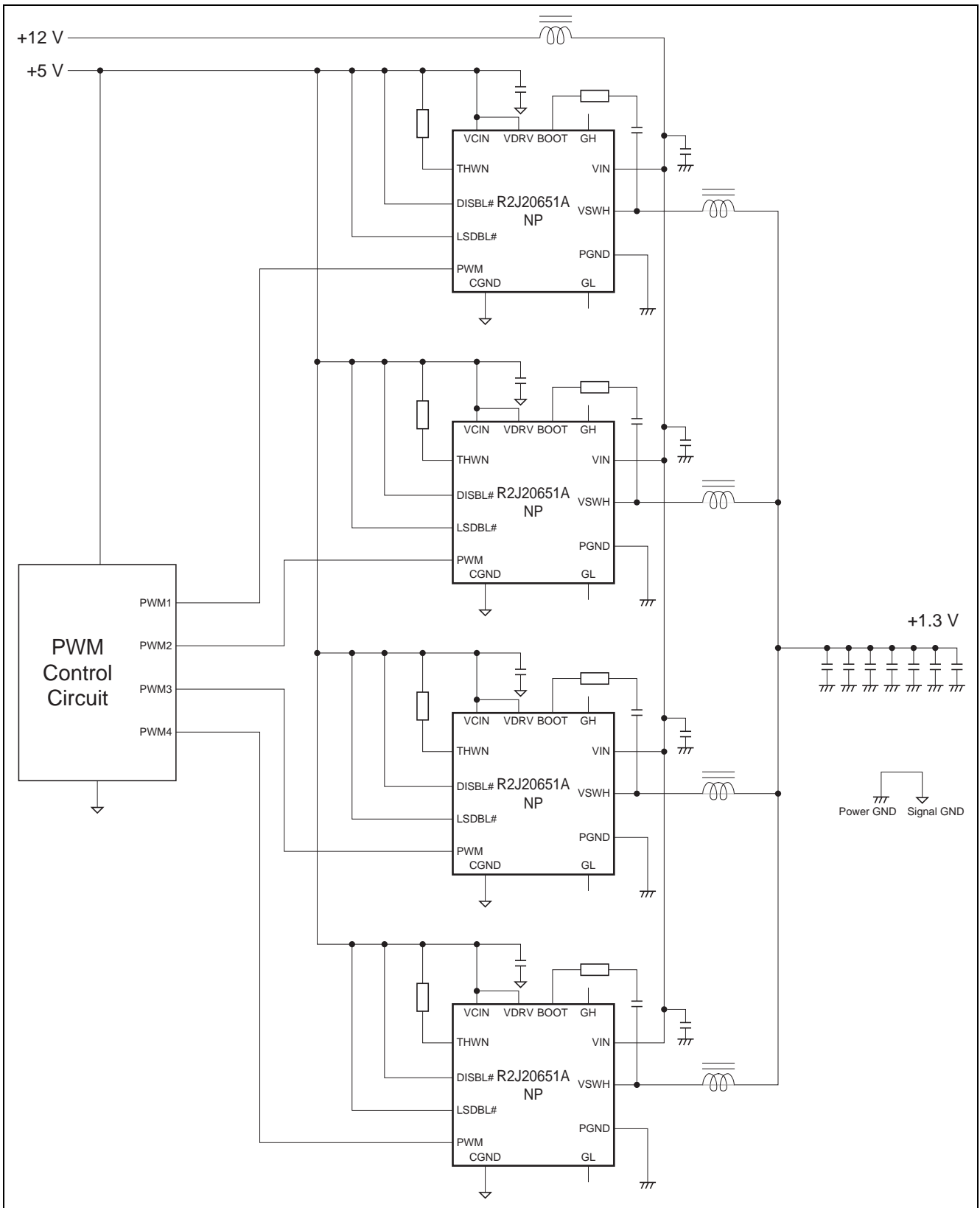

(2) 5 V Input Power

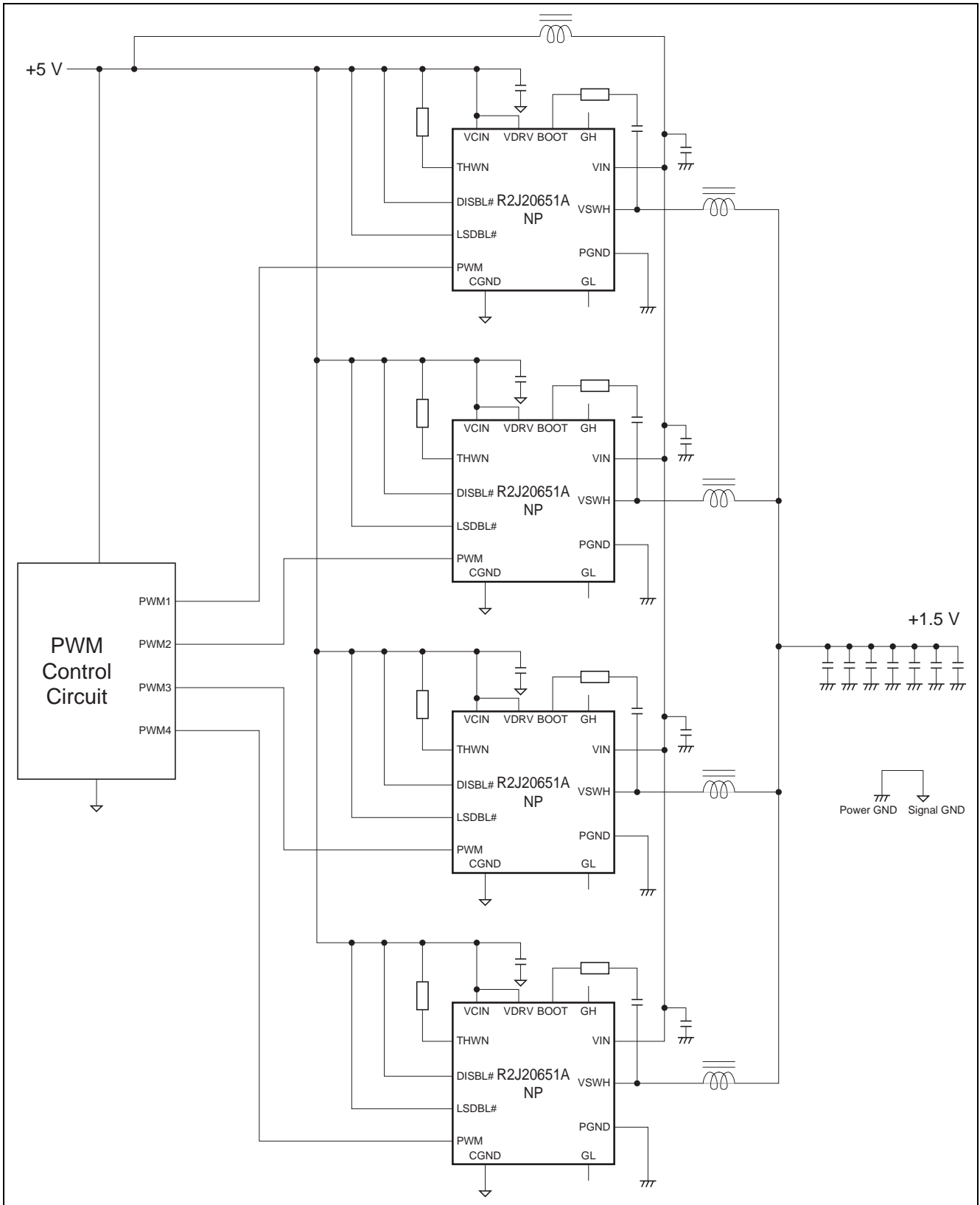

Test Circuit

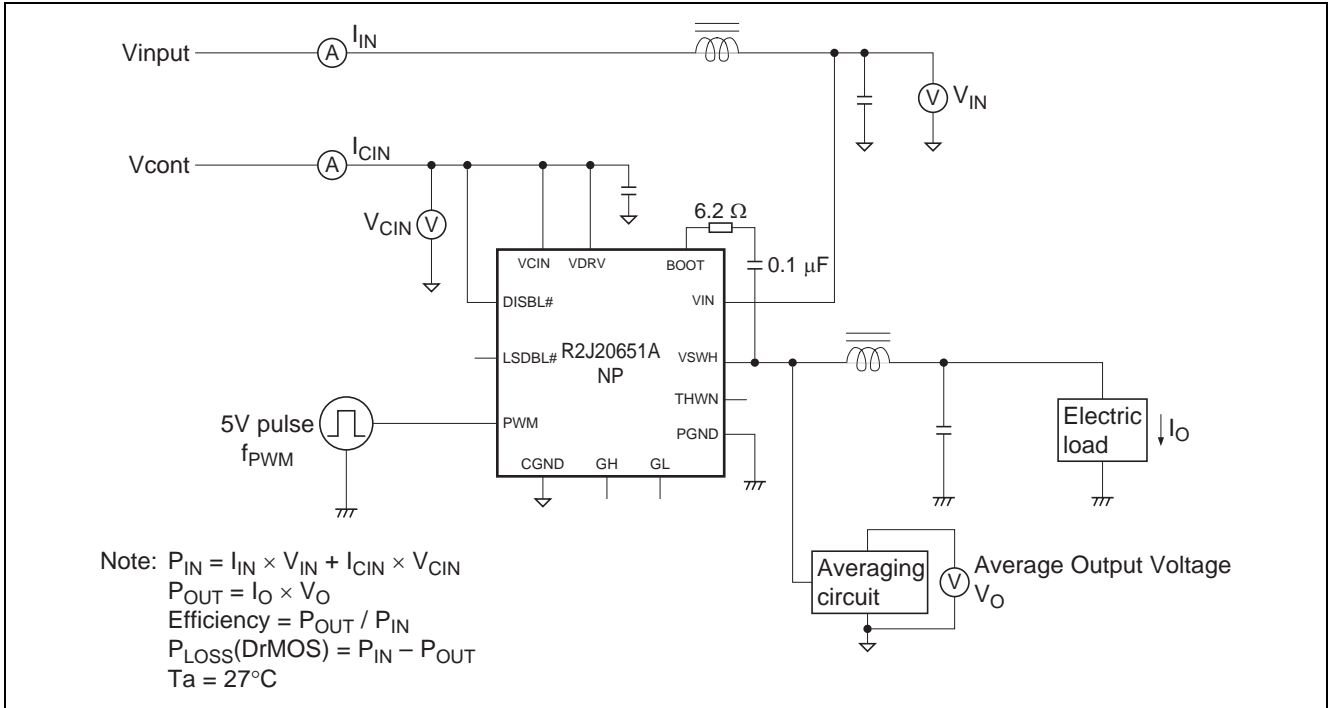

Typical Data

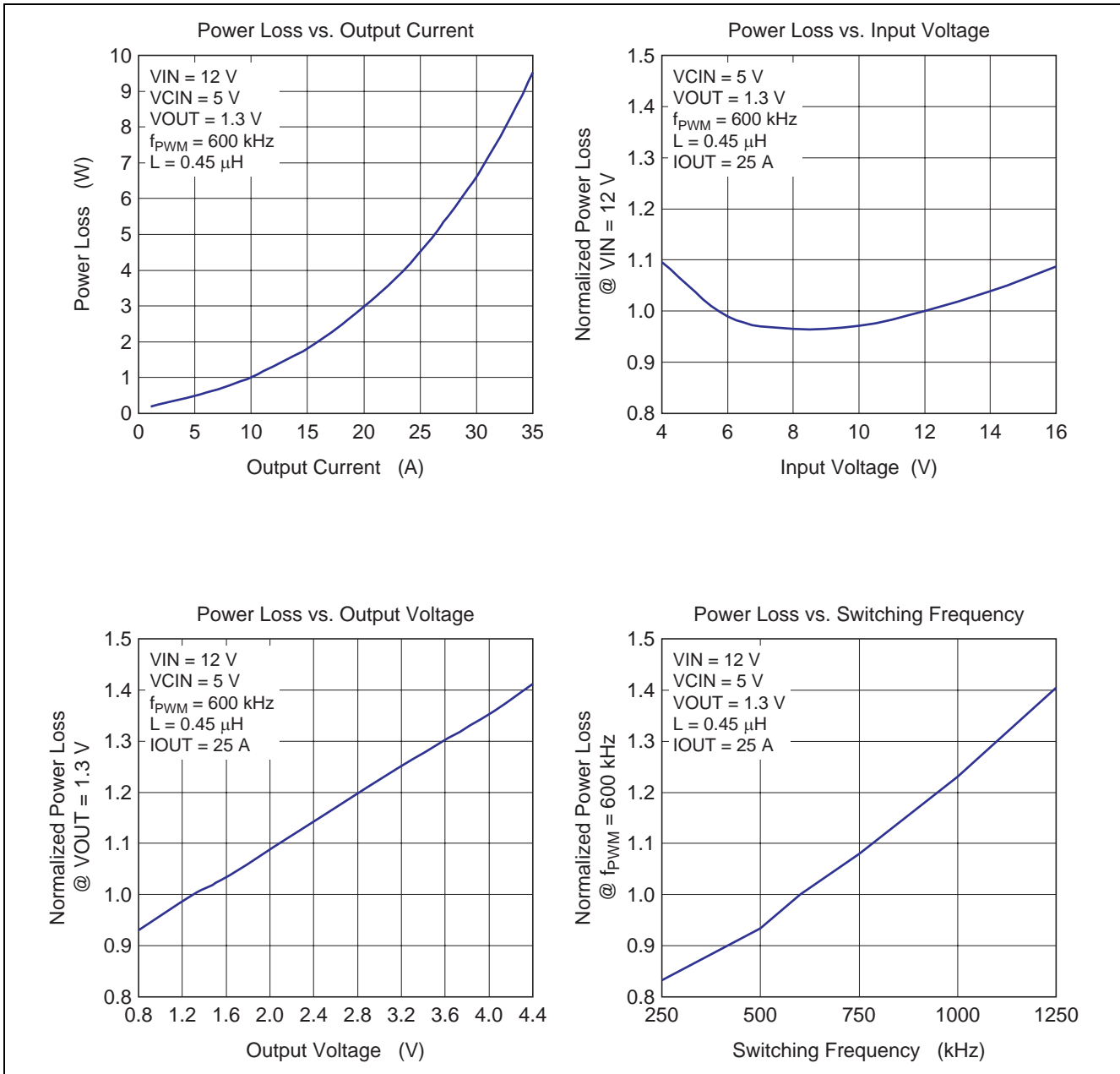

Typical Data (cont.)

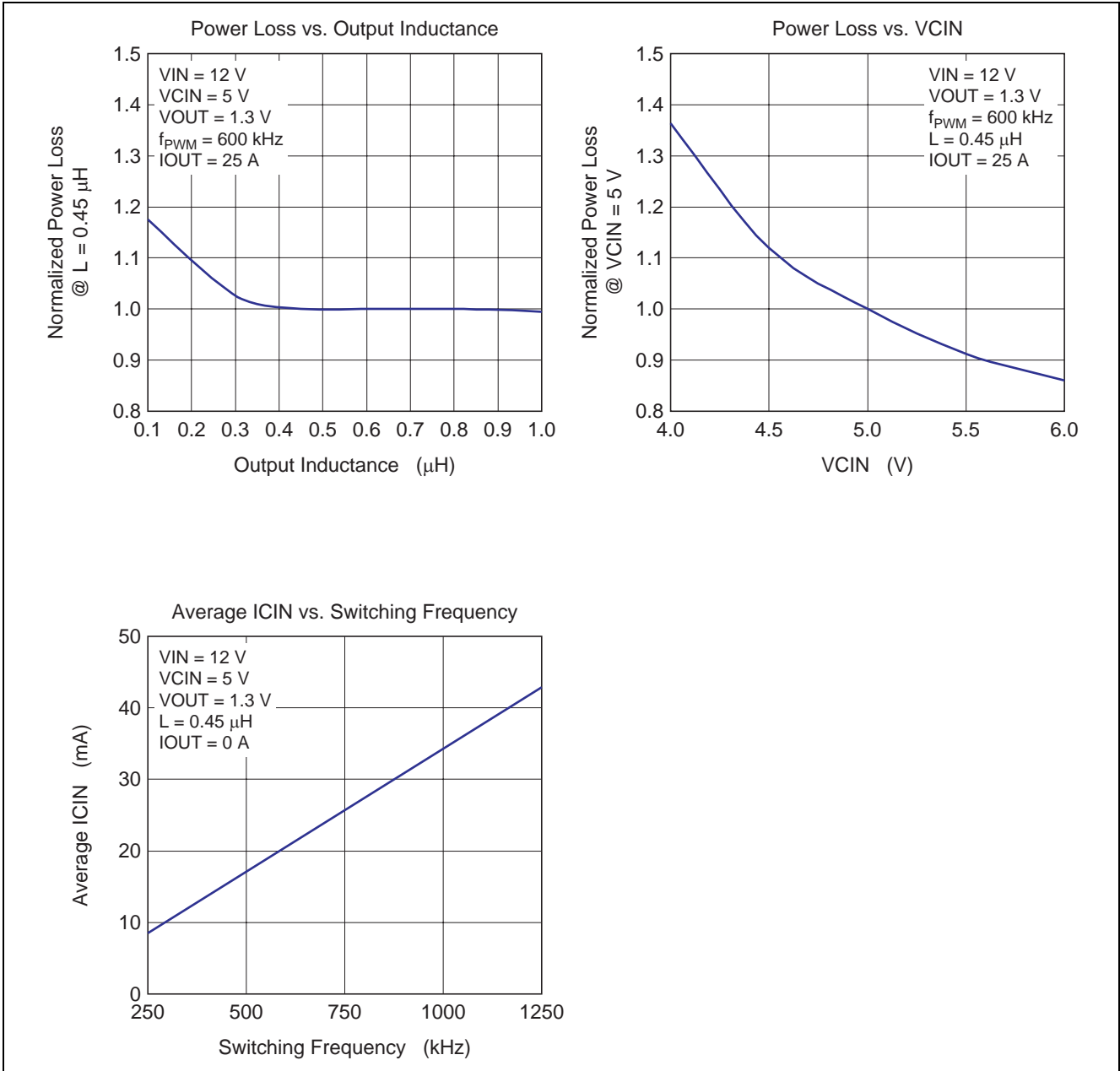

Description of Operation

The DrMOS multi-chip module incorporates a high-side MOS FET, low-side MOS FET, and MOS-FET driver in a single QFN package. Since the parasitic inductance between each chip is extremely small, the module is highly suitable for use in buck converters to be operated at high frequencies. The control timing between the high-side MOS FET, low-side MOS FET, and driver is optimized so that high efficiency can be obtained at low output-voltage.

VCIN & DISBL#

The VCIN pin is connected to the UVL (under-voltage lockout) module, so that the driver is disabled as long as VCIN is 3.5 V or less. On cancellation of UVL, the driver remains enabled until the UVL input is driven to 3.0 V or less. The signal on pin DISBL# also enables or disables the circuit.

Voltages from -0.3 V to VCIN can be applied to the DISBL# pin, so on/off control by a logic IC or the use of a resistor, etc., to pull the DISBL# line up to VCIN are both possible.

VCIN	DISBL#	Driver State
L	*	Disable (GL, GH = L)
H	L	Disable (GL, GH = L)
H	H	Active
H	Open	Disable (GL, GH = L)

PWM & LSDBL#

The PWM pin is the signal input pin for the driver chip. The input-voltage range is -0.3 V to $(VCIN + 0.3$ V). When the PWM input is high, the gate of the high-side MOS FET (GH) is high and the gate of the low-side MOS FET (GL) is low.

PWM	GH	GL
L	L	H
H	H	L

The LSDBL# pin is the low-side gate disable pin for "Discontinuous Conduction Mode (DCM)" when LSDBL# is low.

Figure 1 shows the typical high-side and low-side gate switching and inductor current (I_L) during Continuous Conduction Mode (CCM) and low-side gate disabled when asserting low-side disable signal.

This pin is internally pulled up to VCIN with 150 k Ω resistor.

When low-side disable function is not used, keep this pin open or pulled up to VCIN.

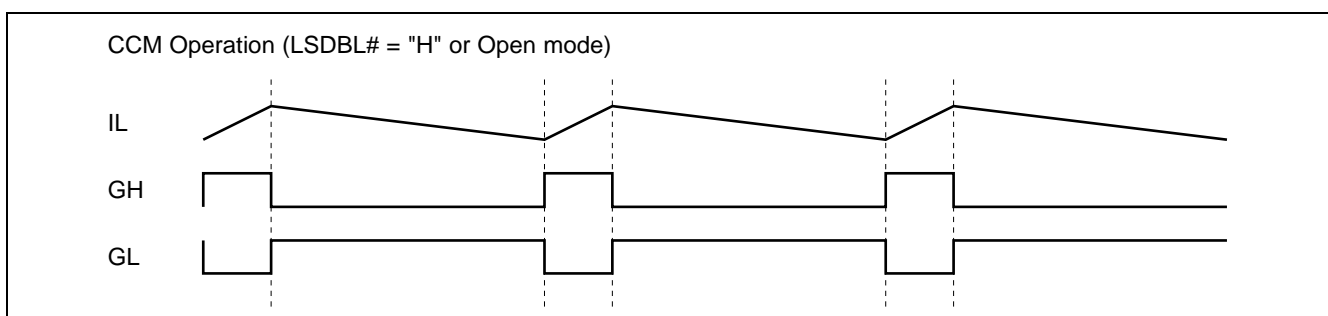

Figure 1.1 Typical Signals During CCM

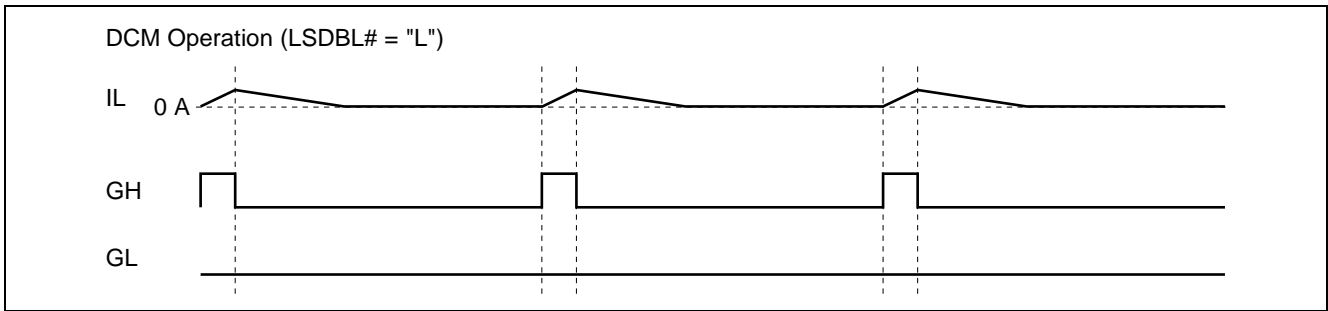

Figure 1.2 Typical Signals during Low-Side Disable Operation

The PWM input is TTL level and has hysteresis. When the signal route from the control IC is high impedance, the tri-state function turns off the high- and low-side MOS FETs. This function operates when the PWM input signal stays in the input hysteresis window for 100 ns (typ.). After the tri-state mode has been entered and GH and GL have become low, a PWM input voltage of 3.7 V or more is required to make the circuit return to normal operation.

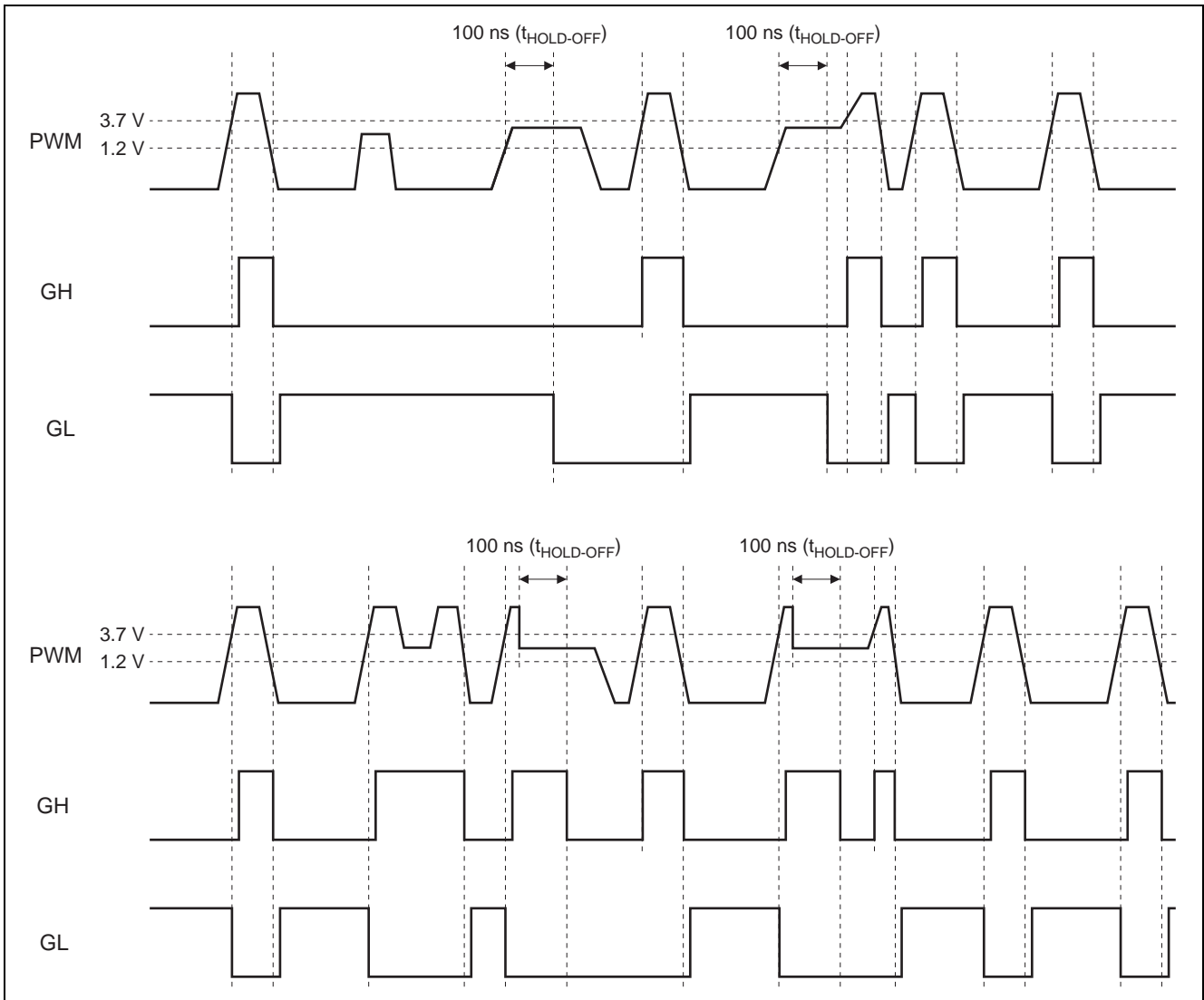

Figure 2

The equivalent circuit for the PWM-pin input is shown in the next figure. M1 is in the ON state during normal operation; after the PWM input signal has stayed in the hysteresis window for 100 ns (typ.) and the tri-state detection signal has been driven high, the transistor M1 is turned off.

When VCIN is powered up, M1 is started in the OFF state regardless of PWM Low or Open state. After PWM is asserted high signal, M1 becomes ON and shifts to normal operation.

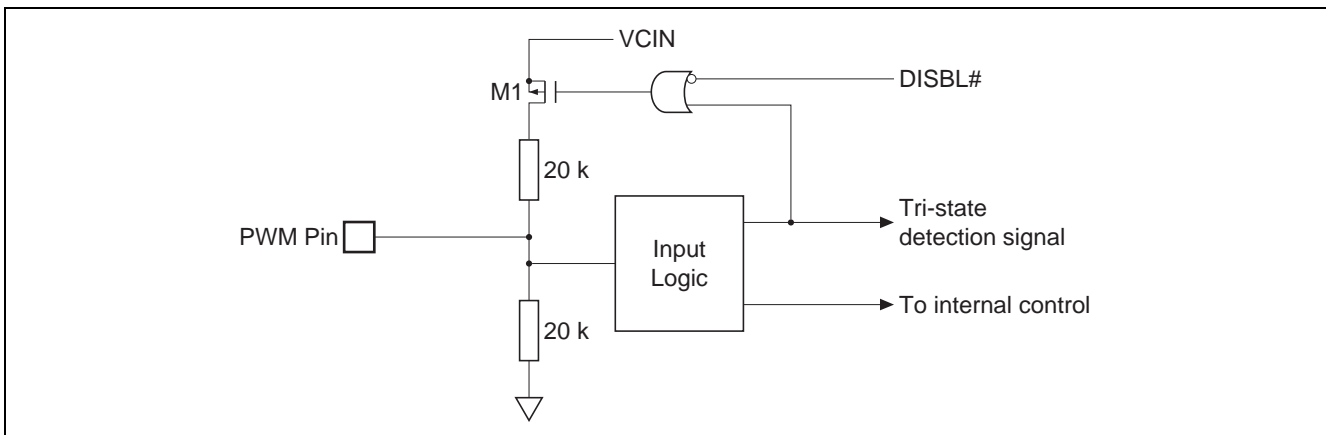

Figure 3 Equivalent Circuit for the PWM-pin Input

THWN

This thermal warning feature is the indication of the high temperature status.

THWN is an open drain logic output signal and need to connect a pull-up resistor (ex. 51 kΩ) to THWN for systems with the thermal warning implementation.

When the chip temperature of the internal driver IC becomes over 130°C, thermal warning function operates.

This signal is only indication for the system controller and does not disable DrMOS operation.

When thermal warning function is not used, keep this pin open.

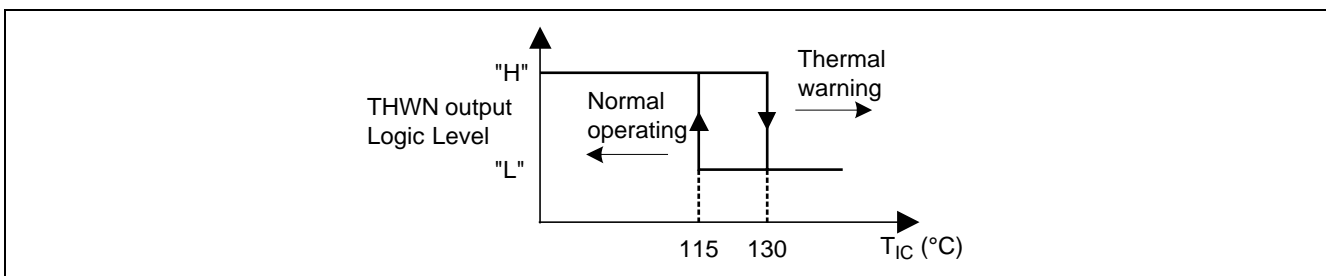

Figure 4

MOS FETs

The MOS FETs incorporated in R2J20651ANP are highly suitable for synchronous-rectification buck conversion. For the high-side MOS FET, the drain is connected to the VIN pin and the source is connected to the VSWH pin. For the low-side MOS FET, the drain is connected to the VSWH pin and the source is connected to the PGND pin.

PCB Layout Example

Figure 5 shows an example of the PCB layout for the R2J20651ANP. Placing several ceramic capacitors (e.g. 10 μF) between VIN and PGND can be expected to decrease switching noise and improve efficiency.

In that case, it is necessary to connect each GND pattern with low impedance by using other PCB layers.

Moreover, by taking the wide VSWH pattern, the effect of letting the heat from the low side MOS FET can be expected.

When R2J20651ANP is mounted on a small substrate like POL module, the temperature rising of the device could be eased if the thermal via-hole is added under the pad of VIN and VSWH.

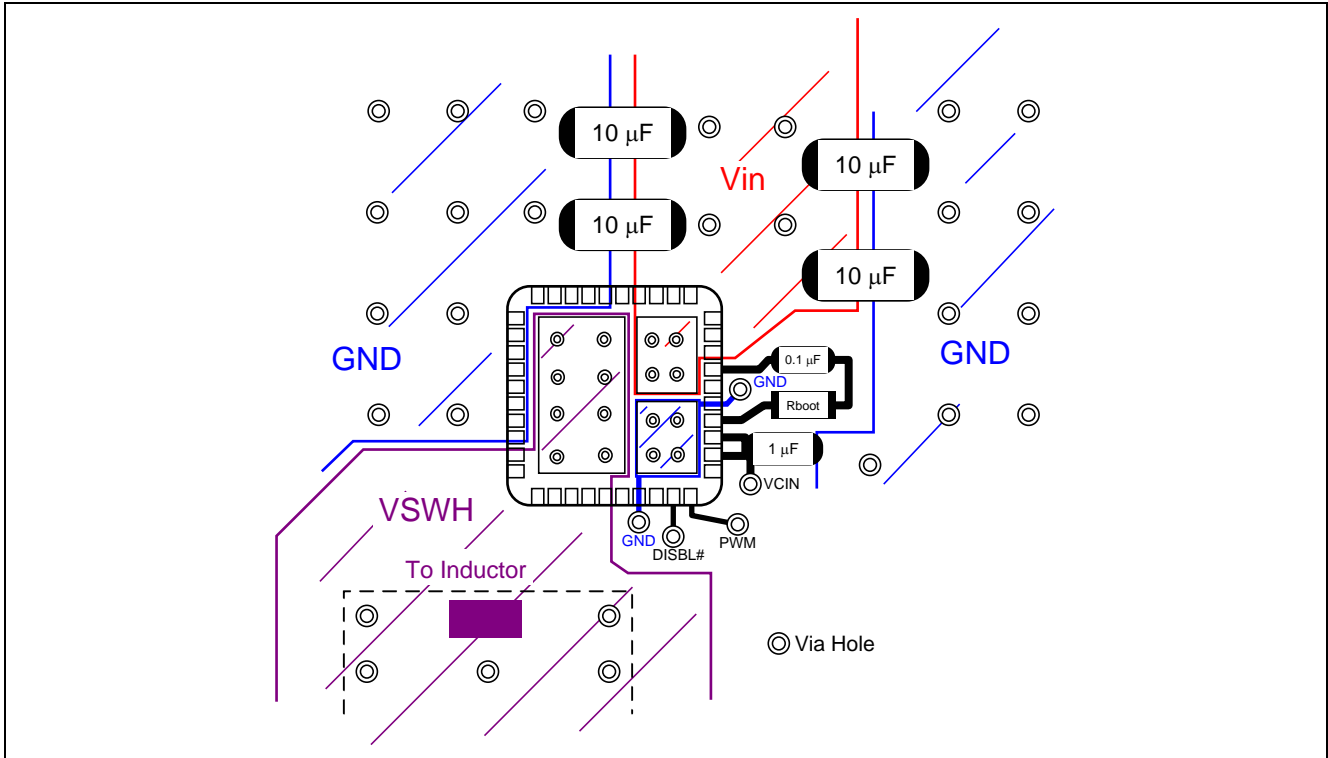

Figure 5 R2J20651ANP PCB Layout Example (Top View)

Footprint Example

(Unit: mm)

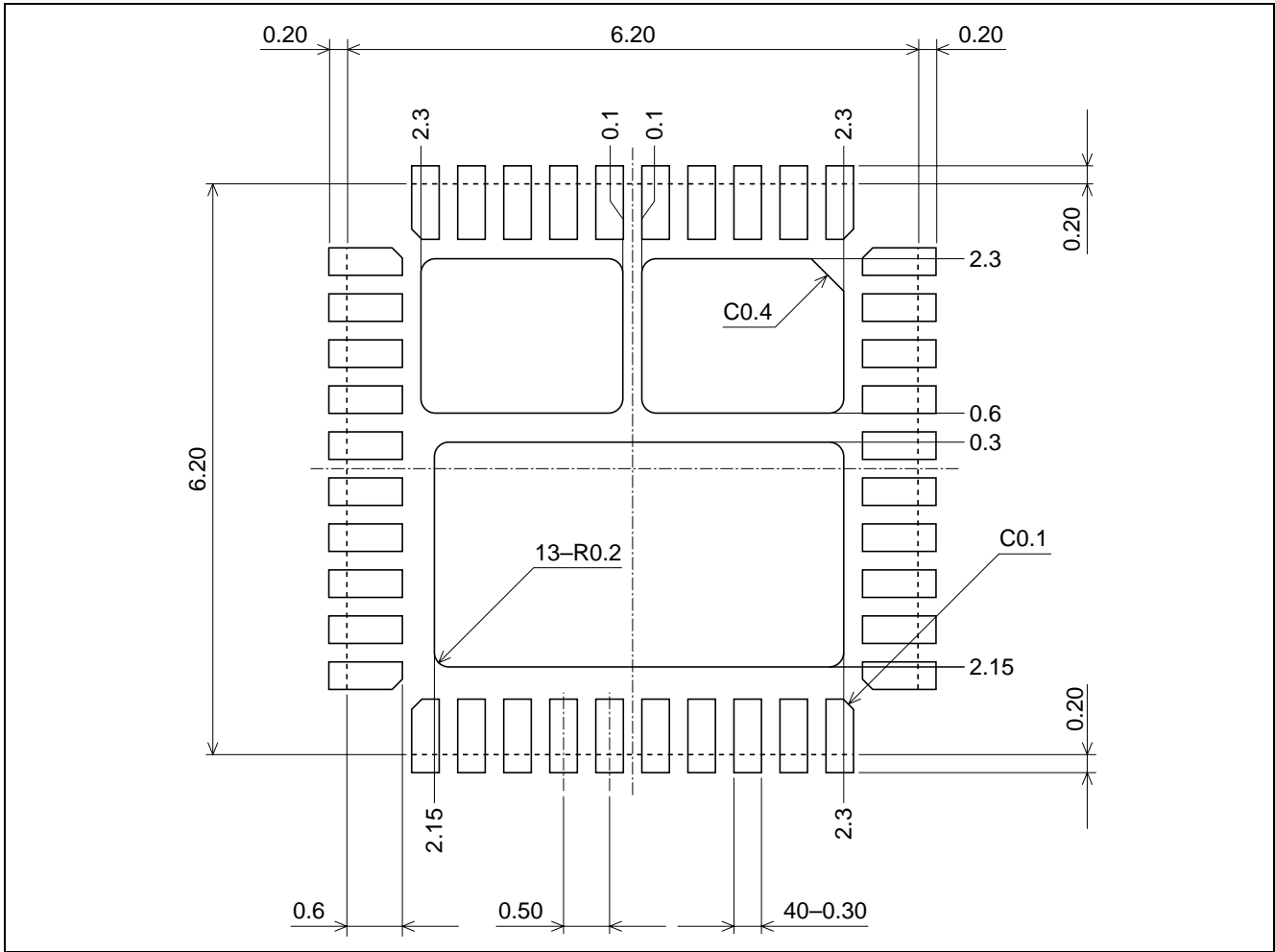
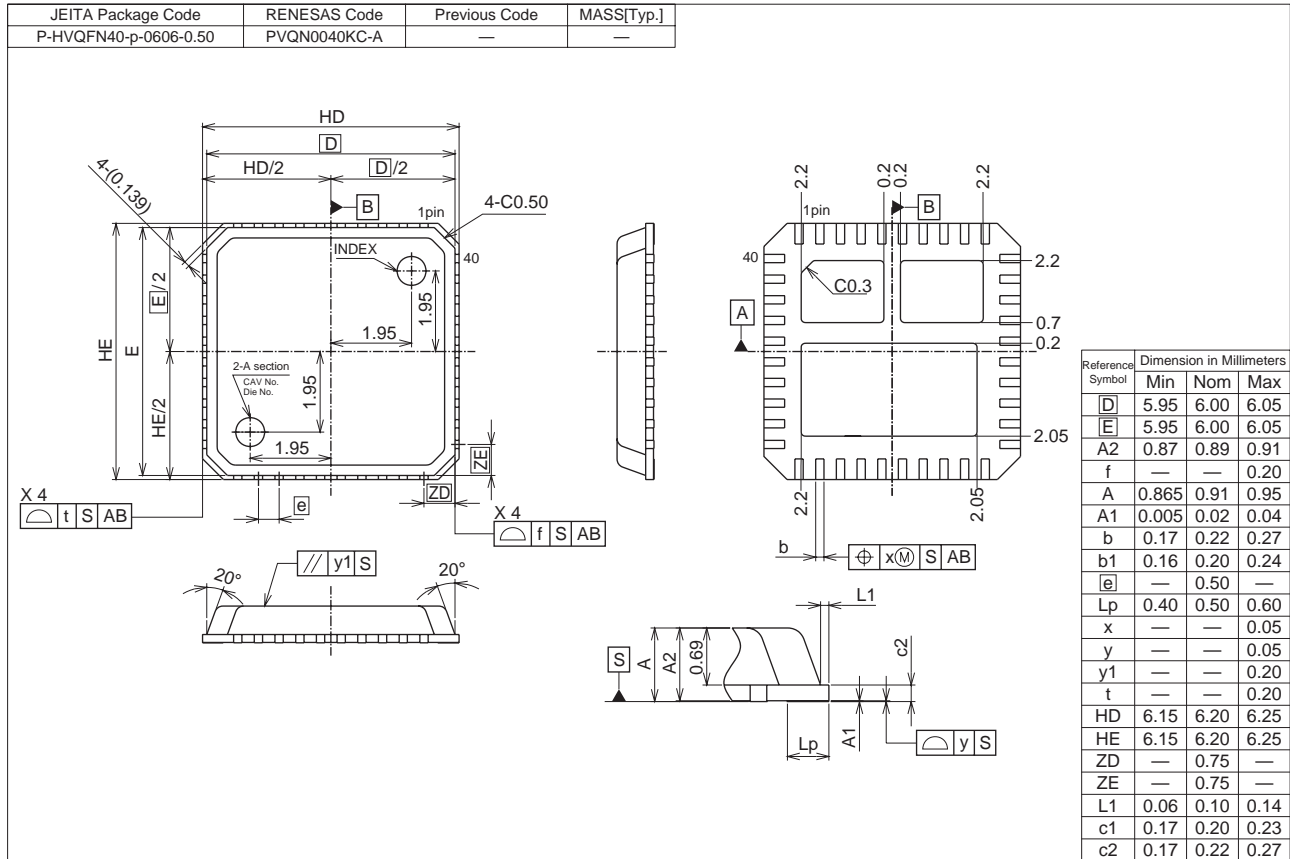

Figure 6 Footprint Example

Package Dimensions



Ordering Information

Part Name	Quantity	Shipping Container
R2J20651ANP#G3	2500 pcs	Taping Reel
R2J20651ANP#13	250 pcs	Tray

Notes:

1. This document is provided for reference purposes only so that Renesas customers may select the appropriate Renesas products for their use. Renesas neither makes warranties or representations with respect to the accuracy or completeness of the information contained in this document nor grants any license to any intellectual property rights or any other rights of Renesas or any third party with respect to the information in this document.
2. Renesas shall have no liability for damages or infringement of any intellectual property or other rights arising out of the use of any information in this document, including, but not limited to, product data, diagrams, charts, programs, algorithms, and application circuit examples.
3. You should not use the products or the technology described in this document for the purpose of military applications such as the development of weapons of mass destruction or for the purpose of any other military use. When exporting the products or technology described herein, you should follow the applicable export control laws and regulations, and procedures required by such laws and regulations.
4. All information included in this document such as product data, diagrams, charts, programs, algorithms, and application circuit examples, is current as of the date this document is issued. Such information, however, is subject to change without any prior notice. Before purchasing or using any Renesas products listed in this document, please confirm the latest product information with a Renesas sales office. Also, please pay regular and careful attention to additional and different information to be disclosed by Renesas such as that disclosed through our website. (<http://www.renesas.com>)
5. Renesas has used reasonable care in compiling the information included in this document, but Renesas assumes no liability whatsoever for any damages incurred as a result of errors or omissions in the information included in this document.
6. When using or otherwise relying on the information in this document, you should evaluate the information in light of the total system before deciding about the applicability of such information to the intended application. Renesas makes no representations, warranties or guarantees regarding the suitability of its products for any particular application and specifically disclaims any liability arising out of the application and use of the information in this document or Renesas products.
7. With the exception of products specified by Renesas as suitable for automobile applications, Renesas products are not designed, manufactured or tested for applications or otherwise in systems the failure or malfunction of which may cause a direct threat to human life or create a risk of human injury or which require especially high quality and reliability such as safety systems, or equipment or systems for transportation and traffic, healthcare, combustion control, aerospace and aeronautics, nuclear power, or undersea communication transmission. If you are considering the use of our products for such purposes, please contact a Renesas sales office beforehand. Renesas shall have no liability for damages arising out of the uses set forth above.
8. Notwithstanding the preceding paragraph, you should not use Renesas products for the purposes listed below:
 - (1) artificial life support devices or systems
 - (2) surgical implantations
 - (3) healthcare intervention (e.g., excision, administration of medication, etc.)
 - (4) any other purposes that pose a direct threat to human lifeRenesas shall have no liability for damages arising out of the uses set forth in the above and purchasers who elect to use Renesas products in any of the foregoing applications shall indemnify and hold harmless Renesas Technology Corp., its affiliated companies and their officers, directors, and employees against any and all damages arising out of such applications.
9. You should use the products described herein within the range specified by Renesas, especially with respect to the maximum rating, operating supply voltage range, movement power voltage range, heat radiation characteristics, installation and other product characteristics. Renesas shall have no liability for malfunctions or damages arising out of the use of Renesas products beyond such specified ranges.
10. Although Renesas endeavors to improve the quality and reliability of its products, IC products have specific characteristics such as the occurrence of failure at a certain rate and malfunctions under certain use conditions. Please be sure to implement safety measures to guard against the possibility of physical injury, and injury or damage caused by fire in the event of the failure of a Renesas product, such as safety design for hardware and software including but not limited to redundancy, fire control and malfunction prevention, appropriate treatment for aging degradation or any other applicable measures. Among others, since the evaluation of microcomputer software alone is very difficult, please evaluate the safety of the final products or system manufactured by you.
11. In case Renesas products listed in this document are detached from the products to which the Renesas products are attached or affixed, the risk of accident such as swallowing by infants and small children is very high. You should implement safety measures so that Renesas products may not be easily detached from your products. Renesas shall have no liability for damages arising out of such detachment.
12. This document may not be reproduced or duplicated, in any form, in whole or in part, without prior written approval from Renesas.
13. Please contact a Renesas sales office if you have any questions regarding the information contained in this document, Renesas semiconductor products, or if you have any other inquiries.



RENESAS SALES OFFICES

<http://www.renesas.com>

Refer to "<http://www.renesas.com/en/network>" for the latest and detailed information.

Renesas Technology America, Inc.
450 Holger Way, San Jose, CA 95134-1368, U.S.A
Tel: <1> (408) 382-7500, Fax: <1> (408) 382-7501

Renesas Technology Europe Limited
Dukes Meadow, Millboard Road, Bourne End, Buckinghamshire, SL8 5FH, U.K.
Tel: <44> (1628) 585-100, Fax: <44> (1628) 585-900

Renesas Technology (Shanghai) Co., Ltd.
Unit 204, 205, AZIACenter, No.1233 Lujiazui Ring Rd, Pudong District, Shanghai, China 200120
Tel: <86> (21) 5877-1818, Fax: <86> (21) 6887-7858/7898

Renesas Technology Hong Kong Ltd.
7th Floor, North Tower, World Finance Centre, Harbour City, Canton Road, Tsimshatsui, Kowloon, Hong Kong
Tel: <852> 2265-6688, Fax: <852> 2377-3473

Renesas Technology Taiwan Co., Ltd.
10th Floor, No.99, Fushing North Road, Taipei, Taiwan
Tel: <886> (2) 2715-2888, Fax: <886> (2) 3518-3399

Renesas Technology Singapore Pte. Ltd.
1 Harbour Front Avenue, #06-10, Keppel Bay Tower, Singapore 098632
Tel: <65> 6213-0200, Fax: <65> 6278-8001

Renesas Technology Korea Co., Ltd.
Kukje Center Bldg. 18th Fl., 191, 2-ka, Hangang-ro, Yongsan-ku, Seoul 140-702, Korea
Tel: <82> (2) 796-3115, Fax: <82> (2) 796-2145

Renesas Technology Malaysia Sdn. Bhd
Unit 906, Block B, Menara Amcorp, Amcorp Trade Centre, No.18, Jln Persiaran Barat, 46050 Petaling Jaya, Selangor Darul Ehsan, Malaysia
Tel: <603> 7955-9390, Fax: <603> 7955-9510