

STRUCTURE SILICON MONOLITHIC INTEGRATED CIRCUIT

FUNCTION INPUT/OUTPUT FULL SWING SINGLE CMOS OPERATIONAL AMPLIFIER

PRODUCT SERIES **BU7265G**  
**BU7265SG**

FEATURES

- Wide operating temperature range (BU7265SG : -40[°C] ~105[°C])
- Low input bias current(1[pA] typ.)
- Slew Rate(2.4[V/ms] typ.)
- Low supply current(0.35[μA] typ.)
- Wide input and output voltage range(VSS~VDD)
- Low power supply voltage operation(1.8[V]~5.5[V])

○ABSOLUTE MAXIMUM RATINGS(Ta=25[°C])

Parameter	Symbol	Rating	Unit
Supply Voltage	VDD-VSS	+7	V
Power dissipation	Pd	540 (*1) (*2)	mW
Differential Input Voltage(*3)	Vid	VDD-VSS	V
Input Common-mode Voltage Range	Vicm	(VSS-0.3) ~VDD+0.3	V
Operating Temperature range	Topr	BU7265	-40~+85
		BU7265S	-40~+105
Storage Temperature Range	Tstg	-55~+125	°C
Maximum junction Temperature	Tjmax	+125	°C

• This IC is not designed for protection against radioactive rays.

(\*1) To use at temperature above Ta=25[°C] reduce 5.4[mW].

(\*2) Mounted on a glass epoxy PCB (70[mm] × 70[mm] × 1.6[mm]).

(\*3) The voltage difference between inverting input and non-inverting input is the differential input voltage. Then input terminal voltage is set to more than VSS.

○OPERATING CONDITION (BU7265G: Ta=-40[°C] ~+85[°C] BU7265SG: Ta=-40[°C] ~+105[°C])

Parameter	Symbol	Rating	Unit
Supply Voltage	VDD	+1.8~+5.5 (Single Supply)	V

## ○ELECTRICAL CHARACTERISTICS (unless otherwise specified VDD=+3[V], VSS=0[V])

Parameter	Symbol	Temperature range	Guaranteed Limit			Unit	Condition
			Min.	Typ.	Max.		
Input offset voltage(*4)	V <sub>io</sub>	25°C	-	1	8.5	mV	
Input offset current(*4)	I <sub>io</sub>	25°C	-	1	-	pA	
Input bias current(*4)	I <sub>b</sub>	25°C	-	1	-	pA	
Supply current(*6)	I <sub>DD</sub>	25°C	-	0.35	0.9	μA	R <sub>L</sub> =∞ All Op-Amps AV=0[dB], V <sub>IN</sub> =1.5[V]
		Full range	-	-	1.3		
High level output voltage	V <sub>OH</sub>	25°C	V <sub>DD</sub> -0.1	-	-	V	R <sub>L</sub> =10[kΩ]
Low level output voltage	V <sub>OL</sub>	25°C	-	-	V <sub>SS</sub> +0.1	V	R <sub>L</sub> =10[kΩ]
Large signal voltage gain	A <sub>V</sub>	25°C	60	95	-	dB	R <sub>L</sub> =10[kΩ]
Input common mode voltage	V <sub>icm</sub>	25°C	0	-	3	V	V <sub>SS</sub> ~V <sub>DD</sub>
Common mode rejection ratio	CMRR	25°C	45	60	-	dB	
Power supply rejection ratio	PSRR	25°C	60	80	-	dB	
Output source current(*5)	I <sub>OH</sub>	25°C	1	2.4	-	mA	V <sub>DD</sub> -0.4[V]
Output sink current(*5)	I <sub>OL</sub>	25°C	2	4	-	mA	V <sub>SS</sub> +0.4[V]
Slew rate	SR	25°C	-	2.4	-	V/ms	C <sub>L</sub> =25[pF]
Gain band width	FT	25°C	-	4	-	kHz	C <sub>L</sub> =25[pF], AV=40[dB]
Phase margin	θ	25°C	-	60°	-		C <sub>L</sub> =25[pF], AV=40[dB]

(\*4) Absolute value

 (\*5) Reference to power dissipation under the high temperature environment and decide the output current.  
 Continuous short circuit is occurring the degenerate of output current characteristics.

(\*6) Full range BU7265:-40[°C]~+85[°C] BU7265S:-40[°C]~+105[°C]

○Physical Dimensions

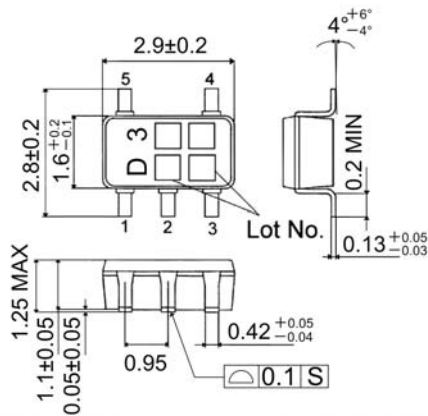

BU7265G (SSOP5) (Unit : [mm])

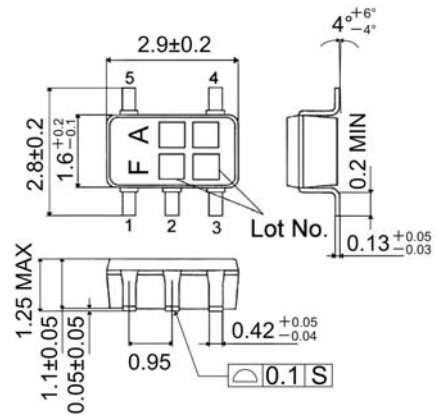

BU7265SG (SSOP5) (Unit : [mm])

○Block diagram

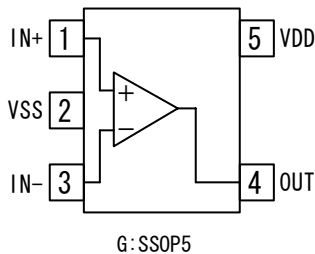

○Pin No. · Pin Name

Pin No.	Pin Name
1	IN+
2	VSS
3	IN-
4	OUT
5	VDD

○Application example

(1) Absolute maximum ratings

Absolute maximum ratings are the values which indicate the limits, within which the given voltage range can be safely charged to the terminal. However, it does not guarantee the circuit operation.

(2) Applied voltage to the input terminal

For normal circuit operation of operational amplifier, please input voltage for its input terminal within input common mode voltage  $VDD+0.3[V]$ . Then, regardless of power supply voltage,  $VSS-0.3[V]$  can be applied to input terminals without deterioration or destruction of its characteristics.

(3) Operating power supply (split power supply/single power supply)

The operational amplifier operates if a given level of voltage is applied between VDD and VSS. Therefore, the operational amplifier can be operated under single power supply or split power supply.

(4) Power dissipation (pd)

If the IC is used under excessive power dissipation. An increase in the chip temperature will cause deterioration of the radical characteristics of IC. For example, reduction of current capability. Take consideration of the effective power dissipation and thermal design with a sufficient margin. Pd is reference to the provided power dissipation curve.

(5) Short circuits between pins and incorrect mounting

Short circuits between pins and incorrect mounting when mounting the IC on a printed circuits board, take notice of the direction and positioning of the IC. If IC is mounted erroneously, It may be damaged. Also, when a foreign object is inserted between output, between output and VDD terminal or VSS terminal which causes short circuit, the IC may be damaged.

- (6) Output short circuit  
If short circuit occurs between the output terminal and VDD terminal, excessive in output current may flow and generate heat, causing destruction of the IC. Take due care.
- (7) Using under strong electromagnetic field  
Be careful when using the IC under strong electromagnetic field because it may malfunction.
- (8) Usage of IC  
When stress is applied to the IC through warp of the printed circuit board, The characteristics may fluctuate due to the piezo effect.  
Be careful of the warp of the printed circuit board.
- (9) Testing IC on the set board  
When testing IC on the set board, in cases where the capacitor is connected to the low impedance, make sure to discharge per fabrication because there is a possibility that IC may be damaged by stress. When removing IC from the set board, it is essential to cut supply voltage.  
As a countermeasure against the static electricity, observe proper grounding during fabrication process and take due care when carrying and storage it.
- (10) The IC destruction caused by capacitive load  
The transistors in circuits may be damaged when VDD terminal and VSS terminal is shorted with the charged output terminal capacitor.  
When IC is used as a operational amplifier or as an application circuit, where oscillation is not activated by an output capacitor, the output capacitor must be kept below  $0.1[\mu\text{F}]$  in order to prevent the damage mentioned above.
- (11) Decoupling capacitor  
Insert the decoupling capacitance between VDD and VSS, for stable operation of operational amplifier.
- (12) Latch up  
Be careful of input voltage that exceed the VDD and VSS. When CMOS device have sometimes occur latch up operation. And protect the IC from abnormally noise
- (13) Crossover distortion  
Inverting amplifier is generate crossover distortion when feed back resistance value is small.  
To suppress the crossover distortion, connect a resistor between the output terminal and VSS  
Then increase the bias current to enable class A output stage operation.

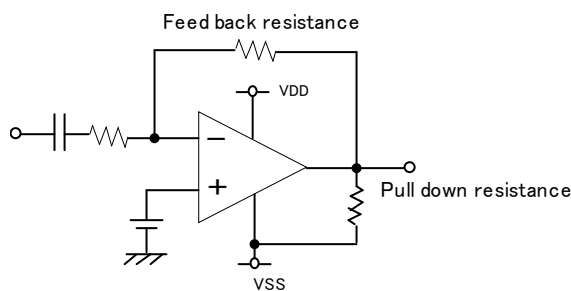

Fig1.Pull down resistance

## Notes

No copying or reproduction of this document, in part or in whole, is permitted without the consent of ROHM Co.,Ltd.

The content specified herein is subject to change for improvement without notice.

The content specified herein is for the purpose of introducing ROHM's products (hereinafter "Products"). If you wish to use any such Product, please be sure to refer to the specifications, which can be obtained from ROHM upon request.

Examples of application circuits, circuit constants and any other information contained herein illustrate the standard usage and operations of the Products. The peripheral conditions must be taken into account when designing circuits for mass production.

Great care was taken in ensuring the accuracy of the information specified in this document. However, should you incur any damage arising from any inaccuracy or misprint of such information, ROHM shall bear no responsibility for such damage.

The technical information specified herein is intended only to show the typical functions of and examples of application circuits for the Products. ROHM does not grant you, explicitly or implicitly, any license to use or exercise intellectual property or other rights held by ROHM and other parties. ROHM shall bear no responsibility whatsoever for any dispute arising from the use of such technical information.

The Products specified in this document are intended to be used with general-use electronic equipment or devices (such as audio visual equipment, office-automation equipment, communication devices, electronic appliances and amusement devices).

The Products specified in this document are not designed to be radiation tolerant.

While ROHM always makes efforts to enhance the quality and reliability of its Products, a Product may fail or malfunction for a variety of reasons.

Please be sure to implement in your equipment using the Products safety measures to guard against the possibility of physical injury, fire or any other damage caused in the event of the failure of any Product, such as derating, redundancy, fire control and fail-safe designs. ROHM shall bear no responsibility whatsoever for your use of any Product outside of the prescribed scope or not in accordance with the instruction manual.

The Products are not designed or manufactured to be used with any equipment, device or system which requires an extremely high level of reliability the failure or malfunction of which may result in a direct threat to human life or create a risk of human injury (such as a medical instrument, transportation equipment, aerospace machinery, nuclear-reactor controller, fuel-controller or other safety device). ROHM shall bear no responsibility in any way for use of any of the Products for the above special purposes. If a Product is intended to be used for any such special purpose, please contact a ROHM sales representative before purchasing.

If you intend to export or ship overseas any Product or technology specified herein that may be controlled under the Foreign Exchange and the Foreign Trade Law, you will be required to obtain a license or permit under the Law.



Thank you for your accessing to ROHM product informations.  
More detail product informations and catalogs are available, please contact us.

## ROHM Customer Support System

<http://www.rohm.com/contact/>