

Low Power Low Offset Quad Comparators

DIP-14



SOP-14



Pin Definition:

- | | |
|----------------|-----------------|
| 1. Output 2 | 14. Output 3 |
| 2. Output 1 | 13. Output 4 |
| 3. Vcc | 12. Gnd |
| 4. Input 1 (-) | 11. Input 4 (+) |
| 5. Input 1 (+) | 10. Input 4 (-) |
| 6. Input 2 (-) | 9. Input 3 (+) |
| 7. Input 2 (+) | 8. Input 3 (-) |

General Description

The TS339 is quad independent precision voltage comparators capable of single-supply or split-supply operation. The specifications as low as 2.0 mV make this device an excellent ground level with single-supply operation. Input offset-voltage selection for many applications in consumer automotive, and It is designed to permit a common mode range-to- industrial electronics.

Features

- Low input bias current: 25nA (Typ)
- Low input offset current: ±5nA (Typ)
- Low input offset voltage
- Input common mode voltage range to GND
- Low output saturation voltage: 130mV (Typ)
- TTL and CMOS compatible

Block Diagram

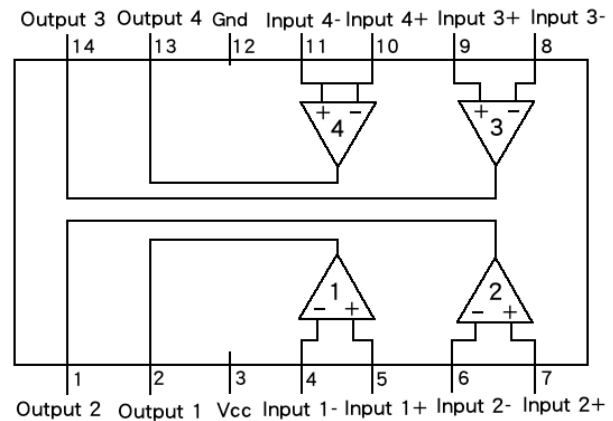

Ordering Information

Part No.	Package	Packing
TS339CD14 C4	DIP-14	50pcs / Tube
TS339CS14 RL	SOP-14	2.5Kpcs / 13" Reel

Absolute Maximum Rating

Parameter	Symbol	Limit	Unit
Supply Voltage	V _{CC}	+36 or ±18	V
Differential Input Voltage	V _{IDR}	36	V
Input Common Mode Voltage Range	V _{ICR}	-0.3 to 36	V
Input Current	I _{IN}	50	mA
Output Short Circuit Duration (note 1)	t _{SC}	Continuous	
Operating Temperature Range	T _{OPR}	0 ~ +70	°C
Junction Temperature	T _J	+150	°C
Storage Temperature Range	T _{STG}	-65 ~ +150	°C

Maximum ratings are those values beyond which device damage can occur. Maximum ratings applied to the device are individual stress limit values (not normal operating conditions) and are not valid simultaneously. If these limits are exceeded, device functional operation is not implied, damage may occur and reliability may be affected.

Note 1. The maximum output current may be as high as 20mA, independent of the magnitude of V_{CC} Output short circuits to V_{CC} can cause excessive heating and eventual destruction

Electrical Characteristics ($V_{CC} = 5V$, $T_a = 25^\circ C$; unless otherwise specified.)

Characteristics	Symbol	Min.	Typ.	Max.	Unit
Input Offset Voltage (note 2)	V_{IO}	--	± 2.0	± 5.0	mV
Input Offset Current (note 2)	I_{IO}	--	± 5.0	± 50	nA
Input Bias Current (note 2, 3) (Output in linear range)	I_{IB}		25	250	nA
Input Common-Mode Voltage Range (note 4)	V_{ICR}	0	--	$V_{CC} - 1.5$	V
Voltage Gain $R_L \geq 15K$, $V_{CC} = 15V$	A_{VOL}	50	200	--	V/mV
Large Signal Response Time $V_{in} = \text{TTL Logic Swing}$. $V_{ref} = 1.4V$, $V_{RL} = 5V$. $R_L = 5.1K\Omega$	--	--	300	--	nS
Response Time (note 4) $V_{RL} = 5V$. $R_L = 5.1K\Omega$	--	--	1.3	--	μS
Output Sink Current	I_{SINK}	6.0	16	--	mA
Saturation Voltage $V_{I(+)} \geq +1V$, $V_{I(-)} = 0$, $V_O = +5V$	V_{SAT}	--	130	400	mV
Output Leakage Current $V_{ID} = +1.0V$, $V_{CC} = 15V$	I_{OL}	--	0.1	--	nA
Supply Current $R_L = \infty$ (For All Comparators) $R_L = \infty$, $V_{CC} = 30V$	I_{CC}	--	0.8 1.0	2.0 2.5	mA

Notes:

1. TS339: $T_{LOW} = 0^\circ C$, $T_{HIGH} = +70^\circ C$
2. At the output switch point, $V_O = 1.4V_{dc}$, $R_S \leq 100\Omega$, $5.0V_{dc} \leq V_{CC} \leq 30V_{dc}$, with the inputs over the full common-mode range ($0V_{dc}$ to $V_{CC} - 1.5V_{dc}$).
3. The bias current flows out of the inputs due to the PNP input stage. This current is virtually constant, independent of the output state.
4. The response time specified is for a 100mV input step with 5mV overdrive. For larger signals, 300ns is typical.
5. Positive excursions of input voltage may exceed the power supply level. As long as one of the inputs remain within the common-mode range, the comparator will provide the proper output state.
6. The comparator will inhibit proper output state if one of the inputs is become greater than V_{CC} , the other input must remain within the common mode range. The low input state must not be less than -0.3volts of ground of minus supply.

Electrical Characteristics Curve

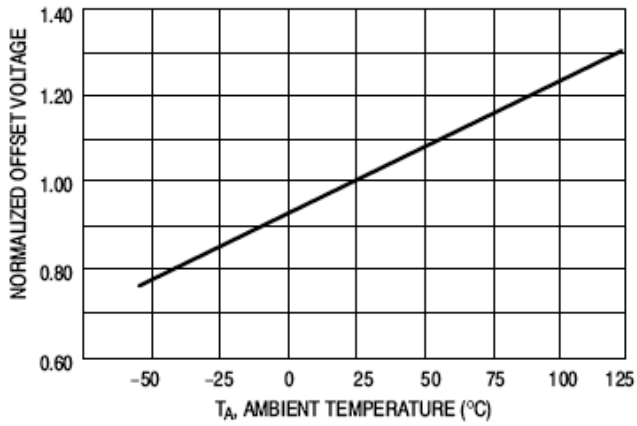

Figure 1. Normalized Input Offset Voltage

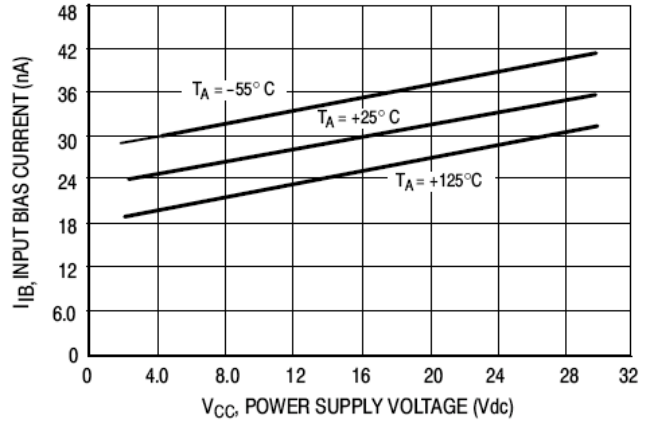

Figure 2. Input Bias Current

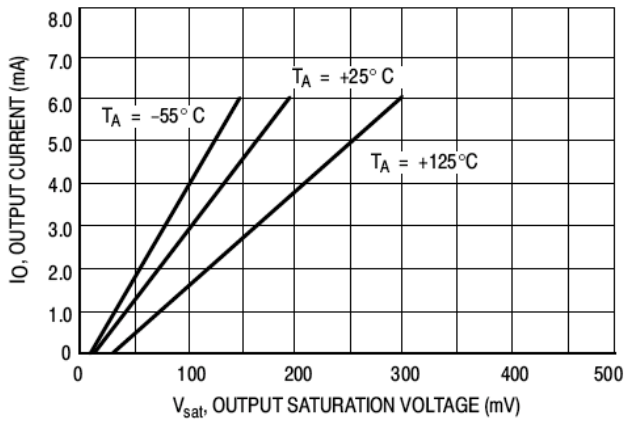

Figure 3. Output Sink Current vs. Out Saturation Voltage

Low Power Low Offset Quad Comparators

Application Description

This quad comparator feature high gain, wide bandwidth characteristics. This gives the device oscillation tendencies if the outputs are capacitive coupled to the inputs via stray capacitance. This oscillation manifests itself during output transitions (VOL to VOH). To alleviate this situation input resistors <math><10K\Omega</math> should be used. The addition of positive feedback (<math><10\text{ mV}</math>) is also recommended.

It is good design practice to ground all unused pins. Differential input voltages may be larger than supply voltage without damaging the comparator's inputs. Voltages more negative than -0.3V should not be used.

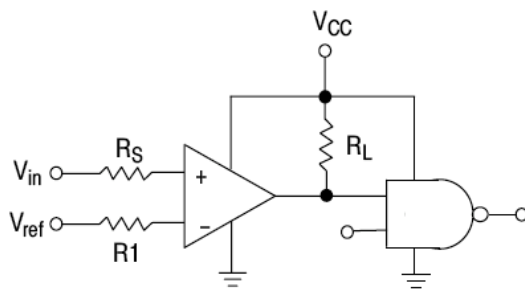

R_S = Source Resistance
 $R_1 \approx R_S$

Logic	Device	V _{CC} (V)	R _L kΩ
CMOS	1/4 MC14001	+15	100
TTL	1/4 MC7400	+5.0	10

Figure 4. Driving Logic

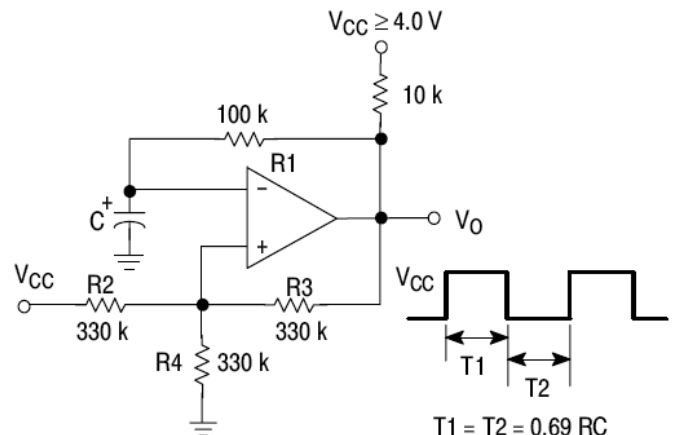

$T_1 = T_2 = 0.69 RC$

$f \approx \frac{7.2}{C(\mu F)}$

$R_2 = R_3 = R_4$

$R_1 \approx R_2 // R_3 // R_4$

Figure 5. Squarewave Oscillator

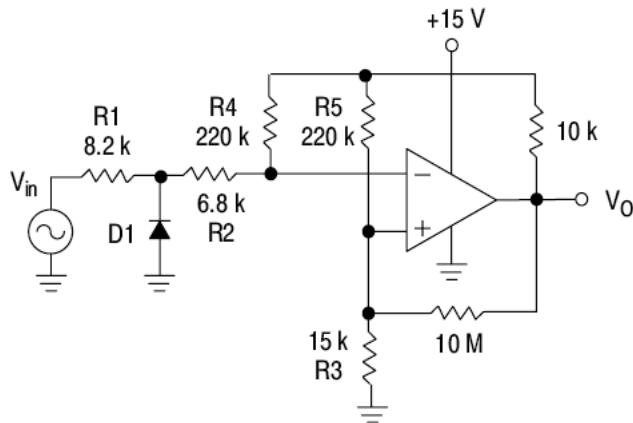

D1 prevents input from going negative by more than 0.6 V.

$R_1 + R_2 = R_3$

$R_3 \leq \frac{R_5}{10}$ for small error in zero crossing

Figure 6. Zero Crossing Detector (Single Supply)

$V_{in(min)} \approx 0.4\text{ V}$ peak for 1% phase distortion ($\Delta\theta$).

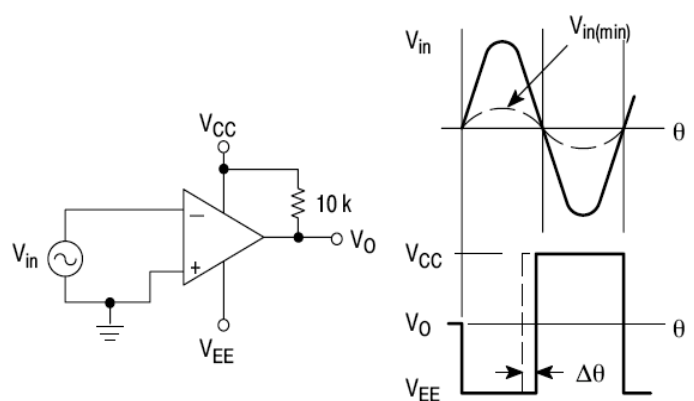
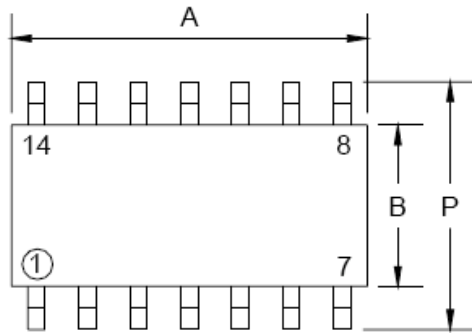
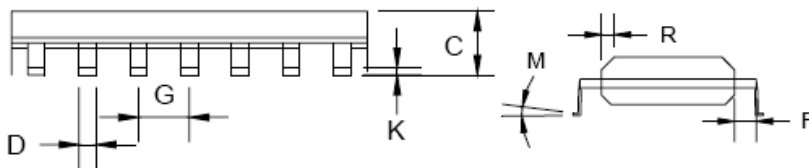

Figure 7. Zero Crossing Detector (Split Supplies)

SOP-14 Mechanical Drawing



SOP-14 DIMENSION				
DIM	MILLIMETERS		INCHES	
	MIN	MAX	MIN	MAX
A	8.55	8.75	0.337	0.344
B	3.80	4.00	0.150	0.157
C	1.35	1.75	0.054	0.068
D	0.35	0.49	0.014	0.019
F	0.40	1.25	0.016	0.049
G	1.27 (typ)		0.05 (typ)	
K	0.10	0.25	0.004	0.009
M	0°	7°	0°	7°
P	5.80	6.20	0.229	0.244
R	0.25	0.50	0.010	0.019



Marking Diagram

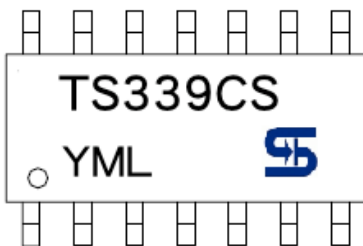

- Y** = Year Code
- M** = Month Code
(A=Jan, B=Feb, C=Mar, D=Apl, E=May, F=Jun, G=Jul, H=Aug, I=Sep, J=Oct, K=Nov, L=Dec)
- L** = Lot Code

DIP-14 Mechanical Drawing

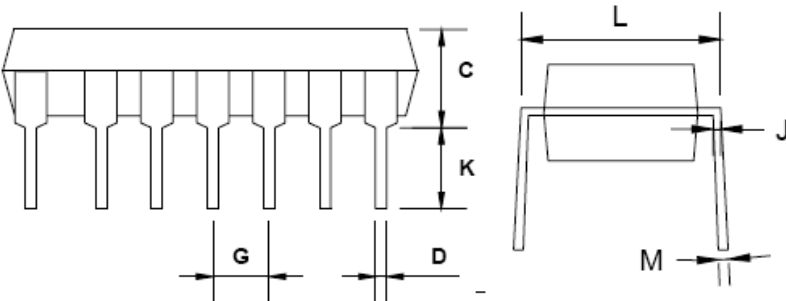
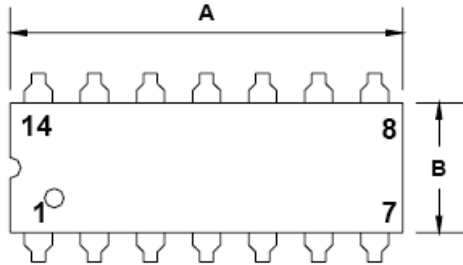

DIP-14 DIMENSION				
DIM	MILLIMETERS		INCHES	
	MIN	MAX	MIN	MAX
A	18.55	19.56	0.730	0.770
B	6.22	6.48	0.245	0.255
C	3.18	4.45	0.125	0.135
D	0.35	0.55	0.019	0.020
G	2.54 (typ)		0.10 (typ)	
J	0.29	0.31	0.011	0.012
K	3.25	3.35	0.128	0.132
L	7.75	8.00	0.305	0.315
M	-	10°	-	10°

Marking Diagram



- Y** = Year Code
- M** = Month Code
(A=Jan, B=Feb, C=Mar, D=Apl, E=May, F=Jun, G=Jul, H=Aug, I=Sep, J=Oct, K=Nov, L=Dec)
- L** = Lot Code

Notice

Specifications of the products displayed herein are subject to change without notice. TSC or anyone on its behalf, assumes no responsibility or liability for any errors or inaccuracies.

Information contained herein is intended to provide a product description only. No license, express or implied, to any intellectual property rights is granted by this document. Except as provided in TSC's terms and conditions of sale for such products, TSC assumes no liability whatsoever, and disclaims any express or implied warranty, relating to sale and/or use of TSC products including liability or warranties relating to fitness for a particular purpose, merchantability, or infringement of any patent, copyright, or other intellectual property right.

The products shown herein are not designed for use in medical, life-saving, or life-sustaining applications. Customers using or selling these products for use in such applications do so at their own risk and agree to fully indemnify TSC for any damages resulting from such improper use or sale.