

## Series 804 Receptacles With PCB or Solder Cup Contacts



**Series 804 Printed  
Circuit Board Receptacle**

**Series 804 Receptacles** feature factory-installed non-removable contacts. Connectors are backfilled with rigid epoxy for a watertight seal.

**Series 804 QDC Receptacles** are available in two jam nut shell styles. **Style 00** for front panel mounting; and **Style 07** for rear panel mounting.

**PCB Contacts** feature .020" (0.5mm) diameter gold-plated tails for solder termination to rigid or flexible circuits.

**Solder Cup Contacts** accept up to #22 AWG stranded wire.

### HOW TO ORDER SERIES 801 PRINTED CIRCUIT BOARD RECEPTACLES

Sample Part Number						
804-005	-07	NF	9-4	E		
Series	Shell Style	Shell Material / Finish	Shell Size- Insert Arrangement	Contact Type	Shell Key Position	
<b>804-005</b> Receptacle with Solder Cup Contacts or PC Tails	 -00 Jam Nut, Front Panel	<b>C</b> Aluminum / Black Anodize	<b>5-3</b> 3 #23 <b>6-1</b> 1 #16 <b>6-4</b> 4 #23 <b>6-7</b> 7 #23	<b>P</b> Pin, PC Tail	<b>Omit</b> for Single Master Key	
		<b>M</b> Aluminum / Electroless Nickel	<b>7-1</b> 1 #12			
		<b>NF</b> Aluminum / Cadmium with Olive Drab Chromate	<b>7-10</b> 10 #23 <b>8-13</b> 13 #23			
		<b>ZN</b> Aluminum / Zinc-Nickel with Olive Drab Chromate	<b>9-4</b> 4 #16			
		<b>ZNU</b> Aluminum / Zinc-Nickel with Black Chromate	<b>9-19</b> 19 #23 <b>10-26</b> 26 #23			
		<b>Z1</b> Stainless Steel	<b>12-2</b> 2 #12 <b>12-37</b> 37 #23 <b>14-55</b> 55 #23 <b>15-85</b> 85 #23			
	 -07 Jam Nut, Rear Panel				<b>S</b> Socket, PC Tail	<b>A</b> Pos. A (Normal)
					<b>E</b> Pin, Solder Cup	<b>B</b> Pos. B
					<b>F</b> Socket, Solder Cup	<b>C</b> Pos. C
						<b>D</b> Pos. D

## Series 804 PCB/Solder Receptacles – Rear Panel Jam Nut

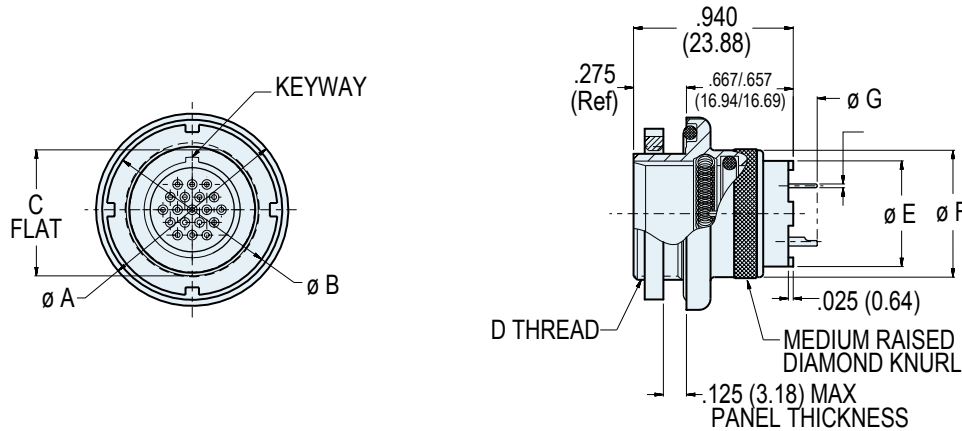

Rear Panel Jam Nut  
804-005-07

### DIMENSIONS

Shell Size	Ø A		Ø B		C Flat		D Threads	Ø E		Ø F		Ø G Tail Dia.
	In.	mm.	In.	mm.	In.	mm.		In.	mm.	In.	mm.	
5	.730	18.54	.562	14.27	.415	10.54	.4375-32 UN-2A	.244	6.20	.435	11.05	#23 .018/.022 (0.46/0.56)
6	.730	18.54	.625	15.87	.467	14.40	.5000-32 UN-2A	.330	8.38	.483	12.27	
7	.910	23.11	.750	19.05	.594	15.09	.6250-28 UN-2A	.432	10.97	.570	14.48	
8	.955	24.26	.750	19.05	.594	15.09	.6250-28 UN-2A	.493	12.52	.593	15.06	
9	1.000	25.40	.812	20.62	.655	16.64	.6875-28 UN-2A	.551	14.00	.685	17.40	
10	1.085	27.48	.875	22.22	.721	18.31	.7500-28 UN-2A	.620	15.75	.725	18.42	#12 .092/.096 (2.34/2.44)
12	1.190	30.23	1.000	25.40	.843	21.41	.8750-28 UN-2A	.703	17.86	.850	21.59	
14	1.325	33.66	1.125	28.57	.968	24.59	1.0000-28 UN-2A	.863	21.92	.973	24.71	
15	1.375	34.93	1.188	30.17	1.029	26.14	1.0625-20 UN-2A	.912	23.16	1.028	26.11	

### ALTERNATE KEY POSITIONS

Pos.	A°	B°
A	150°	210°
B	75°	210°
C	95°	230°
D	140°	275°

### JAM NUT PANEL CUTOUT

Shell Size	A Flat		Ø B	
	In. ± .002	mm. ± 0.05	In.	mm.
5	.425	10.80	.448	11.38
6	.477	12.12	.510	12.95
7	.604	15.34	.635	16.13
8	.604	15.34	.635	16.13
9	.665	16.89	.695	17.65
10	.731	18.57	.760	19.30
12	.853	21.67	.885	22.48
14	.978	24.84	1.010	25.65
15	1.039	26.39	1.070	27.18

## Series 804 PCB/Solder Receptacles – Front Panel Jam Nut

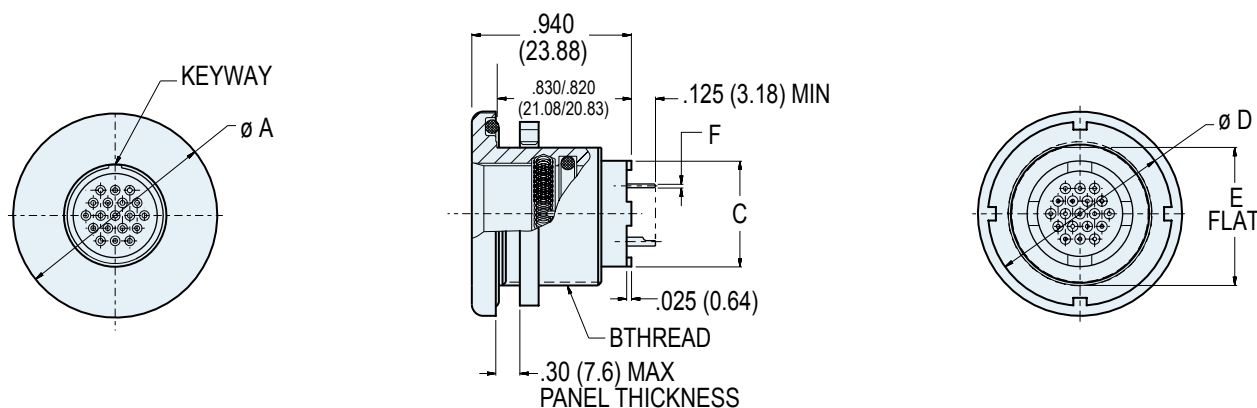

**Front Panel Jam Nut**  
804-005-00

### DIMENSIONS

Shell Size	Ø A		B Threads	Ø C		Ø E		E Flat		Ø F Tail Dia.
	In.	mm.		In.	mm.	In.	mm.	In.	mm.	
<b>5</b>	.830	21.08	.5000-32 UN-2A	.244	6.20	.625	15.87	.470	11.94	#23 .018/.022 (0.46/0.56)
<b>6</b>	.885	22.48	.5625-28 UN-2A	.330	8.38	.688	17.47	.530	13.46	
<b>7</b>	.995	25.27	.6875-28 UN-2A	.432	10.97	.812	20.62	.663	16.84	
<b>8</b>	.995	25.27	.6875-28 UN-2A	.493	12.52	.812	20.62	.663	16.84	#16 .060/.064 (1.52/1.63)
<b>9</b>	1.075	27.31	.7500-28 UN-2A	.551	14.00	.875	22.22	.720	18.29	
<b>10</b>	1.140	28.95	.8125-28 UN-2A	.620	15.75	.938	23.82	.788	20.02	#12 .092/.096 (2.34/2.44)
<b>12</b>	1.340	34.04	1.0000-28 UN-2A	.703	17.86	1.125	28.57	.970	24.64	
<b>14</b>	1.390	35.31	1.0625-20 UN-2A	.863	21.92	1.188	30.18	1.020	25.91	
<b>15</b>	1.450	36.83	1.1250-28 UN-2A	.912	23.16	1.250	31.75	1.093	27.76	

### ALTERNATE KEY POSITIONS

Pos.	A°	B°
A	150°	210°
B	75°	210°
C	95°	230°
D	140°	275°

### JAM NUT PANEL CUTOUT

Shell Size	A Flat		Ø B	
	In. ± .002	mm. ± 0.05	In.	mm.
<b>5</b>	.480	12.19	.510	12.95
<b>6</b>	.540	13.72	.575	14.61
<b>7</b>	.674	17.12	.698	17.73
<b>8</b>	.674	17.12	.698	17.73
<b>9</b>	.730	18.54	.760	19.30
<b>10</b>	.799	20.29	.822	20.88
<b>12</b>	.980	24.89	1.010	25.65
<b>14</b>	1.030	26.16	1.075	27.31
<b>15</b>	1.013	25.73	1.135	28.83