

Schottky Barrier Diode

SD101AWS/SD101BWS/SD101CWS

FEATURES

- Low Forward Voltage Drop.
- Guard Ring Construction For Transient Protection.
- Negligible Reverse Recovery Time.
- Low reverse capacitance.
- Ultra-small surface mount package.



Lead-free

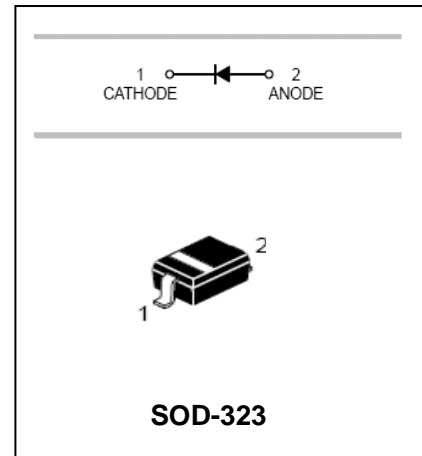

APPLICATIONS

- Schottky barrier switching.

ORDERING INFORMATION

Type No.	Marking	Package Code
SD101AWS	S1	SOD-323
SD101BWS	S2	SOD-323
SD101CWS	S3	SOD-323

MAXIMUM RATING @ Ta=25°C unless otherwise specified

Parameter	Symbol	SD101AW	SD101BW	SD101CW	Unit
Peak Repetitive Peak reverse voltage	V_{RRM}				
Working Peak DC Reverse Voltage	V_{RWM}	60	50	40	V
	V_R				
RMS Reverse Voltage	$V_{R(RMS)}$	42	35	28	V
Forward Continuous Current	I_F	15			mA
Repetitive Peak Forward Current @t<1.0s @t=10µs	I_{FRM}	50			mA
		2.0			A
Power Dissipation	P_d	200			mW
Thermal Resistance Junction to Ambient	$R_{\theta JA}$	625			°C/W
Storage temperature	T_{stg}	-65~+125			°C

Schottky Barrier Diode

SD101AWS/SD101BWS/SD101CWS

ELECTRICAL CHARACTERISTICS @ Ta=25°C unless otherwise specified

Parameter	Symbol	Min.	Typ.	Max.	Unit	Conditions
Reverse Breakdown Voltage	SD101AW SD101BW SD101CW	60 50 40			V	$I_R=10\mu A$ $I_R=10\mu A$ $I_R=10\mu A$
Forward voltage	SD101AW SD101BW SD101CW SD101AW SD101BW SD101CW			0.41 0.40 0.39 1.00 0.95 0.90	V	$I_F=1.0mA$ $I_F=1.0mA$ $I_F=1.0mA$ $I_F=15mA$ $I_F=15mA$ $I_F=15mA$
Reverse current	SD101AW SD101BW SD101CW			0.2	μA	$V_R=50V$ $V_R=40V$ $V_R=30V$
Capacitance between terminals	SD101AW SD101BW SD101CW			2.0 2.1 2.2	pF	$V_R=0, f=1MHz$
Reverse Recovery Time				1.0	ns	$I_R=I_F=5mA$ $I_{rr}=0.1 \cdot I_R, R_L=100\Omega$

TYPICAL CHARACTERISTICS @ Ta=25°C unless otherwise specified

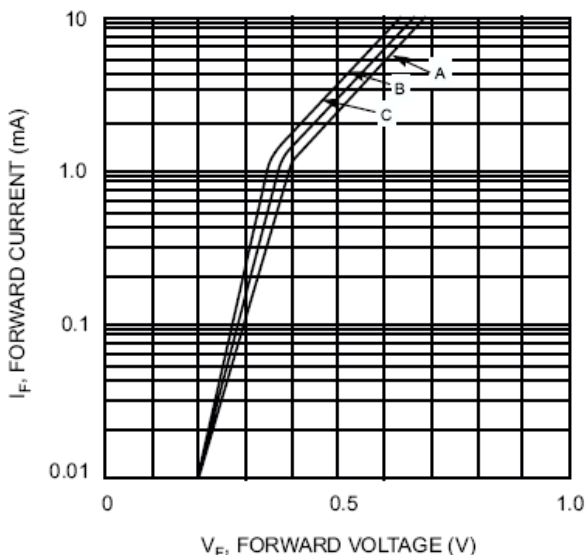

Fig. 1 Typical Forward Characteristic Variations for Primary Conduction

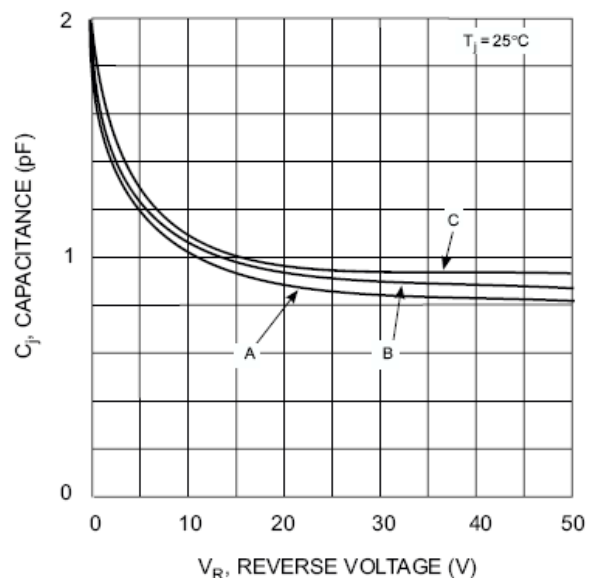

Fig. 2 Typ. Junction Capacitance vs Reverse Voltage

Schottky Barrier Diode

SD101AWS/SD101BWS/SD101CWS

PACKAGE OUTLINE

Plastic surface mounted package

SOD-323

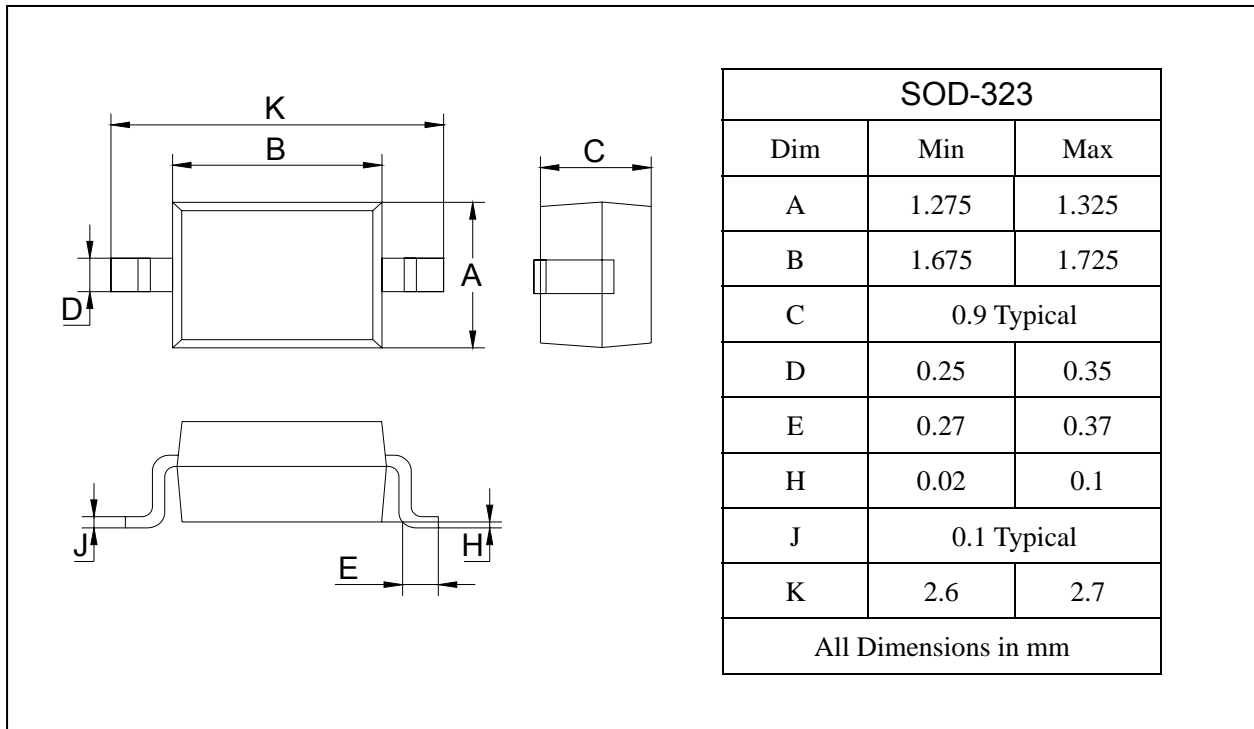

SOLDERING FOOTPRINT

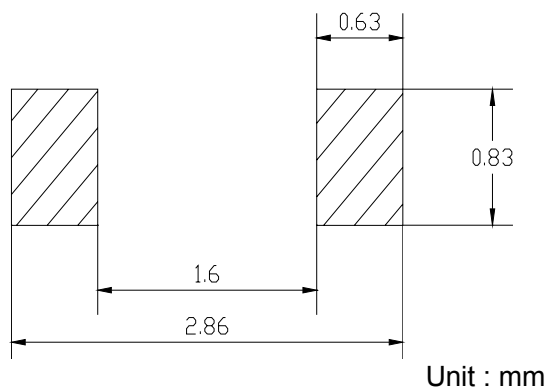

PACKAGE INFORMATION

Device	Package	Shipping
SD101AWS-SD101CWS	SOD-323	3000/Tape&Reel