

DC-AC INVERTER UNIT

PS-M05D12S3-NJ4L-012(S) (6,5 W DUAL OUTPUTS)

(PRELIMINARY INFORMATION)

DESCRIPTION :

This low profile DC to AC Inverter is developed for dual lamps.
Optimized for **Sharp: LQ064V3DG01**



APPLICABLE LCD:

- 6.4 to 12 inches double lamp type
- Lamp Current 5 mArms
- Lamp Start Up Voltage 900 Vrms (Vin : 12 Vdc)

FEATURES :

- Remote ON/OFF
- Ext. PWM-Dimming Function
- RoHS compliant (S)

TEMPERATURE & HUMIDITY :

- Operating Temperature Range 0°C ~ +60°C
- Storage Temperature Range -20°C ~ +85°C
- Humidity 95 %RH max

DIMENSIONS : L x W x H **105 x 22,5 x 10mm**

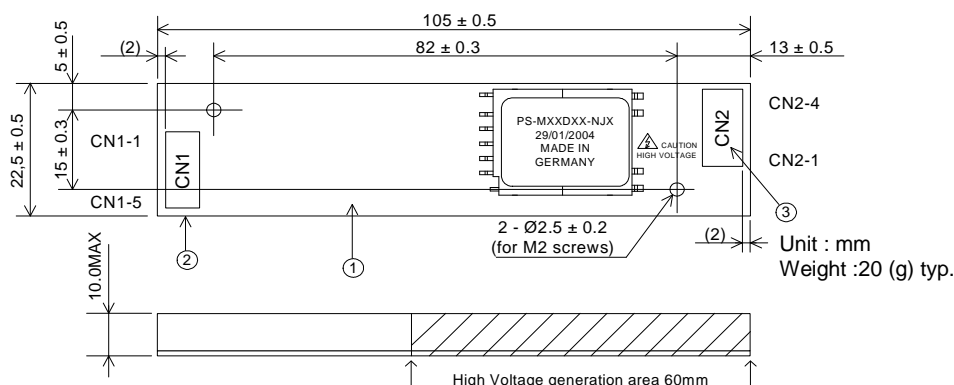

Components

No.	Part Description	Qty.	Material	Note
1	PCB	1	UL94V-0 (FR-4 or CEM-3)	t=1.6mm
2	Connector CN1	1	S5B-PH-SM3	JST or equal
3	Connector CN2	1	SM03(4.0)B-BHS	JST or equal

Input side CN1:

Pin No.	Symbols	Ratings
CN 1-1	Vin	12 Vdc
CN 1-2	GND	
CN 1-3	Ext. PWM	0 ~ 5 Vdc (L activ)
CN 1-4	N.C.	
CN 1-5	Vrmt	0 / 5 Vdc (H activ)

Output side CN2:

Pin No.	Symbols	Ratings
CN 2-1+2	VHIGH1	520 Vrms (5 mArms)
CN 2-3	VLOW	0 Vdc

Power Systems – The Power Solution

Web: www.Power-Systems.de
Email: Info@Power-Systems.de

Address: Hauptstr. 48 ; 74360 Ilfeld-Auenstein / Germany
Tel. : + 49 / 70 62 / 67 59 - 6
Fax: + 49 / 70 62 / 67 59 - 800

DC-AC INVERTER UNIT

PS-M05D12S3-NJ4L-012(S) (6,5 W DUAL OUTPUTS)

(PRELIMINARY INFORMATION)

ELECTRICAL CHARACTERISTICS :

Parameters	Symbols	Conditions			Specification			Unit	Note
		Vin (V)	Vrmt (V)	Tu (°C)	Min.	Typ.	Max.		
Output Current	Iout	12±0.12	5±0.25	0 ~ +60	4.5	5.0	5.5	mArms	Duty 100%
Output Current	Iout	12±1.2	5±0.25	0 ~ +60	4.0	5.0	6.0	mArms	
Input Current	Iin	12±1.2	5±0.25	0 ~ +60	-	0.7	1.2	Adc	
Frequency	F	12±1.2	5±0.25	0 ~ +60	45	55	65	kHz	
Open Circuit Voltage	Vopen	11,4	5±0.25	0 ~ +60	1.100	-	-	Vrms	

- Note 1 : Please keep minimum of 2mm clearance (all directions) between inverter high voltage area as marked on mechanical drawing and any conductors.
- Note 2: Remote ON/OFF (CN1-5) has priority and can not be used in combination with External PWM Dimming (CN1-3). When 'Ext.PWM' (CN1-3) is used 'Vrmt' (CN1-5) should not be connected.
- Note 3: The external PWM frequency should be in a range of 100 ~ 500 Hz. For other frequency please request. The optimum is normally at 250 Hz, and minimizes the interference disturbances of the vertical sync. frequency.

TEST CIRCUIT :

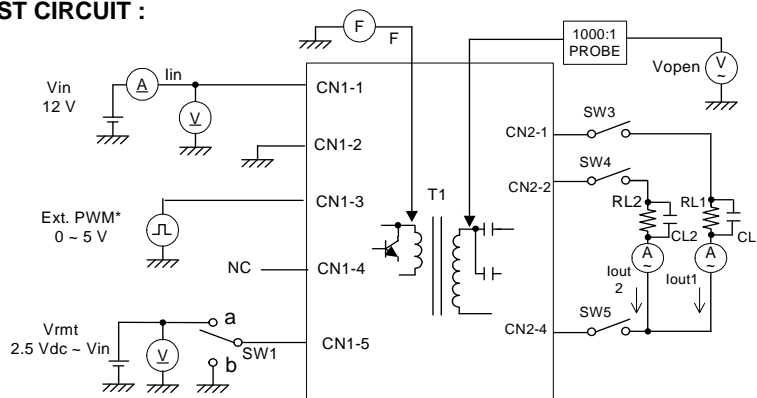

SW1	Operation of unit
a	Operation
b	Non operation

*) Only active when Vrmt is 0 Vdc or floating

EXTERNAL PWM-DIMMING (Remote ON / OFF Detailed Circuit Diagram):

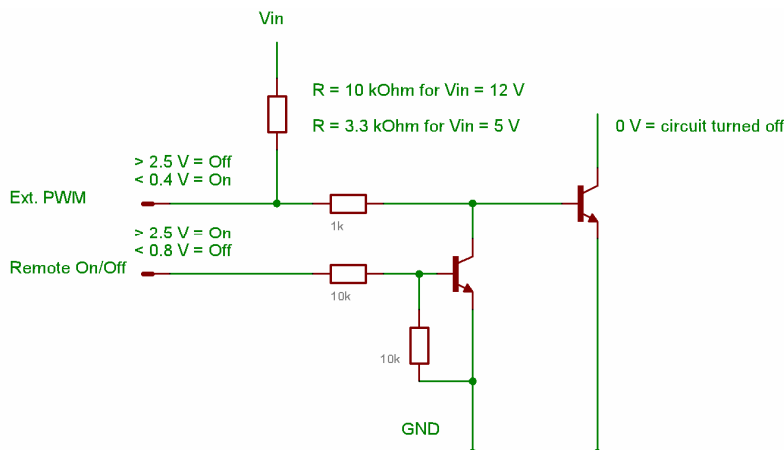

Power Systems – The Power Solution

Web: www.Power-Systems.de
 Email: Info@Power-Systems.de

Address: Hauptstr. 48 ; 74360 Ilsfeld-Auenstein / Germany
 Tel. : + 49 / 70 62 / 67 59 - 6
 Fax: + 49 / 70 62 / 67 59 - 800