

# Through Hole Gap Toroidal Inductors

## Through Hole Gap Toroidal Coils Make Your Design More Cost-Effective (TC19)

### ▶ Preview

Gapped toroidal coils usually require that the gap be filled with some type of insulating material to facilitate the winding process. Split core current coils can be assembled directly on a conductor while toroids must be passed over a disconnected end of the conductor.

Toroidal inductors are electronic components with the high performers among inductors, typically consisting of a circular ring-shaped magnetic core of iron powder, ferrite, or other material around which wire is coiled to make an inductor. Their windings cool better because of the proportionally larger surface area. Toroidal inductors with a round core cross section are better performers than toroidal inductors with a rectangular cross section.

Token utilizes the latest micro gap toroid technology enabling the most cost-effective designs in manufacturing through hole (TC19) products. Token's TC19 Toroidal Series manufactured by Low loss powdered iron cores offer the compact size and lower electromagnetic interference (EMI). Token toroidal can have higher Q factors and higher inductance than similarly constructed solenoid coils. This is due largely to the smaller number of turns required when the core provides a closed magnetic path. The magnetic flux in a toroid is largely confined to the core, preventing its energy from being absorbed by nearby objects, making toroidal cores essentially self-shielding. The TC19 series is suitable for a broad range of applications, such as high-frequency coils and transformers.

Full line products meet RoHS compliant. Token will also produce devices outside these specifications to meet specific customer requirements, please contact our sales for more information.

### Features :

- Micro gap toroid technology.
- Not easy magnetic saturation.

### Applications :

- VCD, DVD.

## Configurations & Dimensions

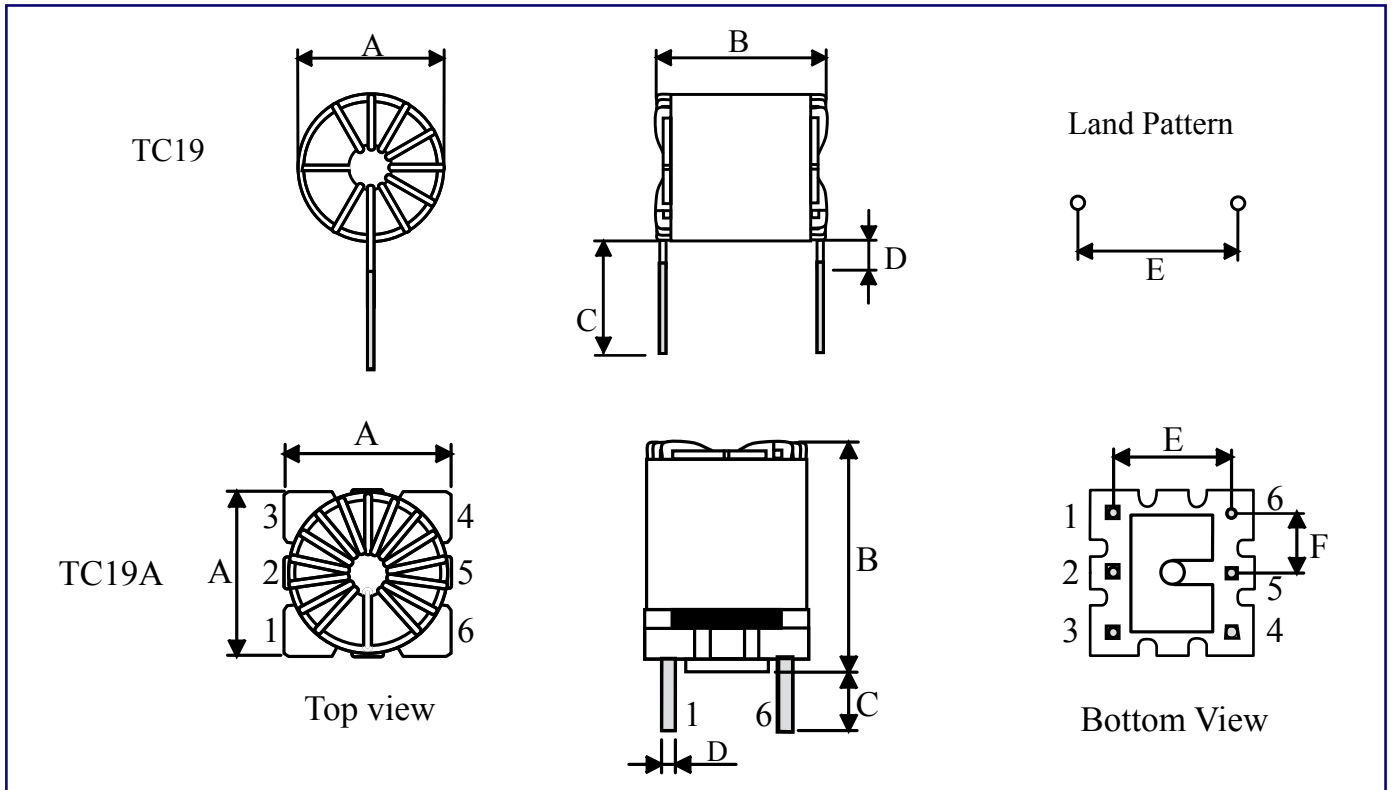

Type	A	B	C	D	E	F
TC19	10.0 (Ref.)	11.5 (Ref.)	15.0 ± 5.0	2.0 (max)	11.0	-
TC19A	11.0 (Ref.)	15.0 (Ref.)	3.5 ± 1.0	0.6 ± 0.05	7.0 ± 0.5	3.5 ± 0.5

**Note:** Design as Customer's Requested Specifications.

## Electrical Characteristics

Part Number	Inductance(μH)	Test Freq.(KHz)	DCR (Ω)(max)	IDC (A)(max)
TC19	19.5	100	0.093	3.00
TC19A	19.5	100	0.093	3.00

**Note:** Test Freq.: 100KHz / 0.1V.

Operating Temp.: -40°C ~ +85°C

Inductance drop = 10% typ. at IDC.

## How to Order

TC19

❶

0606

❷

❶ Power Inductor Through Hole Gap Toroidal Coils: TC19, TC19A

*Back to 1st Page - Power Inductor Gap Toroidal coils (TC19)*