



LTC5543

2.3GHz to 4GHz High Dynamic Range Downconverting Mixer

FEATURES

- Conversion Gain: 8.4dB at 2500MHz
- IIP3: 24.5dBm at 2500MHz
- Noise Figure: 10.2dB at 2500MHz
- High Input P1dB
- 3.3V Supply, 660mW Power Consumption
- Shutdown Pin
- 50Ω Single-Ended RF and LO Inputs
- LO Inputs 50Ω Matched when Shutdown
- High Isolation LO Switch
- 0dBm LO Drive Level
- High LO-RF and LO-IF Isolation
- Small Solution Size
- 20-Lead (5mm × 5mm) QFN package

APPLICATIONS

- Wireless Infrastructure Receivers (LTE, WiMAX, WCS)
- High Dynamic Range Downmixer Applications

LT, LT, LTC, LTM, Linear Technology and the Linear logo are registered trademarks of Linear Technology Corporation. All other trademarks are the property of their respective owners.

DESCRIPTION

The LTC[®]5543 is part of a family of high dynamic range passive downconverting mixers covering the 700MHz to 4GHz frequency range. **The LTC5543 is optimized for 2.3GHz to 4GHz RF applications. The LO frequency must fall within the 2.4GHz to 3.6GHz range for optimum performance.** A typical application is a LTE or WiMAX receiver with a 2.3GHz to 2.7GHz RF input and high-side LO.

The LTC5543 is designed for 3.3V operation, however; the IF amplifier can be powered by 5V for the highest P1dB. An integrated SPDT LO switch with fast switching accepts two active LO signals, while providing high isolation.

The LTC5543's high conversion gain and high dynamic range enable the use of lossy IF filters in high-selectivity receiver designs, while minimizing the total solution cost, board space and system-level variation.

High Dynamic Range Downconverting Mixer Family

PART#	RF RANGE	LO RANGE
LTC5540	600MHz – 1.3GHz	700MHz – 1.2GHz
LTC5541	1.3GHz – 2.3GHz	1.4GHz – 2.0GHz
LTC5542	1.6GHz – 2.7GHz	1.7GHz – 2.5GHz
LTC5543	2.3GHz – 4GHz	2.4GHz – 3.6GHz

TYPICAL APPLICATION

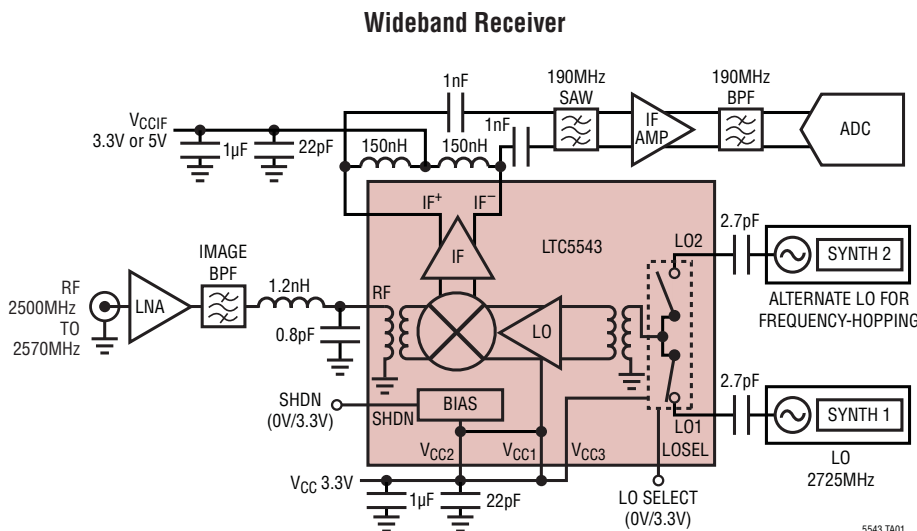

Wideband Conversion Gain, IIP3 and NF vs IF Output Frequency

