



**128Mbyte (32Mx32) 72-pin EDO Mode 4K Ref. SIMM Design 5V**  
**Part No. HMD32M32M16EG**

## GENERAL DESCRIPTION

The HMD32M32M16EG is a 16M x 32bit dynamic RAM high-density memory module. The module consists of sixteen CMOS 16M x 4bit DRAMs in 32-pin TSOPII packages mounted on a 72-pin, double-sided, FR-4-printed circuit board. A 0.1uF decoupling capacitor is mounted on the printed circuit board for each DRAM components. The module is a Single In-line Memory Module with edge connections and is intended for mounting in to 72-pin edge connector sockets. All module components may be powered from a single 5V DC power supply and all inputs and outputs are TTL-compatible.

## FEATURES

- w Part Identification  
HMD32M32M16EG—4K Cycles/64ms Ref. Gold
- w Access times : 50, 60ns
- w High-density 128MByte design
- w Single + 5V  $\pm 0.5V$  power supply
- w JEDEC standard pinout
- w EDO mode operation
- w TTL compatible inputs and outputs
- w FR4-PCB design

## OPTIONS

- w Timing
  - 50ns access
  - 60ns access
- w Packages
  - 72-pin SIMM

## MARKING

-5  
-6  
M

## PERFORMANCE RANGE

SPEED	tRAC	tCAC	tRC
-45	45ns	12ns	74ns
-5	50ns	13ns	84ns
-6	60ns	15ns	104ns

## PRESENCE DETECT PINS

Pin	50ns	60ns
PD1	NC	NC
PD2	Vss	Vss
PD3	Vss	NC
PD4	Vss	NC

## PIN ASSIGNMENT

PIN	SYMBOL	PIN	SYMBOL	PIN	SYMBOL
1	Vss	25	DQ22	49	DQ8
2	DQ0	26	DQ7	50	DQ24
3	DQ16	27	DQ23	51	DQ9
4	DQ1	28	A7	52	DQ25
5	DQ17	29	A11	53	DQ10
6	DQ2	30	Vcc	54	DQ26
7	DQ18	31	A8	55	DQ11
8	DQ3	32	A9	56	DQ27
9	DQ19	33	/RAS3	57	DQ12
10	Vcc	34	/RAS2	58	DQ28
11	NC	35	NC	59	Vcc
12	A0	36	NC	60	DQ29
13	A1	37	NC	61	DQ13
14	A2	38	NC	62	DQ30
15	A3	39	Vss	63	DQ14
16	A4	40	/CAS0	64	DQ31
17	A5	41	/CAS2	65	DQ15
18	A6	42	/CAS3	66	NC
19	A10	43	/CAS1	67	PD1
20	DQ4	44	/RAS0	68	PD2
21	DQ20	45	/RAS1	69	PD3
22	DQ5	46	NC	70	PD4
23	DQ21	47	/WE	71	NC
24	DQ6	48	NC	72	Vss

## 72PIN SIMM TOP VIEW

FUNCTIONAL BLOCK DIAGRAM

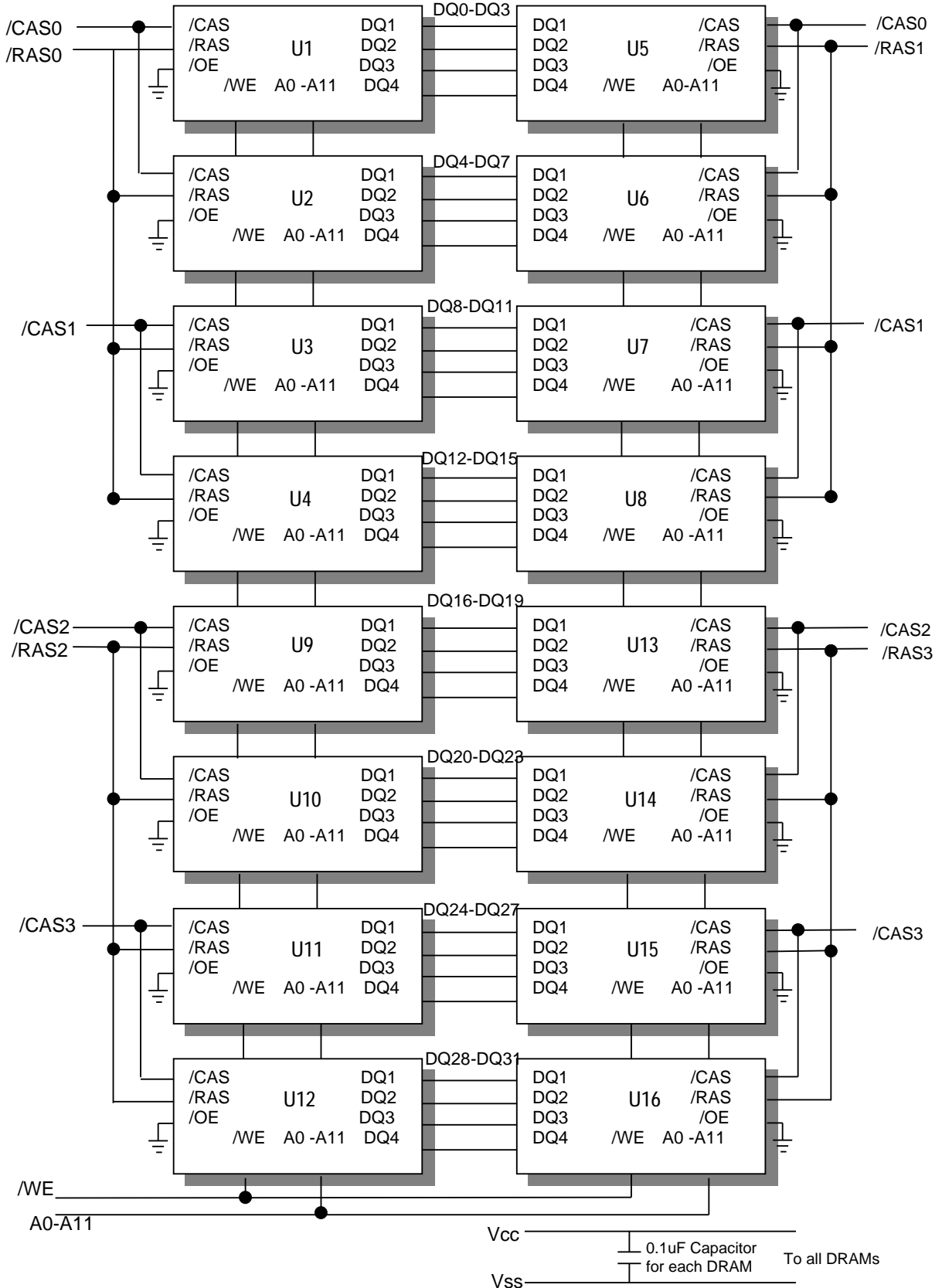

**ABSOLUTE MAXIMUM RATINGS**

PARAMETER	SYMBOL	RATING
Voltage on Any Pin Relative to V <sub>SS</sub>	V <sub>IN,OUT</sub>	-1V to 7.0V
Voltage on V <sub>CC</sub> Supply Relative to V <sub>SS</sub>	V <sub>CC</sub>	-1V to 7.0V
Power Dissipation	P <sub>D</sub>	16W
Storage Temperature	T <sub>STG</sub>	-55°C to 150°C
Short Circuit Output Current	I <sub>OS</sub>	50mA

Permanent device damage may occur if " Absolute Maximum Ratings" are exceeded. Functional operation should be restricted to the conditions as detailed in the operational sections of this data sheet. Exposure to absolute maximum rating conditions for extended periods may affect device reliability.

**RECOMMENDED DC OPERATING CONDITIONS**

( Voltage reference to V<sub>SS</sub>, T<sub>A</sub>=0 to 70 ° C )

PARAMETER	SYMBOL	MIN	TYP.	MAX	UNIT
Supply Voltage	V <sub>CC</sub>	4.5	5.0	5.5	V
Ground	V <sub>SS</sub>	0	0	0	V
Input High Voltage	V <sub>IH</sub>	2.4	-	V <sub>CC</sub> +1	V
Input Low Voltage	V <sub>IL</sub>	-1.0	-	0.8	V

**DC AND OPERATING CHARACTERISTICS**

SYMBOL	SPEED	MIN	MAX	UNITS
I <sub>CC1</sub>	-5	-	976	mA
	-6	-	896	mA
I <sub>CC2</sub>	Don't care	-	32	mA
I <sub>CC3</sub>	-5	-	976	mA
	-6	-	896	mA
I <sub>CC4</sub>	-5	-	896	mA
	-6	-	816	mA
I <sub>CC5</sub>	Don't care	-	16	mA
I <sub>CC6</sub>	-5	-	976	mA
	-6	-	896	mA
I <sub>I(L)</sub>		-10	10	μA
I <sub>O(L)</sub>		-5	5	μA
V <sub>OH</sub>		2.4	-	V
V <sub>OL</sub>		-	0.4	V

I<sub>CC1</sub> : Operating Current \* (/RAS , /CAS , Address cycling @t<sub>RC</sub>=min.)

I<sub>CC2</sub> : Standby Current ( /RAS=/CAS=V<sub>IH</sub> )

I<sub>CC3</sub> : /RAS Only Refresh Current \* ( /CAS=V<sub>IH</sub> , /RAS, Address cycling @t<sub>RC</sub>=min )

$I_{CC4}$ : Fast Page Mode Current \* (/RAS= $V_{IL}$ , /CAS, Address cycling @ $t_{PC}=\min$ )

$I_{CC5}$ : Standby Current (/RAS=/CAS= $V_{CC}-0.2V$ )

$I_{CC6}$ : /CAS-Before-/RAS Refresh Current \* (/RAS and /CAS cycling @ $t_{RC}=\min$ )

$I_{IL}$ : Input Leakage Current (Any input  $0V \leq V_{IN} \leq 6.5V$ , all other pins not under test =  $0V$ )

$I_{OL}$ : Output Leakage Current (Data out is disabled,  $0V \leq V_{OUT} \leq 5.5V$ )

$V_{OH}$ : Output High Voltage Level ( $I_{OH} = -5mA$ )

$V_{OL}$ : Output Low Voltage Level ( $I_{OL} = 4.2mA$ )

\* NOTE:  $I_{CC1}$ ,  $I_{CC3}$ ,  $I_{CC4}$  and  $I_{CC6}$  are dependent on output loading and cycle rates. Specified values are obtained with the output open.  $I_{CC}$  is specified as an average current. In  $I_{CC1}$  and  $I_{CC3}$ , address can be changed maximum once while /RAS= $V_{IL}$ . In  $I_{CC4}$ , address can be changed maximum once within one page mode cycle.

## CAPACITANCE ( $T_A=25^{\circ}C$ , $V_{CC} = 5V$ , $f = 1Mz$ )

DESCRIPTION	SYMBOL	MIN	MAX	UNITS
Input Capacitance (A0-A11)	$C_{IN1}$	-	90	pF
Input Capacitance (/W)	$C_{IN2}$	-	122	pF
Input Capacitance (/RAS0)	$C_{IN3}$	-	38	pF
Input Capacitance (/CAS0-/CAS3)	$C_{IN4}$	-	38	pF
Input/Output Capacitance (DQ0-31)	$C_{DQ1}$	-	17	pF

## AC CHARACTERISTICS ( $0^{\circ}C \leq T_A \leq 70^{\circ}C$ , $V_{CC} = 5V \pm 10\%$ , See notes 1,2.)

PARAMETER	SYMBOL	-5		-6		UNIT
		MIN	MAX	MIN	MAX	
Random read or write cycle time	$t_{RC}$	84		104		ns
Access time from /RAS	$t_{RAC}$		50		60	ns
Access time from /CAS	$t_{CAC}$		13		15	ns
Access time from column address	$t_{AA}$		25		30	ns
/CAS to output in Low-Z	$t_{CLZ}$	3		3		ns
Output buffer turn-off delay	$t_{OFF}$	3	13	3	15	ns
Transition time (rise and fall)	$t_T$	1	50	1	50	ns
/RAS precharge time	$t_{RP}$	30		40		ns
/RAS pulse width	$t_{RAS}$	50	10K	60	10K	ns
/RAS hold time	$t_{RSH}$	13		15		ns
/CAS hold time	$t_{CSH}$	38		45		ns
/CAS pulse width	$t_{CAS}$	8	10K	10	10K	ns
/RAS to /CAS delay time	$t_{RCD}$	20	37	20	45	ns
/RAS to column address delay time	$t_{RAD}$	15	25	15	30	ns
/CAS to /RAS precharge time	$t_{CRP}$	5		5		ns

Row address set-up time	$t_{ASR}$		0		0		ns
Row address hold time	$t_{RAH}$		10		10		ns
Column address set-up time	$t_{ASC}$		0		0		ns
Column Address to /RAS lead time	$t_{RAL}$		25		30		ns
Read command set-up time	$t_{RCS}$		0		0		ns
Read command hold referenced to /CAS	$t_{RCH}$		0		0		ns
Read command hold referenced to /RAS	$t_{RRH}$		0		0		ns
Write command hold time	$t_{WCH}$		10		10		ns
Write command hold referenced to /RAS	$t_{WCR}$		50		55		ns
Write command pulse width	$t_{WP}$		10		10		ns
Write command to /RAS lead time	$t_{RWL}$		13		15		ns
Write command to /CAS lead time	$t_{CWL}$		8		10		ns
Data-in set-up time	$t_{DS}$		0		0		ns
Data-in hold time	$t_{DH}$		8		10		ns
Refresh period	$t_{REF}$			64		64	ns
Write command set-up time	$t_{WCS}$		0		0		ns
/CAS setup time (C-B-R refresh)	$t_{CSR}$		5		5		ns
/CAS hold time (C-B-R refresh)	$t_{CHR}$		10		10		ns
/RAS precharge to /CAS hold time	$t_{RPC}$		5		5		ns

**NOTES**

1. An initial pause of 200 $\mu$ s is required after power-up followed by any 8 /RAS-only or /CAS-before-/RAS refresh cycles before proper device operation is achieved.
2.  $V_{IH(min)}$  and  $V_{IL(max)}$  are reference levels for measuring timing of input signals. Transition times are measured between  $V_{IH(min)}$  and  $V_{IL(max)}$  and are assumed to be 5ns for all inputs.
3. Measured with a load equivalent to 2TTL loads and 100pF
4. Operation within the  $t_{RCD(max)}$  limit insures that  $t_{RAC(max)}$  can be met.  $t_{RCD(max)}$  is specified as a reference point only. If  $t_{RCD}$  is greater than the specified  $t_{RCD(max)}$  limit, then access time is controlled exclusively by  $t_{CAC}$ .
5. Assumes that  $t_{RCD} \geq t_{RCD(max)}$
6.  $t_{AR}$ ,  $t_{WCR}$ ,  $t_{DHR}$  are referenced to  $t_{RAD(max)}$
7. This parameter defines the time at which the output achieves the open circuit condition and is not referenced to  $V_{OH}$  or  $V_{OL}$ .
8.  $t_{WCS}$ ,  $t_{RWD}$ ,  $t_{CWD}$  and  $t_{AWD}$  are non restrictive operating parameter.  
They are included in the data sheet as electrical characteristic only. If  $t_{WCS} \geq t_{WCS(min)}$  the cycle is an early write cycle and the data out pin will remain high impedance for the duration of the cycle.
9. Either  $t_{RCH}$  or  $t_{RRH}$  must be satisfied for a read cycle.
10. These parameters are referenced to the /CAS leading edge in early write cycles and to the /W leading edge in read-write cycles.
11. Operation within the  $t_{RAD(max)}$  limit insures that  $t_{RAC(max)}$  can be met.  $t_{RAD(max)}$  is specified as a reference point only. If  $t_{RAD}$  is greater than the specified  $t_{RAD(max)}$  limit, then access time is controlled by  $t_{AA}$ .

**AC CHARACTERISTICS** ( $0^{\circ}\text{C} \leq T_A \leq 70^{\circ}\text{C}$ ,  $V_{CC} = 5V \pm 10\%$ )

PARAMETER	SYMBOL	-5		-6		UNIT	NOTE
		MIN	MAX	MIN	MAX		
Hyper page mode cycle time	$t_{HPC}$	20		25		ns	11
/CAS precharge time (Hyper page cycle)	$t_{CP}$	8		10		ns	
/RAS pulse width (Hyper page cycle)	$t_{RASP}$	50	200K	60	200K	ns	
/RAS hold time from /CAS precharge	$t_{RHCP}$	30		35		ns	
/W to RAS precharge time (C-B-R refresh)	$t_{WRP}$	10		10		ns	
/W to RAS hold time (C-B-R refresh)	$t_{WRH}$	10		10		ns	
Output data hold time	$t_{DOH}$	5		5		ns	
Output buffer turn off delay from /RAS	$t_{REZ}$	3	13	3	15	ns	6,12
Output buffer turn off delay from W	$t_{WEZ}$	3	13	3	15	ns	6
/W to data delay	$t_{WED}$	15		15		ns	
/W puls width	$t_{WPE}$	5		5		ns	

**NOTES**

1. An initial pause of 200us is required after power-up followed by any 8 /RAS-only or /CAS-before-/RAS refresh cycles before proper device operation is achieved.
2. Input voltage levels are  $V_{IH}/V_{IL}$ .  $V_{IH}(\text{min})$  and  $V_{IL}(\text{max})$  are reference levels for measuring timing of input signals. Transition times are measured between  $V_{IH}(\text{min})$  and  $V_{IL}(\text{max})$  and are assumed to be 5ns for all inputs.
3. Measured with a load equivalent to 1 TTL loads and 100pF.
4. Operation within the  $t_{RCD}(\text{max})$  limit insures that  $t_{RAC}(\text{max})$  can be met.  $t_{RCD}(\text{max})$  is specified as a reference point only. If  $t_{RCD}$  is greater than the specified  $t_{RCD}(\text{max})$  limit, then access time is controlled exclusively by  $t_{CAC}$ .
5. Assumes that  $t_{RCD} \geq t_{RCD}(\text{max})$ .
6. This parameter defines the time at which the output achieves the open circuit and is not referenced for  $V_{OH}$  or  $V_{OL}$ .
7.  $t_{WCS}$  is non-restrictive operating parameter. It is included in the data sheet as electrical characteristics only. If  $t_{WCS} \geq t_{WCS}(\text{min})$ , the cycle is an early write cycle and the data out pin will remain high impedance for the duration of the cycle.
8. Either  $t_{RCH}$  or  $t_{RRH}$  must be satisfied for a read cycle.
9. These parameters are referenced to the /CAS leading edge in early write cycles.
10. Operation within the  $t_{RAD}(\text{max})$  limit insures that  $t_{RAC}(\text{max})$  can be met.  $t_{RAD}(\text{max})$  is specified as reference point only. If  $t_{RAD}$  is greater than the specified  $t_{RAD}(\text{max})$  limit access time is controlled by  $t_{AA}$ .
11.  $t_{ASC} \geq 6\text{ns}$ , Assume  $t = 2.0\text{ns}$ .
12. If /RAS goes high before /CAS high going, the open circuit condition of the output is achieved by /CAS high going. If /CAS goes high before /RAS high going, the open circuit condition of the output is achieved by /RAS going.

PACKAGING INFORMATION

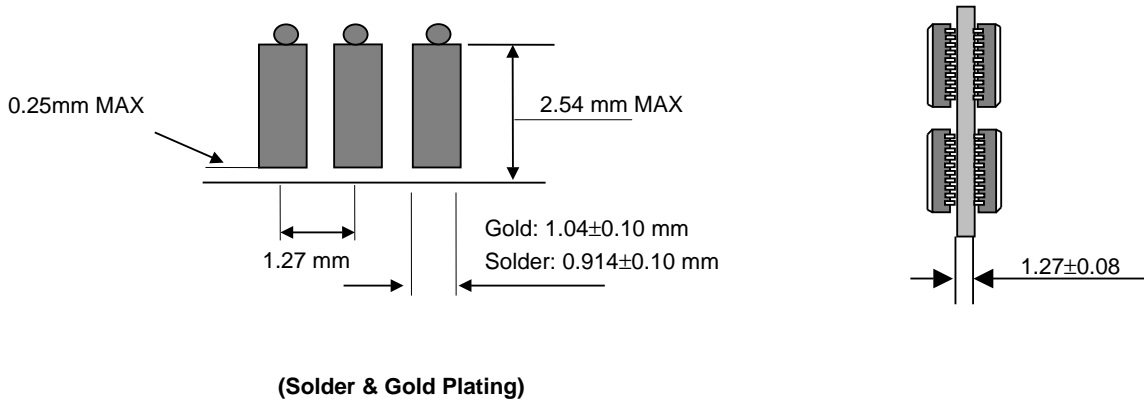
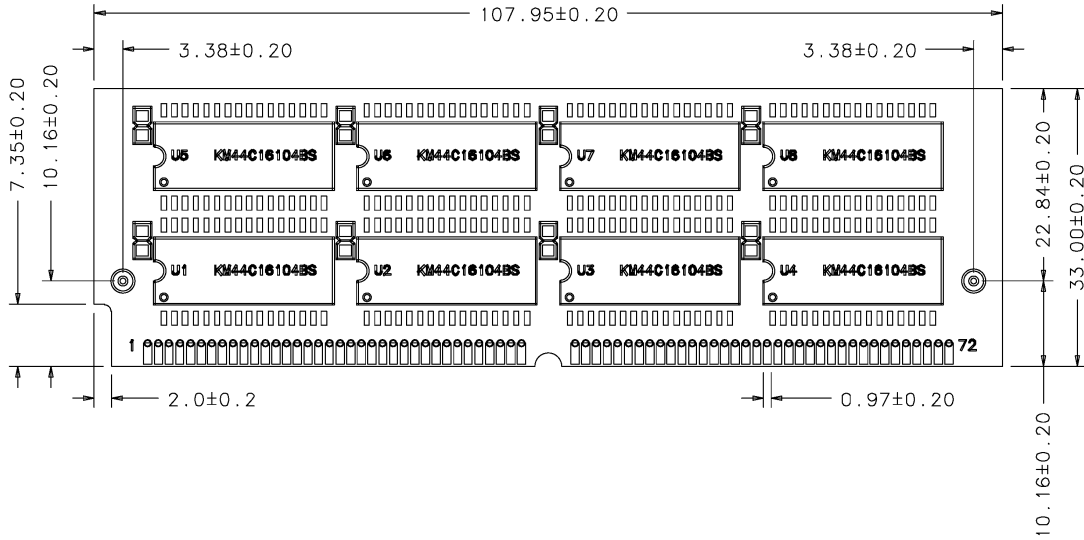

ORDERING INFORMATION

Part Number	Density	Org.	Package	Component Number	Vcc	MODE	SPEED
HMD32M32M16EG-5	128MByte	x 32	72 Pin-SIMM	16EA	5V	EDO	50ns
HMD32M32M16EG-6	128MByte	x 32	72 Pin-SIMM	16EA	5V	EDO	60ns