



# TAI-SAW TECHNOLOGY CO., LTD.

No. 3, Industrial 2nd Rd., Ping-Chen Industrial District,  
Taoyuan, 324, Taiwan, R.O.C.

TEL: 886-3-4690038 FAX: 886-3-4697532

E-mail: [tstsales@mail.taisaw.com](mailto:tstsales@mail.taisaw.com) Web: [www.taisaw.com](http://www.taisaw.com)

## Approval Sheet For Product Specification

Issued Date: 2/27/2007 (REV. NO: 1)

Product Name: SMD 3.2x2.5 40.0MHz VCTCXO

TST Parts No.: TX0225A

Customer Parts No.: \_\_\_\_\_

Company: _____
Division: _____
Approved by: _____
Date: _____

Checked by: CC Hsu

Approval by: Robert Chang

Date: 2/27/2007



# TAI-SAW TECHNOLOGY CO., LTD.

No. 3, Industrial 2nd Rd., Ping-Chen Industrial District,  
Taoyuan, 324, Taiwan, R.O.C.

TEL: 886-3-4690038 FAX: 886-3-4697532

E-mail: [tstsales@mail.taisaw.com](mailto:tstsales@mail.taisaw.com) Web: [www.taisaw.com](http://www.taisaw.com)

## SMD 3.2x2.5 40.0MHz VCTCXO

MODEL NO.: TX0225A

REV. NO.: 1

### Features:

- Ultra Miniature SMD Package
- Good Frequency Stability
- Good Phase Noise Response

RoHS Compliant  
Lead free  
Lead-free soldering

### Description and Applications:

Surface mount 3.2mmx2.5mm VCTCXO for use in wireless communications devices

### Electrical Specifications:

TX0225A	Specifications
Nominal Frequency, Fo	40.000000 MHz
Storage Temperature Range	-40°C to +85°C
Operating Temperature Range	-30°C to +85°C
Power Supply Voltage, Vdd	2.8 V
Output Voltage with Load 10pF//10KΩ, Vout	0.8 Vp-p min
Output Waveform	Clipped Sinewave
Power Supply Current, Icc	2.0 mA max
Control Voltage, Vcon	1.4 +/- 1.0 V
DC Terminal Input Impedance	100K ohms min
Frequency Tolerance (Vcon=1.4V) as received	+/- 1.0 ppm max @ 25°C +/- 3°C
Frequency Stability	
a. Vs. Temperature (-30~85°C)	+/- 2.0 ppm
b. Vs. Load varied 10pF//10KΩ+/-10%	+/- 0.2 ppm
c. Vs. Supply Voltage varied 2.8+/-0.2V	+/- 0.3ppm
Aging	+/- 1 ppm/ year
After reflow	+/- 1 ppm/ 2 times
Vcon Frequency Control Range (1.4+/-1.0 V)	+/-10 ppm min.
Start Up Time (90% of final RF level in Vp-p)	2.0 msec max.
Harmonics	-5.0 dBc max
SSB Phase Noise (@1KHz Carrier Offset)	-130 dBc/Hz max

# Mechanical Dimensions (mm):

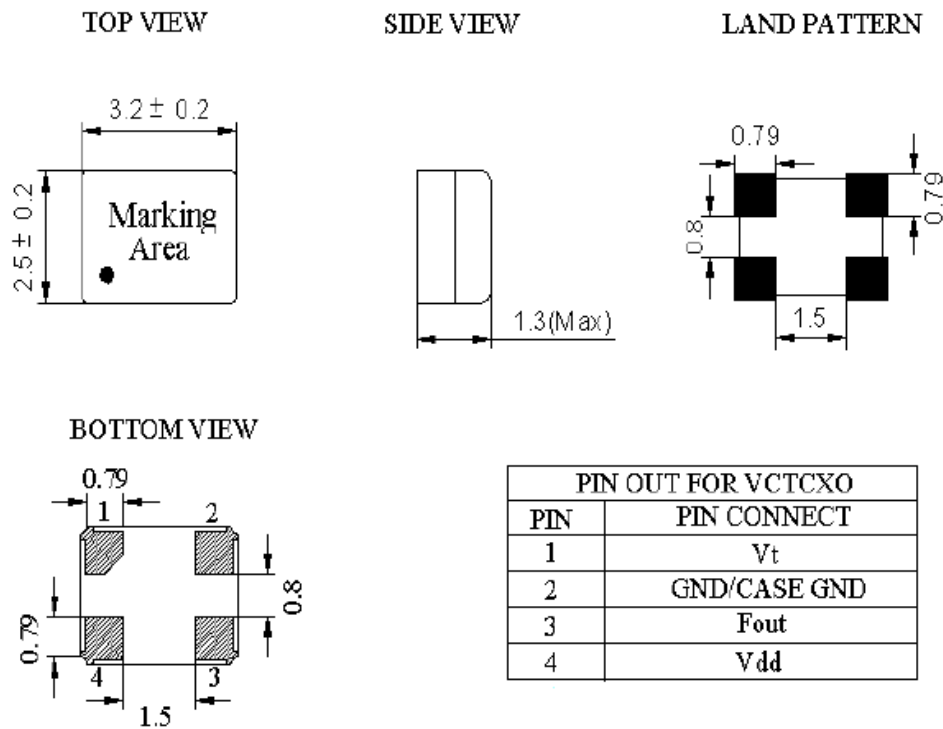

## Marking:

Line 1: Customer Frequency (40.00)

Line 2: TST Logo + Crystal Product Code + Date Code+ A

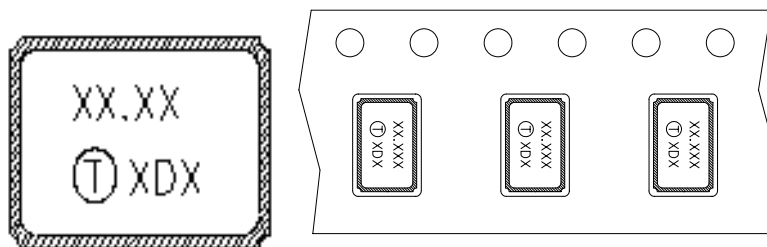

## Product Code Table

Year	2001 2005	2002 2006	2003 2007	2004 2008
Product Code	X	x	<u>X</u>	<u>x</u>

## Date Code Table

WK01	WK02	WK03	WK04	WK05	WK06	WK07	WK08	WK09	WK10	WK11	WK12	WK13
A	B	C	D	E	F	G	H	I	J	K	L	M
WK14	WK15	WK16	WK17	WK18	WK19	WK20	WK21	WK22	WK23	WK24	WK25	WK26
N	O	P	Q	R	S	T	U	V	W	X	Y	Z
WK27	WK28	WK29	WK30	WK31	WK32	WK33	WK34	WK35	WK36	WK37	WK38	WK39
a	b	c	d	e	f	g	h	i	j	k	l	m
WK40	WK41	WK42	WK43	WK44	WK45	WK46	WK47	WK48	WK49	WK50	WK51	WK52
n	o	p	q	r	s	t	u	v	w	x	y	z

## Recommended Circuit

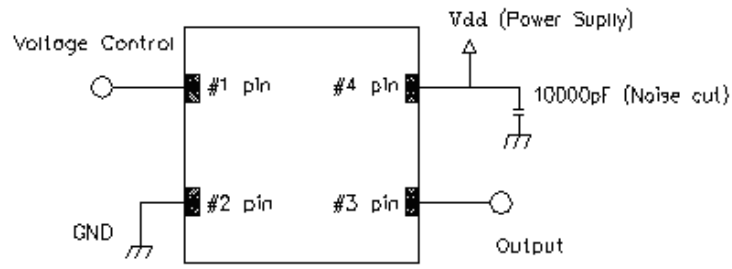

## Recommended Reflow Soldering Condition

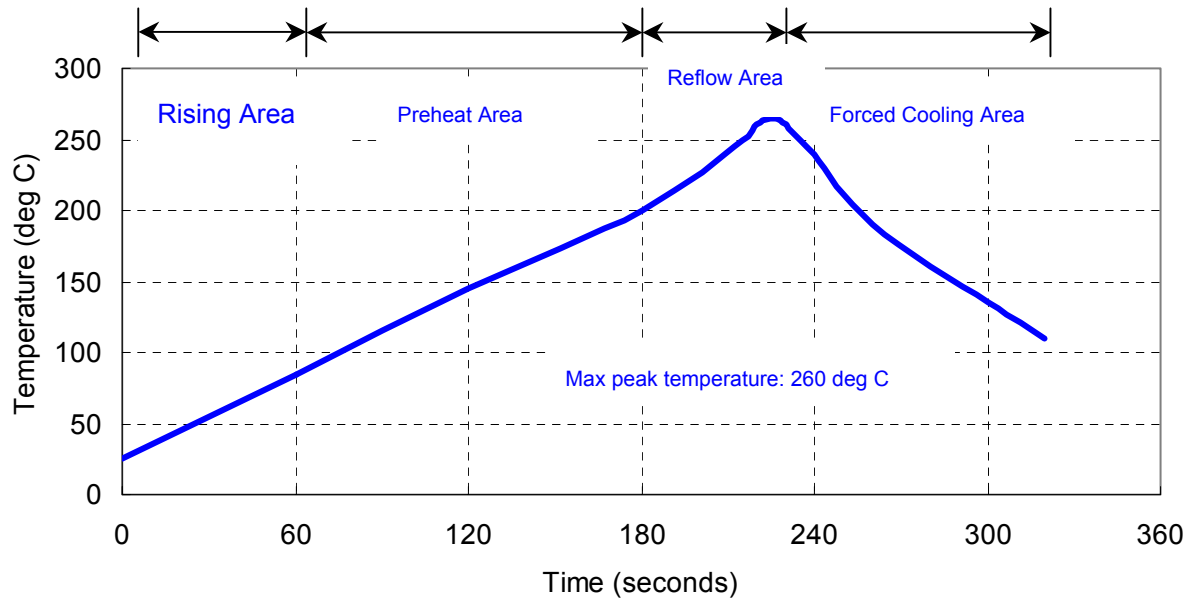

## Packing (mm):

### 1. Reel Dimension

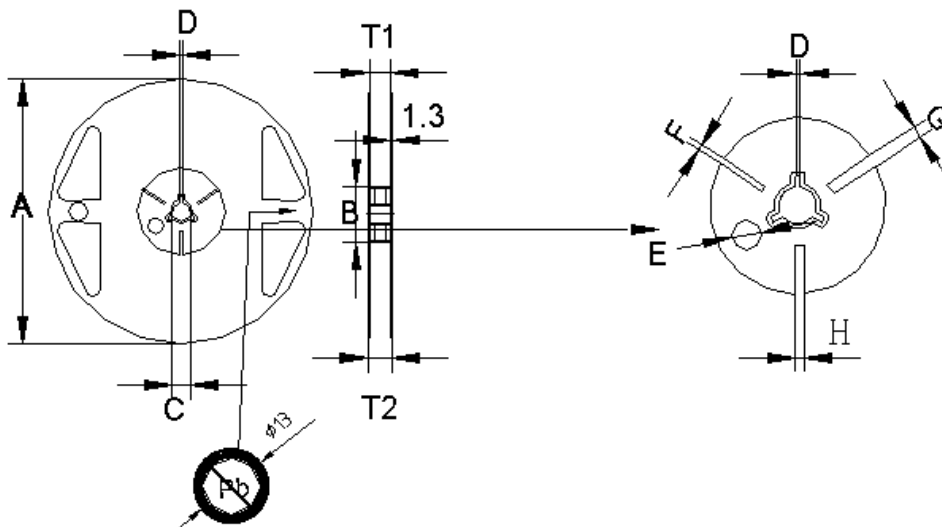

	A	B	C	D	E	F	H	G	T2	T1	T3
Dimensions	180	60	13.0	2.0	9.1	2.9	3.9	4.9	11.4	9.0	1.2
Tolerance	±1.0	±1.0	±0.2	±0.5	±0.5	±0.5	±0.5	±0.5	±1.0	±0.3	±0.1

## 2. Tape Dimension

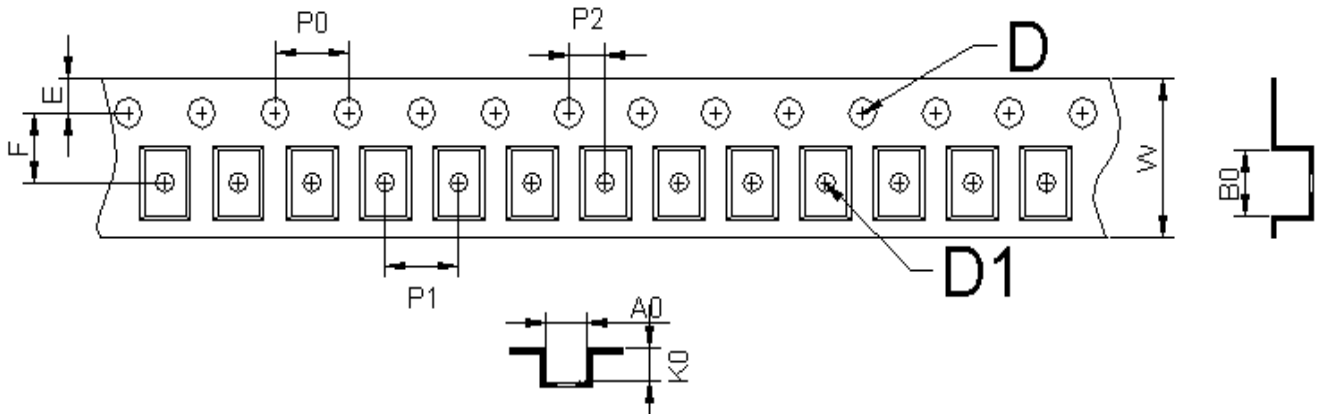

Unit: mm	A0	B0	W	F	E	P0	P1	P2	D1	D	K0	t
Dimension	2.80	3.71	8.00	3.5	1.75	4.00	4.00	2	1.50	1.0	1.75	0.25
Tolerance	±0.1	±0.1	+0.3/-0.1	±0.05	±0.1	±0.1	±0.1	±0.05	+0.1/-0.00	+0.25/-0.00	±0.1	±0.02

## Notes of the Usage:

1. Touch the solder iron at 260+/-5 deg C onto the leads for 10+/-2 sec max or touch the solder at 350+/-5 deg C onto the leads for 3+/-0.5 sec.
2. In the customer's reflow process, if it will remain some mechanical stress at the soldering terminals, also make some cracks on the soldering termination. Some cracks will cause open or short circuit and cause of thermal increasing or smoking. Don't make any excess mechanical stress to soldering points.
3. In case of giving a heavy shock to the products, it may make an open or short circuit and cause of thermal increasing and smoking. To avoid heavy shock impact applying to products is strictly required.

## Notes of the Storage:

1. To keep products under the condition at the room temperature (-5~35 deg C) with normal humidity (45~75%). Absorption of moisture and dewdrop may make inferiority of characteristics and a short circuit.
2. Oxidization of terminals shall make the solderability more inferior. Dusts and corrosive gas will make a cause of the open or short circuit. Keep it in the clean place where is not in dusty and no corrosive gas.
3. Use the anti-static material to the storage package.
4. Don't put any excess weight to the TCXO in the storage process.
5. Don't move the product from the cold place to the hot place in the short time, otherwise it may make some dew-drop, then a short circuit may happen in case.

6. Storage periods should be maximum 6 months under condition of above item 1 after delivery from TST factory.
7. Once open the bag, there is possibility of electrical characteristics deterioration due to absorption of moisture. So, please use parts within 7 days after opening the bag.
8. If you have to keep parts without using after opening the bag, please put the drying agent in the bag, fold the bag and keep it in the place where temperature and humidity are controlled (nitrogen atmosphere box etc.)