



# STG3P2M10N60B

1-Phase bridge rectifier + 3 phase inverter  
IGBT - SEMITOP<sup>®</sup>2 module

PRELIMINARY DATA

## General features

Type	V <sub>CE(S)</sub>	V <sub>CE(sat)(Max)</sub> @ I <sub>C</sub> =7A, T <sub>s</sub> =25°C	I <sub>C</sub> @80°C
STG3P2M10N60B	600V	< 2.5V	10A

- N-channel very fast PowerMESH<sup>™</sup> IGBT
- Lower on-voltage drop (V<sub>cesat</sub>)
- Lower C<sub>RES</sub> / C<sub>IES</sub> ratio (no cross-conduction susceptibility)
- Very soft ultra fast recovery antiparallel diode
- High frequency operation up to 70 KHz
- New generation products with tighter parameter distribution
- Compact design
- Semitop<sup>®</sup>2 is a trademark of semikron

## Description

Using the latest high voltage technology based on a patented strip layout, STMicroelectronics has designed an advanced family of IGBTs, the PowerMESH<sup>™</sup> IGBT, with outstanding performances.

## Applications

- High frequency motor controls
- Motor drivers

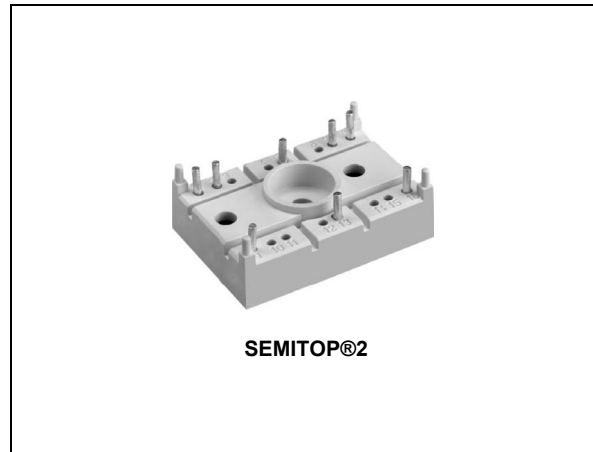

## Internal schematic diagram

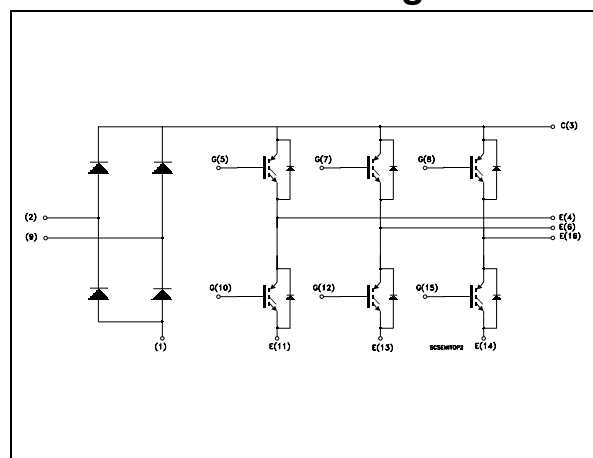

## Order codes

Sales type	Marking	Package	Packaging
STG3P2M10N60B	G3P2M10N60B	SEMITOP@2	SEMIBOX

## Contents

<b>1</b>	<b>Electrical ratings</b> .....	<b>3</b>
<b>2</b>	<b>Electrical characteristics</b> .....	<b>4</b>
	2.1 Typical characteristics (curves) .....	7
<b>3</b>	<b>Test circuit</b> .....	<b>8</b>
<b>4</b>	<b>Package mechanical data</b> .....	<b>9</b>
<b>5</b>	<b>Revision history</b> .....	<b>11</b>

# 1 Electrical ratings

**Table 1. Absolute maximum ratings**

Symbol	Parameter	Value	Unit
$V_{CES}$	Collector-emitter voltage ( $V_{GS} = 0$ )	600	V
$I_C^{(1)}$	Collector current (continuous) at $T_s = 25^\circ\text{C}$	19	A
$I_C^{(1)}$	Collector current (continuous) at $T_s = 80^\circ\text{C}$	10	A
$V_{GE}$	Gate-emitter Voltage	$\pm 20$	V
$I_{CM}^{(2)}$	$T_P < 1\text{ms}; T_s = 25^\circ\text{C}$	38	A
$I_{CM}$	$T_P < 1\text{ms}; T_s = 80^\circ\text{C}$	20	A
$I_F$	Diode RMS forward current at $T_s = 25^\circ\text{C}$	19	A
$P_{TOT}$	Total dissipation at $T_s = 25^\circ\text{C}$	56	W
$V_{ISO}$	Insulation withstand voltage A.C. ( $t = 1\text{min/sec}; T_s = 25^\circ\text{C}$ )	2500/3000	V
$T_{stg}$	Storage temperature	- 40 to 125	$^\circ\text{C}$
$T_j$	Operating junction temperature	- 40 to 150	$^\circ\text{C}$

1. Calculated value
2. Pulse width limited by max. junction temperature

**Table 2. Thermal resistance**

Symbol	Parameter	Value	Unit
$R_{th(j-s)}$	Thermal resistance junction-sink <sup>(1)</sup> Max.	2.2	K/W

1. Resistance value with conductive grease applied and maximum mounting torque equal to 2Nm

## 2 Electrical characteristics

( $T_S=25^\circ\text{C}$  unless otherwise specified)

**Table 3. Static**

Symbol	Parameter	Test conditions	Min.	Typ.	Max.	Unit
$V_{BR(CES)}$	Collector-emitter breakdown voltage	$I_C = 1\text{mA}$ , $V_{GE} = 0$	600			V
$I_{CES}$	Collector cut-off current ( $V_{GE} = 0$ )	$V_{CE} = \text{Max rating}$ , $T_S = 25^\circ\text{C}$ $V_{CE} = \text{Max rating}$ , $T_S = 125^\circ\text{C}$			10 1	$\mu\text{A}$ mA
$I_{GES}$	Gate-Emitter Leakage Current ( $V_{CE} = 0$ )	$V_{GE} = \pm 20\text{V}$ , $V_{CE} = 0$			$\pm 100$	nA
$V_{GE(th)}$	Gate Threshold Voltage	$V_{CE} = V_{GE}$ , $I_C = 250\mu\text{A}$	3.75		5.75	V
$V_{CE(sat)}$	Collector-emitter saturation voltage	$V_{GE} = 15\text{V}$ , $I_C = 7\text{A}$ $V_{GE} = 15\text{V}$ , $I_C = 7\text{A}$ , $T_C = 125^\circ\text{C}$		1.85 1.7	2.5	V V

**Table 4. Dynamic**

Symbol	Parameter	Test conditions	Min.	Typ.	Max.	Unit
$g_{fs}^{(1)}$	Forward transconductance	$V_{CE} = 15\text{V}$ , $I_C = 7\text{A}$		4.30		S
$C_{ies}$	Input capacitance	$V_{CE} = 25\text{V}$ , $f = 1\text{MHz}$ , $V_{GE} = 0$		720		pF
$C_{oes}$	Output capacitance			81		pF
$C_{res}$	Reverse transfer capacitance			17		pF
$Q_g$	Total gate charge	$V_{CE} = 390\text{V}$ , $I_C = 5\text{A}$ , $V_{GE} = 15\text{V}$ , (see Figure 8)		35	48	nC
$Q_{ge}$	Gate-emitter charge			7		nC
$Q_{gc}$	Gate-collector charge			16		nC

1. Pulsed: pulse duration=300 $\mu\text{s}$ , duty cycle 1.5%

**Table 5. Switching on/off**

Symbol	Parameter	Test conditions	Min.	Typ.	Max.	Unit
$t_{d(on)}$	Turn-on delay time	$V_{CC} = 300V, I_C = 7A$		18.5		ns
$t_r$	Current rise time	$R_G = 22\Omega, V_{GE} = \pm 15V$		8.5		ns
$(di/dt)_{on}$	Turn-on current slope	$T_S = 25^\circ C$ (see Figure 9)		1060		A/ $\mu s$
$t_{d(on)}$	Turn-on delay time	$V_{CC} = 300V, I_C = 7A$		18.5		ns
$t_r$	Current rise time	$R_G = 22\Omega, V_{GE} = \pm 15V$		7		ns
$(di/dt)_{on}$	Turn-on current slope	$T_S = 125^\circ C$ (see Figure 9)		1000		A/ $\mu s$
$t_r(V_{off})$	Off voltage rise time	$V_{CC} = 300V, I_C = 7A$		27		ns
$t_{d(off)}$	Turn-off delay time	$R_G = 22\Omega, V_{GE} = \pm 15V$		72		ns
$t_f$	Current fall time	$T_S = 25^\circ C$ (see Figure 9)		60		ns
$t_r(V_{off})$	Off voltage rise time	$V_{CC} = 300V, I_C = 7A$		56		ns
$t_{d(off)}$	Turn-off delay time	$R_G = 22\Omega, V_{GE} = \pm 15V$		116		ns
$t_f$	Current fall time	$T_S = 125^\circ C$ (see Figure 9)		105		ns

**Table 6. Switching energy (inductive load)**

Symbol	Parameter	Test conditions	Min.	Typ.	Max.	Unit
$E_{on}^{(1)}$	Turn-on switching losses	$V_{CC} = 300V, I_C = 7A$		95		$\mu J$
$E_{off}^{(2)}$	Turn-off switching losses	$R_G = 22\Omega, V_{GE} = \pm 15V$		115		$\mu J$
$E_{ts}$	Total switching losses	$T_S = 25^\circ C$ (see Figure 9)		210		$\mu J$
$E_{on}^{(1)}$	Turn-on switching losses	$V_{CC} = 300V, I_C = 7A$		140		$\mu J$
$E_{off}^{(2)}$	Turn-off switching losses	$R_G = 22\Omega, V_{GE} = \pm 15V$		215		$\mu J$
$E_{ts}$	Total switching losses	$T_S = 125^\circ C$ (see Figure 9)		355		$\mu J$

1.  $E_{on}$  is the turn-on losses when a typical diode is used in the test circuit in figure 2. If the IGBT is offered in a package with a co-pak diode, the co-pak diode is used as external diode. IGBTs & Diode are at the same temperature (25°C and 125°C)
2. Turn-off losses include also the tail of the collector current

**Table 7. Collector-emitter diode**

Symbol	Parameter	Test conditions	Min.	Typ.	Max.	Unit
$V_f$	Forward on-voltage	$I_f = 3.5A$ $I_f = 3.5A, T_S = 125^\circ C$		1.3 1.1	1.9	V V
$t_{rr}$ $t_a$ $Q_{rr}$ $I_{rrm}$ S	Reverse recovery time Reverse recovery charge Reverse recovery current Softness factor of the diode	$I_f = 7A, V_R = 40V,$ $T_S = 25^\circ C, di/dt = 100 A/\mu s$ (see Figure 6)		37 22 40 2.1 0.68		ns ns nC A
$t_{rr}$ $t_a$ $Q_{rr}$ $I_{rrm}$ S	Reverse recovery time Reverse recovery charge Reverse recovery current Softness factor of the diode	$I_f = 7A, V_R = 40V,$ $T_S = 125^\circ C, di/dt = 100A/\mu s$ (see Figure 6)		61 34 98 3.2 0.79		ns ns nC A

**Table 8. Bridge rectifier diode**

Symbol	Parameter	Test conditions	Min.	Typ.	Max.	Unit
$V_f$	Forward on-voltage	$I_f=20A, T_S=125^\circ C$		1.1		V
Rth(j-s)	Thermal resistance junction-sink <sup>(1)</sup>				2.15	K/W
Tj	Operating junction temperature		-40		150	°C

1. Resistance value with conductive grease applied and maximum mounting torque equal to 2Nm

## 2.1 Typical characteristics (curves)

Figure 1. Output characteristics at  $T_s=25^\circ\text{C}$

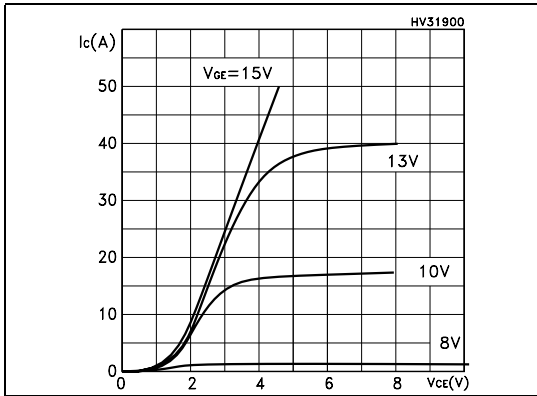

Figure 2. Output characteristics at  $T_s=125^\circ\text{C}$

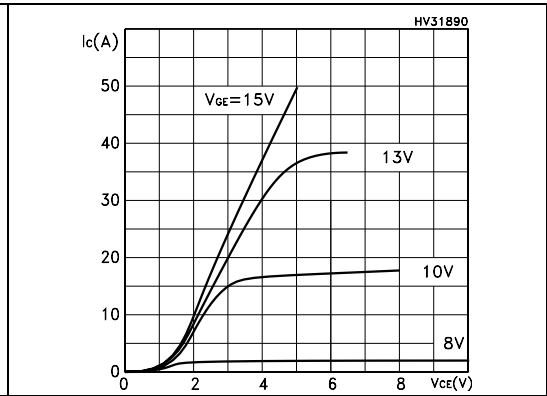

Figure 3. Capacitance variations

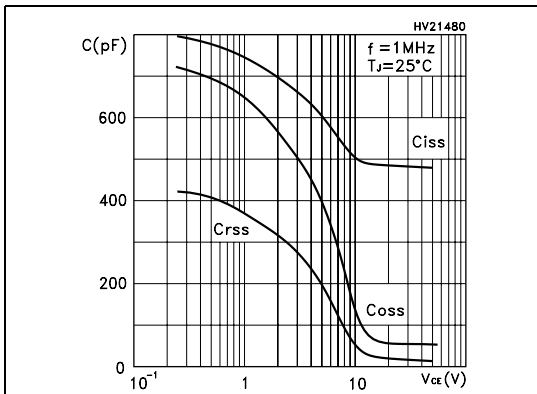

Figure 4. Gate charge vs gate-emitter voltage

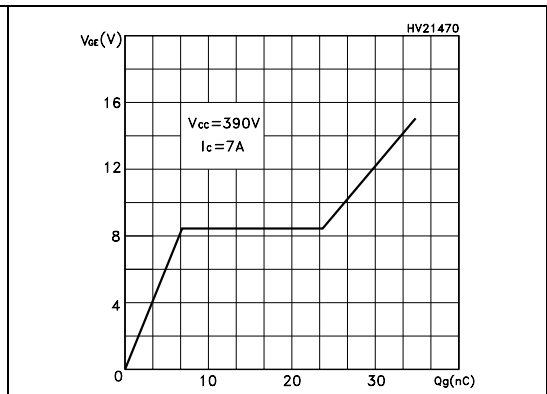

Figure 5. Total switching losses vs gate resistance

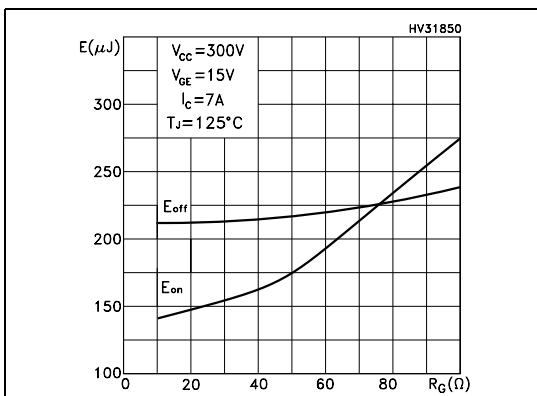
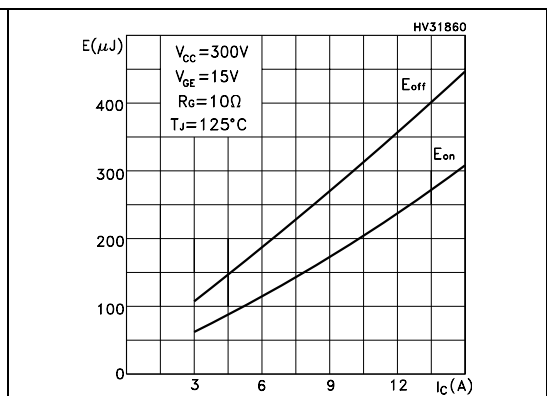

Figure 6. Total switching losses vs collector current



### 3 Test circuit

Figure 7. Test circuit for inductive load switching

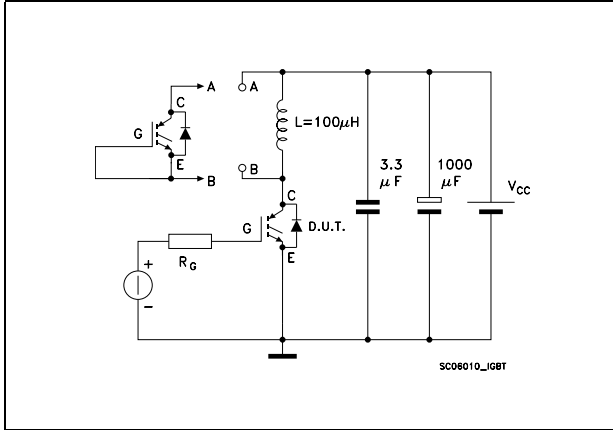

Figure 8. Gate charge test circuit

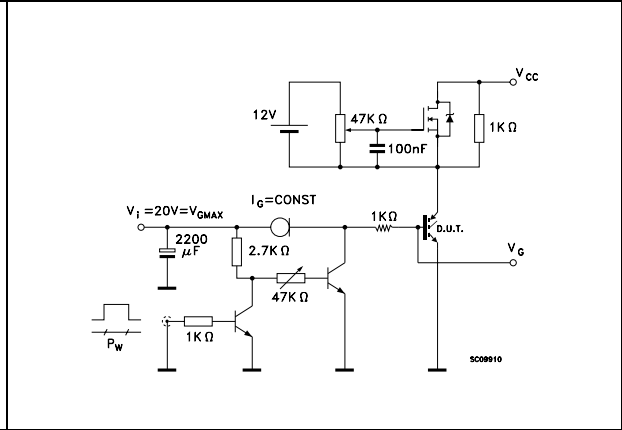

Figure 9. Switching waveform

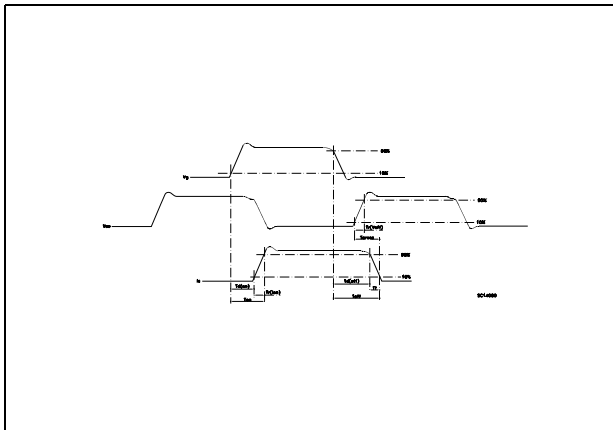
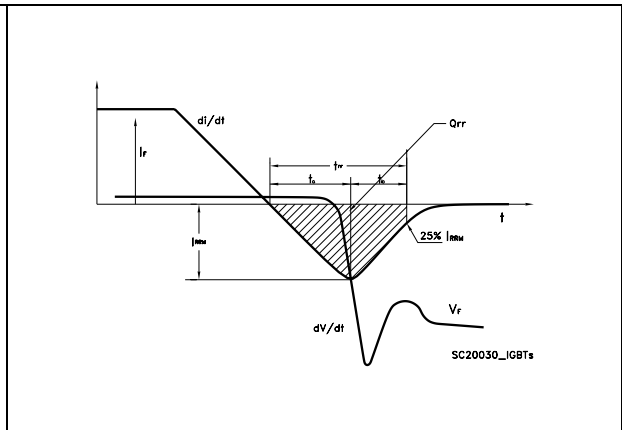

Figure 10. Diode recovery time waveform





## 4 Package mechanical data

In order to meet environmental requirements, ST offers these devices in ECOPACK® packages. These packages have a Lead-free second level interconnect . The category of second level interconnect is marked on the package and on the inner box label, in compliance with JEDEC Standard JESD97. The maximum ratings related to soldering conditions are also marked on the inner box label. ECOPACK is an ST trademark. ECOPACK specifications are available at: [www.st.com](http://www.st.com)

**SEMITOP®2 mechanical data**

Dim	mm		
	Min	Typ	Max
A	15.30	15.50	15.70
A1	15.23	15.43	15.63
A2		10.50	
A3		10	
øb		1.50	
øb1		1.60	
D	40.20	40.50	40.80
D2		38	
E	27.80	28	28.20
E1	19.80	20	20.20
E2		25.50	
e	2.90	3	3.10
e1		1.50	
e2	7.80	8	8.20
e3	3.90	4	4.10
f		2.50	
L		3.43	
L1		3.50	
L2	11.80	12	12.20
L3		5.20	
øP	4.30	4.40	4.50
øP1		12	
øP2		14.50	
R		1	

SEMITOP®2 is a trademark of SEMIKRON

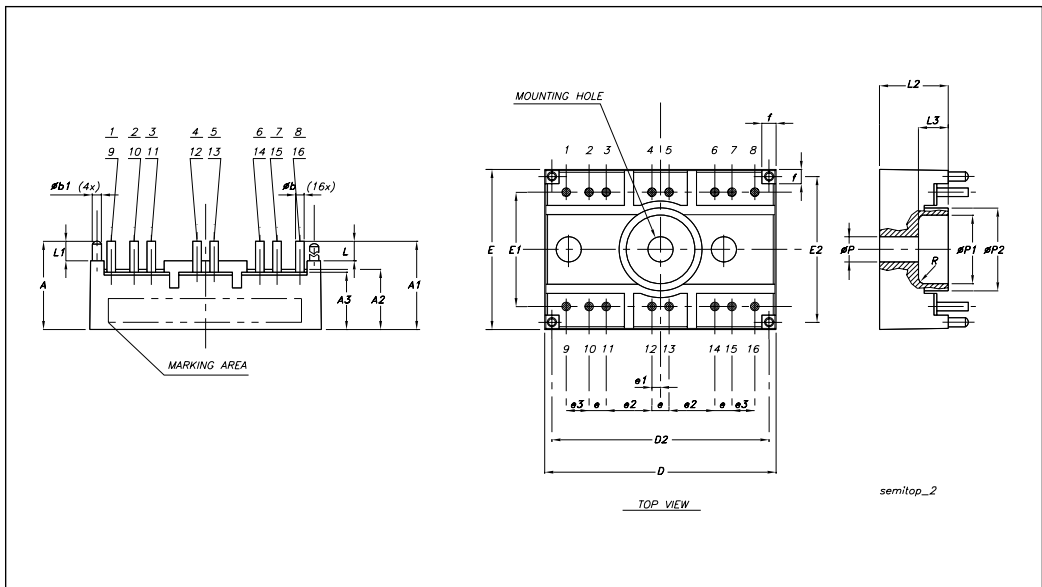

## 5 Revision history

Table 9. Revision history

Date	Revision	Changes
15-May-2005	1	Initial release.

**Please Read Carefully:**

Information in this document is provided solely in connection with ST products. STMicroelectronics NV and its subsidiaries ("ST") reserve the right to make changes, corrections, modifications or improvements, to this document, and the products and services described herein at any time, without notice.

All ST products are sold pursuant to ST's terms and conditions of sale.

Purchasers are solely responsible for the choice, selection and use of the ST products and services described herein, and ST assumes no liability whatsoever relating to the choice, selection or use of the ST products and services described herein.

No license, express or implied, by estoppel or otherwise, to any intellectual property rights is granted under this document. If any part of this document refers to any third party products or services it shall not be deemed a license grant by ST for the use of such third party products or services, or any intellectual property contained therein or considered as a warranty covering the use in any manner whatsoever of such third party products or services or any intellectual property contained therein.

**UNLESS OTHERWISE SET FORTH IN ST'S TERMS AND CONDITIONS OF SALE ST DISCLAIMS ANY EXPRESS OR IMPLIED WARRANTY WITH RESPECT TO THE USE AND/OR SALE OF ST PRODUCTS INCLUDING WITHOUT LIMITATION IMPLIED WARRANTIES OF MERCHANTABILITY, FITNESS FOR A PARTICULAR PURPOSE (AND THEIR EQUIVALENTS UNDER THE LAWS OF ANY JURISDICTION), OR INFRINGEMENT OF ANY PATENT, COPYRIGHT OR OTHER INTELLECTUAL PROPERTY RIGHT.**

**UNLESS EXPRESSLY APPROVED IN WRITING BY AN AUTHORIZE REPRESENTATIVE OF ST, ST PRODUCTS ARE NOT DESIGNED, AUTHORIZED OR WARRANTED FOR USE IN MILITARY, AIR CRAFT, SPACE, LIFE SAVING, OR LIFE SUSTAINING APPLICATIONS, NOR IN PRODUCTS OR SYSTEMS, WHERE FAILURE OR MALFUNCTION MAY RESULT IN PERSONAL INJURY, DEATH, OR SEVERE PROPERTY OR ENVIRONMENTAL DAMAGE.**

Resale of ST products with provisions different from the statements and/or technical features set forth in this document shall immediately void any warranty granted by ST for the ST product or service described herein and shall not create or extend in any manner whatsoever, any liability of ST.

ST and the ST logo are trademarks or registered trademarks of ST in various countries.

Information in this document supersedes and replaces all information previously supplied.

The ST logo is a registered trademark of STMicroelectronics. All other names are the property of their respective owners.

© 2006 STMicroelectronics - All rights reserved

STMicroelectronics group of companies

Australia - Belgium - Brazil - Canada - China - Czech Republic - Finland - France - Germany - Hong Kong - India - Israel - Italy - Japan - Malaysia - Malta - Morocco - Singapore - Spain - Sweden - Switzerland - United Kingdom - United States of America

[www.st.com](http://www.st.com)