

---

## LOW NOISE 300mA LDO REGULATOR

---

NO.EA-141-070727

### OUTLINE

The RP102x Series are CMOS-based voltage regulator ICs with high output voltage accuracy, extremely low supply current, low ON-resistance, and high ripple rejection. Each of these ICs consists of a voltage reference unit, an error amplifier, a resistor-net for voltage setting, a current limit circuit and a chip enable circuit.

These ICs perform with low dropout voltage and "chip enable" function. The line transient response and load transient response of the RP102x Series are excellent, thus these ICs are very suitable for the power supply for hand-held communication equipment.

The output voltage of these ICs is fixed with high accuracy. Since the packages for these ICs are SOT-23-5, PLP1820-6, and WLCSP-4-P2, therefore high density mounting of the ICs on boards is possible.

### FEATURES

- Supply Current ..... Typ. 50 $\mu$ A
- Standby Mode ..... Typ. 0.1 $\mu$ A
- Dropout Voltage ..... Typ. 0.12V ( $I_{OUT}=300\text{mA}$ ,  $V_{OUT}=2.8\text{V}$ )
- Ripple Rejection ..... Typ. 80dB ( $f=1\text{kHz}$ )
- Temperature-Drift Coefficient of Output Voltage ... Typ.  $\pm 20\text{ppm}/^\circ\text{C}$
- Line Regulation ..... Typ. 0.02%/V
- Output Voltage Accuracy .....  $\pm 0.8\%$
- Packages ..... WLCSP-4-P2, PLP1820-6, SOT-23-5
- Input Voltage Range ..... 1.7V to 5.25V
- Output Voltage ..... 1.2V, 1.25V, 1.3V, 1.5V, 1.8V, 1.85V, 2.5V, 2.6V, 2.7V, 2.8V, 2.85V, 2.9V, 3.0V, 3.3V
- Built-in Fold Back Protection Circuit ..... Typ. 50mA (Current at short mode)
- Ceramic capacitors are recommended to be used with this IC .....  $C_{IN}=C_{OUT}=1\mu\text{F}$  or more

### APPLICATIONS

- Power source for portable communication equipment.
- Power source for electrical appliances such as cameras, VCRs and camcorders.
- Power source for battery-powered equipment.

## BLOCK DIAGRAMS

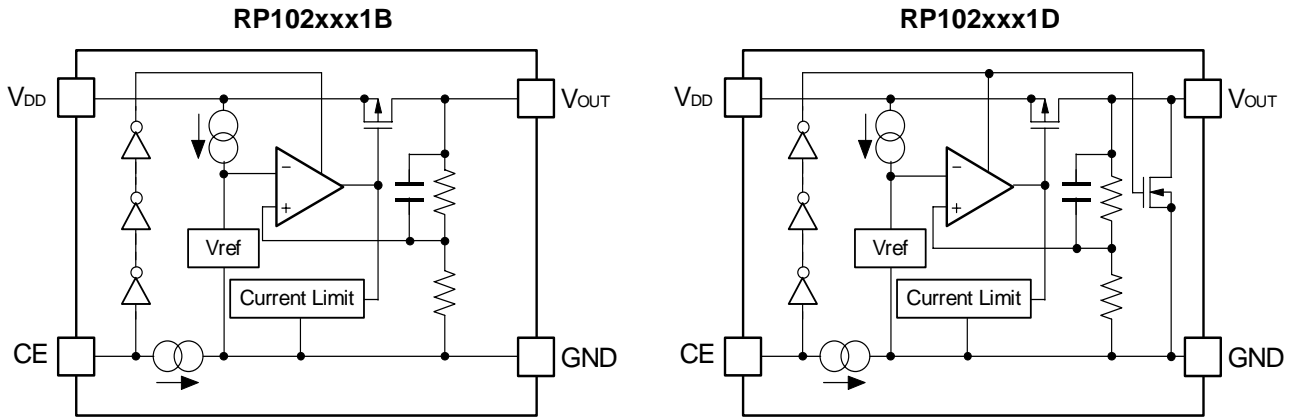

## SELECTION GUIDE

The output voltage, auto discharge function\*, and the taping type for the ICs can be selected at the user's request.

The selection can be made with designating the part number as shown below;

RP102xxx1x-xx-x ←Part Number  
 ↑ ↑ ↑ ↑ ↑  
 a b c d e

Code	Contents
a	Designation of Package Type: K: PLP1820-6 N: SOT-23-5 Z: WL-CSP4-P2
b	Setting Output Voltage (V <sub>OUT</sub> ): 1.2V, 1.25V, 1.3V, 1.5V, 1.8V, 1.85V, 2.5V, 2.6V, 2.7V, 2.8V, 2.85V, 2.9V, 3.0V, 3.3V Exceptions: 1.25V=RP102x121x5-xx-x, 1.85V=RP102x181x5-xx-x, 2.85V=RP102x281x5-xx-x.
c	Designation of Mask Option B: active high, without auto discharge function* at OFF state. D: active high, with auto discharge function* at OFF state.
d	Designation of Taping Type: Ex: TR (refer to Taping Specifications; TR type is the standard direction.)
e	Designation of composition of pin plating: -F: Lead free plating (SOT-23-5,WLCSP-4-P2) None: Au plating (PLP1820-6)

\*) When the mode is into standby with CE signal, auto discharge transistor turns on, and it makes the turn-off speed faster than normal type.

## PIN CONFIGURATIONS

### • WLCSP-4-P2

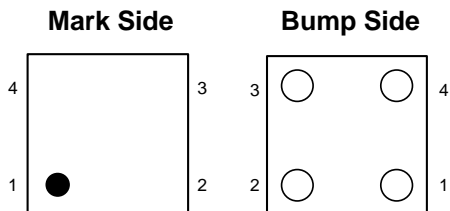

### • PLP1820-6

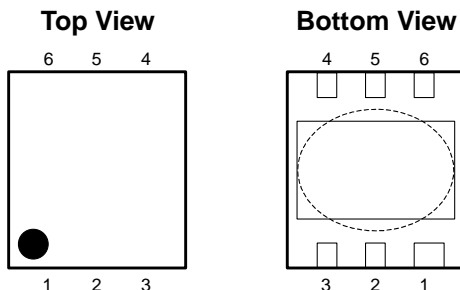

### • SOT-23-5

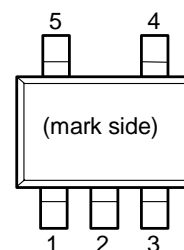

## PIN DESCRIPTION

### • WLCSP-4-P2

Pin No.	Symbol	Description
1	V <sub>DD</sub>	Input Pin
2	CE	Chip Enable Pin
3	GND	Ground Pin
4	V <sub>OUT</sub>	Output Pin

### • PLP1820-6\*

Pin No.	Symbol	Description
1	V <sub>OUT</sub>	Output Pin
2	V <sub>OUT</sub>	Output Pin
3	GND	Ground Pin
4	CE	Chip Enable Pin
5	V <sub>DD</sub>	Input Pin
6	V <sub>DD</sub>	Input Pin

\* Tab in the  parts have GND level.  
(They are connected to the back side of this IC.)  
Do not connect to other wires or land patterns.

### • SOT-23-5

Pin No.	Symbol	Description
1	V <sub>DD</sub>	Input Pin
2	GND	Ground Pin
3	CE	Chip Enable Pin
4	NC	No Connection
5	V <sub>OUT</sub>	Output Pin

## ABSOLUTE MAXIMUM RATINGS

Symbol	Item	Rating	Unit
$V_{IN}$	Input Voltage	6.0	V
$V_{CE}$	Input Voltage (CE Pin)	6.0	V
$V_{OUT}$	Output Voltage	-0.3 to $V_{IN}+0.3$	V
$I_{OUT}$	Output Current	300	mA
$P_D$	Power Dissipation (WLCSP-4-P2) *	530	mW
	Power Dissipation (PLP1820-6) *	420	
	Power Dissipation (SOT-23-5) *	880	
$T_{opt}$	Operating Temperature Range	-40 to 85	°C
$T_{stg}$	Storage Temperature Range	-55 to 125	°C

\*) For Power Dissipation, please refer to PACKAGE INFORMATION to be described.

## ELECTRICAL CHARACTERISTICS

### • RP102xxx1B/D

$V_{IN} = \text{Set } V_{OUT} + 1V$  for  $V_{OUT}$  options greater than 1.5V.  $V_{IN} = 2.5V$  for  $V_{OUT} \leq 1.5V$ .

$I_{OUT} = 1mA$ ,  $C_{IN} = C_{OUT} = 1\mu F$ , unless otherwise noted.

$T_{opt} = 25^{\circ}C$

Symbol	Item	Conditions	Min.	Typ.	Max.	Unit	
$V_{OUT}$	Output Voltage	$V_{IN} = \text{Set } V_{OUT} + 1V$	$V_{OUT} > 2.0V$	$\times 0.992$		$\times 1.008$	V
			$V_{OUT} \leq 2.0V$	-16		+16	mV
$I_{OUT}$	Output Current		300			mA	
$\frac{\Delta V_{OUT}}{\Delta I_{OUT}}$	Load Regulation	$1mA \leq I_{OUT} \leq 150mA$		10	20	mV	
		$1mA \leq I_{OUT} \leq 300mA$		20	40		
$V_{DIF}$	Dropout Voltage	Refer to the Electrical Characteristics by Output Voltage					
$I_{SS}$	Supply Current	$I_{OUT} = 0mA$		50	70	$\mu A$	
Istandby	Supply Current (Standby)	$V_{CE} = 0V$		0.1	2.0	$\mu A$	
$\frac{\Delta V_{OUT}}{\Delta V_{IN}}$	Line Regulation	Set $V_{OUT} + 0.5V \leq V_{IN} \leq 5V$		0.02	0.10	%/V	
RR	Ripple Rejection	$f = 1kHz$ , Ripple 0.2Vp-p $V_{IN} = \text{Set } V_{OUT} + 1V$ , $I_{OUT} = 30mA$ (In case that $V_{OUT} \leq 2V$ , $V_{IN} = 3V$ )		80		dB	
$V_{IN}$	Input Voltage*		1.7		5.25	V	
$\frac{\Delta V_{OUT}}{\Delta T_{opt}}$	Output Voltage Temperature Coefficient	$-40^{\circ}C \leq T_{opt} \leq 85^{\circ}C$		$\pm 20$		ppm/ $^{\circ}C$	
$I_{lim}$	Short Current Limit	$V_{OUT} = 0V$		50		mA	
$I_{PD}$	CE Pull-down Current		0.05	0.3	0.6	$\mu A$	
$V_{CEH}$	CE Input Voltage "H"		1.5			V	
$V_{CEL}$	CE Input Voltage "L"				0.3	V	
en	Output Noise	$BW = 10Hz$ to $100kHz$ $I_{OUT} = 30mA$		30		$\mu V_{rms}$	
$R_{LOW}$	Low Output Nch Tr. ON Resistance (of D version)	$V_{IN} = 4V$ $V_{CE} = 0V$		30		$\Omega$	

\*) When Input Voltage is 5.5V, the total operational time must be within 500hrs.

### • Electrical Characteristics by Output Voltage

$T_{opt} = 25^{\circ}C$

Output Voltage $V_{OUT}$ (V)	Dropout Voltage $V_{DIF}$ (V)					
	Condition	Typ.	Max.	Condition	Typ.	Max.
$1.2V \leq V_{OUT} < 1.5V$	$I_{OUT} = 150mA$	0.145	-	$I_{OUT} = 300mA$	0.290	0.500
$1.5V \leq V_{OUT} < 1.7V$		0.110	0.160		0.220	0.320
$1.7V \leq V_{OUT} < 2.0V$		0.100	0.140		0.200	0.280
$2.0V \leq V_{OUT} < 2.5V$		0.085	0.120		0.170	0.240
$2.5V \leq V_{OUT} < 2.8V$		0.070	0.100		0.140	0.200
$2.8V \leq V_{OUT} \leq 3.3V$		0.060	0.095		0.120	0.190

## TYPICAL APPLICATION

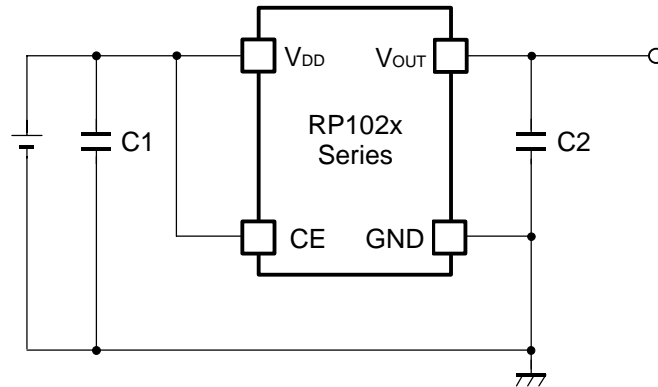

## TECHNICAL NOTES

When using these ICs, consider the following points:

### Phase Compensation

In these ICs, phase compensation is made for securing stable operation even if the load current is varied. For this purpose, use a capacitor C2 with good frequency characteristics and ESR (Equivalent Series Resistance). (Note: If additional ceramic capacitors are connected with parallel to the output pin with an output capacitor for phase compensation, the operation might be unstable. Because of this, test these ICs with as same external components as ones to be used on the PCB.)

### PCB Layout

Make  $V_{DD}$  and GND lines sufficient. If their impedance is high, noise pickup or unstable operation may result. Connect a capacitor C1 with a capacitance value as much as  $1.0\mu\text{F}$  or more between  $V_{DD}$  and GND pin, and as close as possible to the pins.

Set external components, especially the output capacitor C2, as close as possible to the ICs, and make wiring as short as possible.

**TEST CIRCUITS**

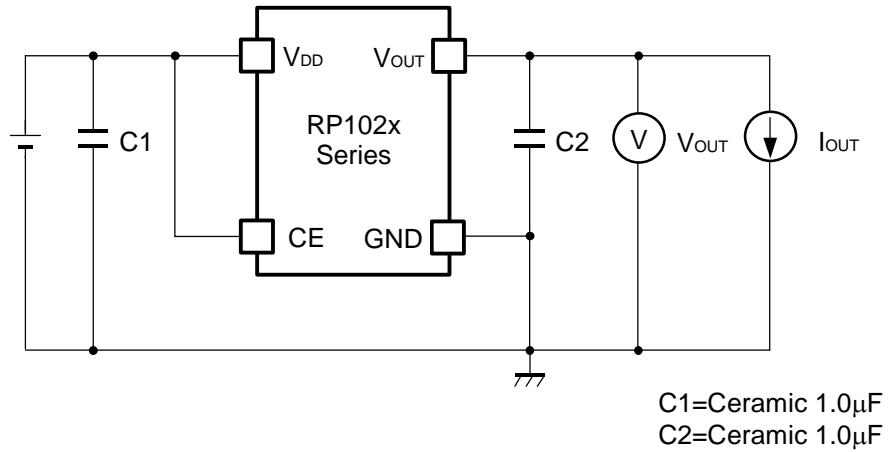

**Basic Test Circuit**

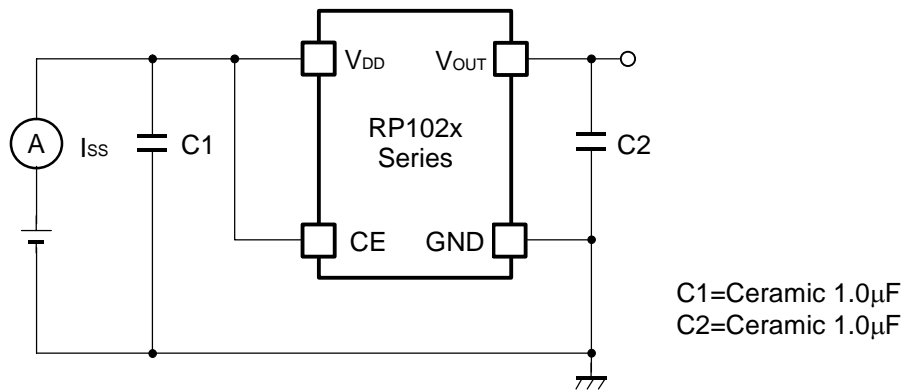

**Test Circuit for Supply Current**

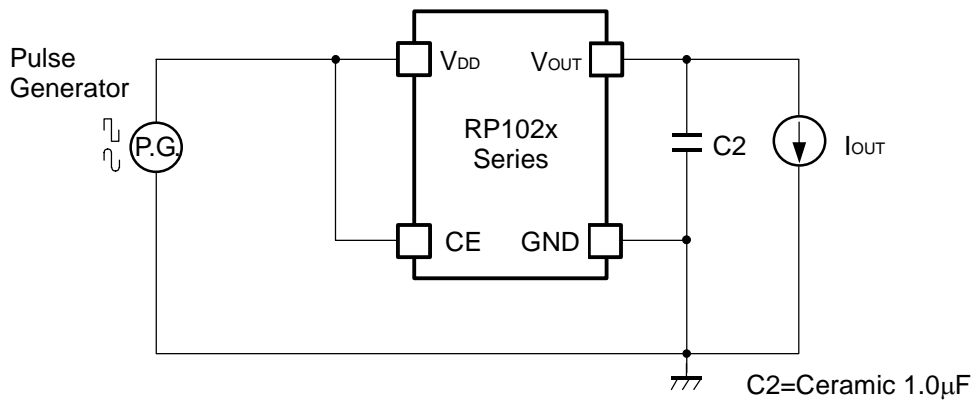

**Test Circuit for Ripple Rejection**

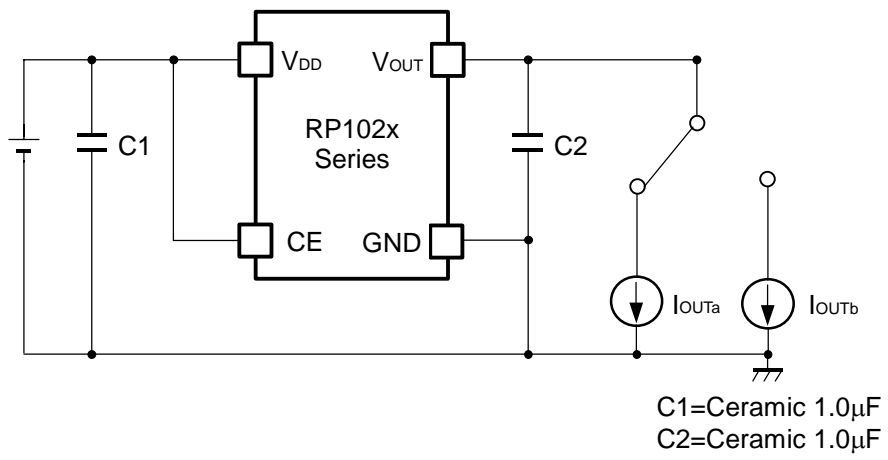

**Test Circuit for Load Transient Response**



## TYPICAL CHARACTERISTIC

### 1) Output Voltage vs. Output Current ( $C_{IN}=1.0\mu F$ , $C_{OUT}=1.0\mu F$ , $T_{opt}=25^{\circ}C$ )

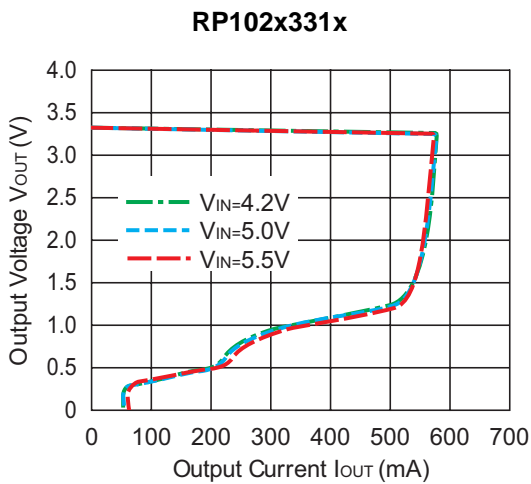
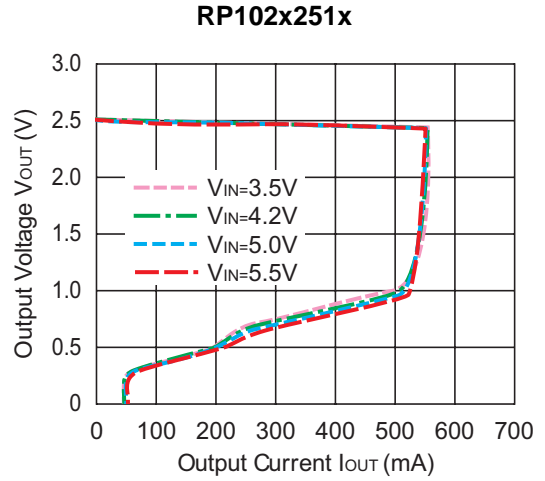
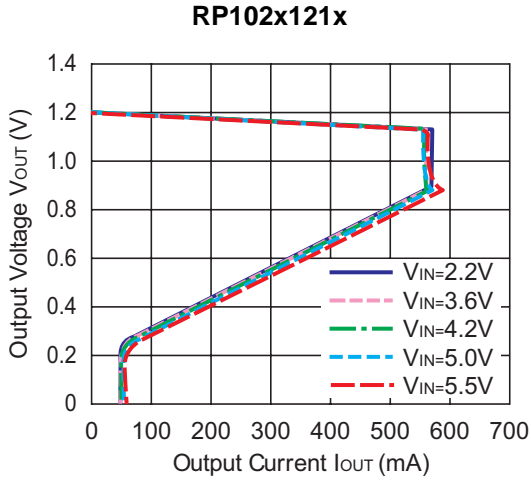

### 2) Output Voltage vs. Input Voltage ( $C_{IN}=1.0\mu F$ , $C_{OUT}=1.0\mu F$ , $T_{opt}=25^{\circ}C$ )

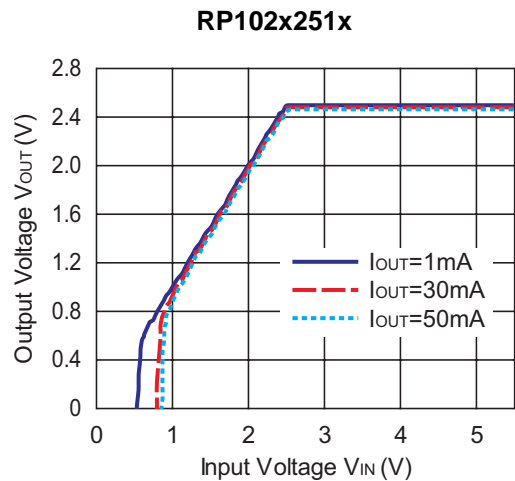
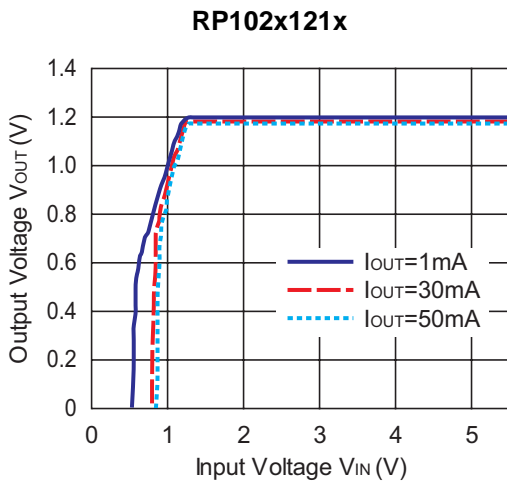

RP102x331x

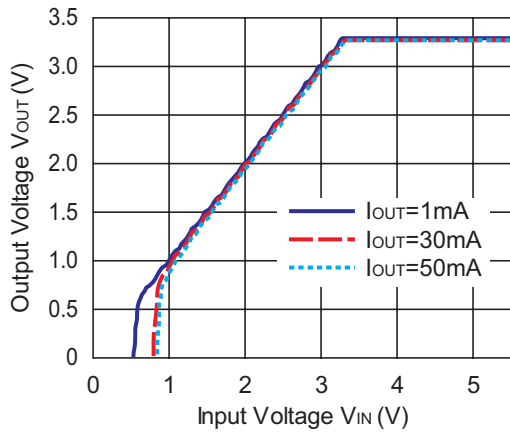

3) Supply Current vs. Input Voltage ( $C_{IN}=1.0\mu F$ ,  $C_{OUT}=1.0\mu F$ ,  $T_{opt}=25^{\circ}C$ )

RP102x121x

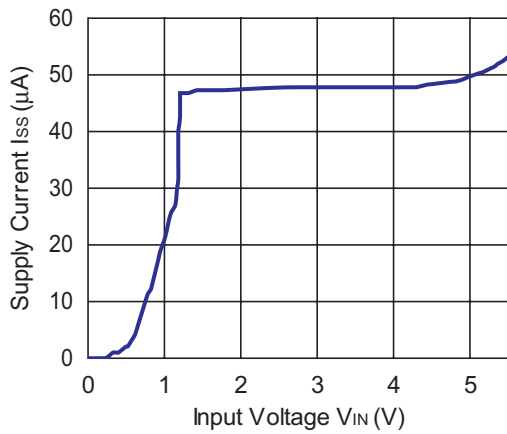

RP102x251x

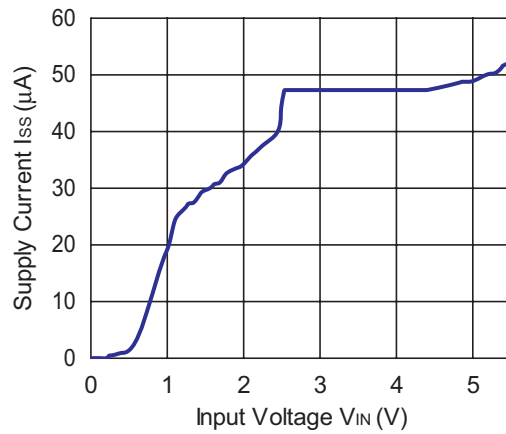

RP102x331x

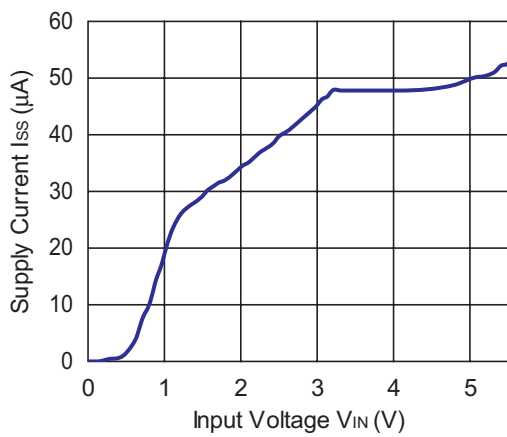

4) Output Voltage vs. Temperature ( $C_{IN}=1.0\mu F$ ,  $C_{OUT}=1.0\mu F$ ,  $I_{OUT}=1mA$ )

RP102x121x

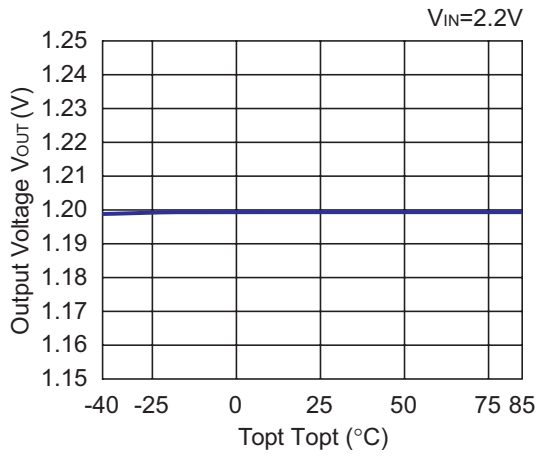

RP102x251x

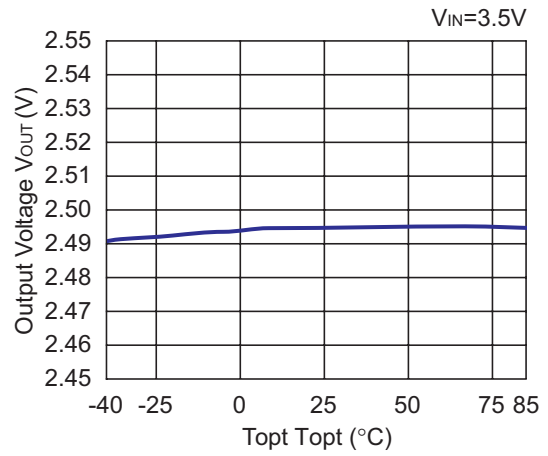

RP102x331x

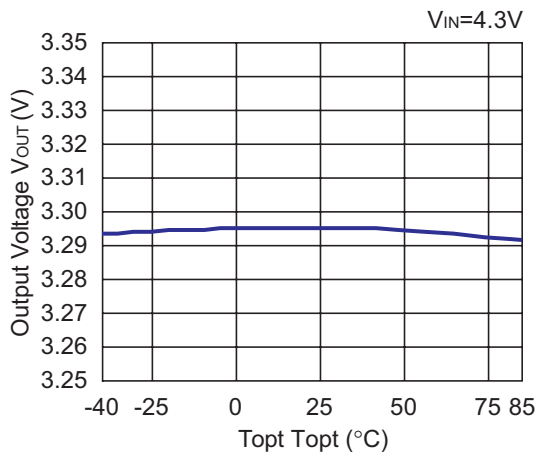

5) Supply Current vs. Temperature ( $C_{IN}=1.0\mu F$ ,  $C_{OUT}=1.0\mu F$ ,  $I_{OUT}=0mA$ )

RP102x121x

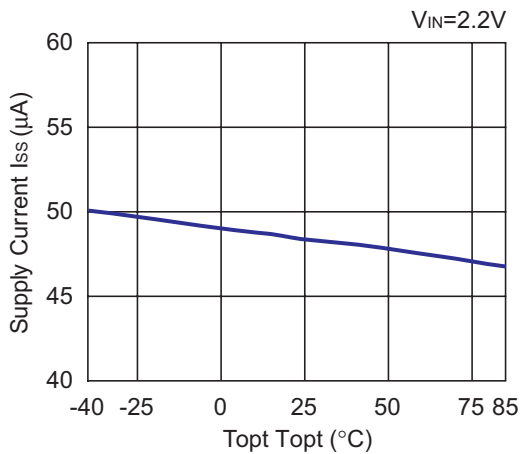

RP102x251x

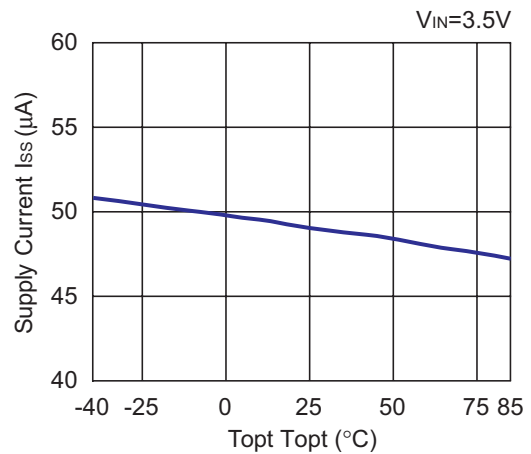

RP102x331x

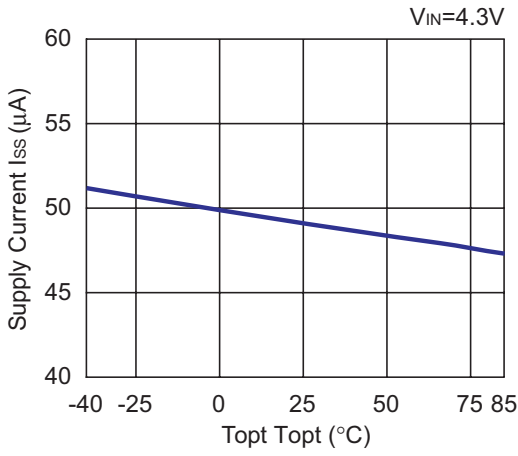

6) Dropout Voltage vs. Output Current ( $C_{IN}=1.0\mu F, C_{OUT}=1.0\mu F$ )

RP102x121x

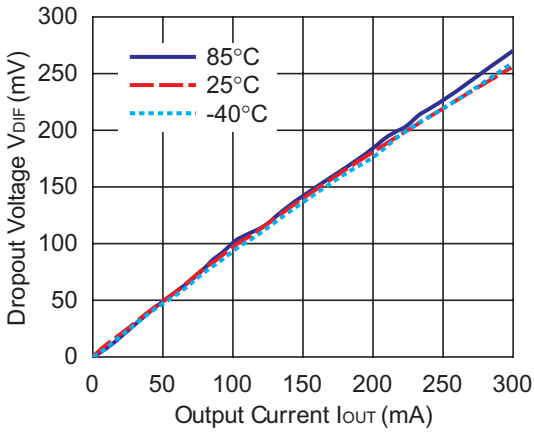

RP102x251x

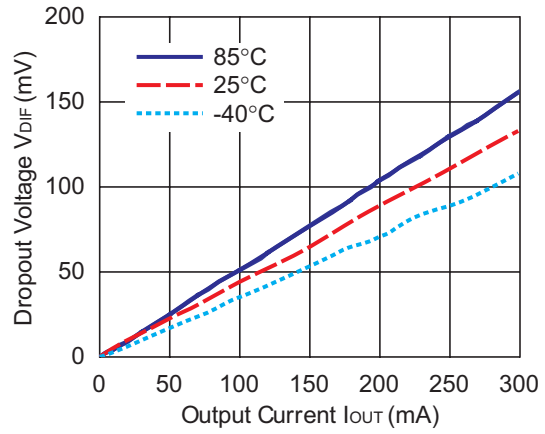

RP102x331x

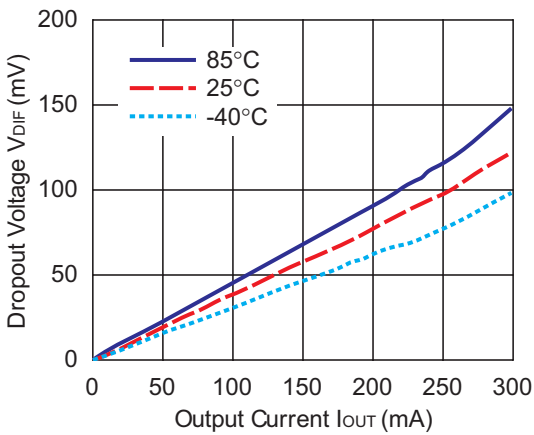

**7) Dropout Voltage vs Set Output Voltage ( $C_{IN}=1.0\mu F$ ,  $C_{OUT}=1.0\mu F$ ,  $T_{opt}=25^{\circ}C$ )**

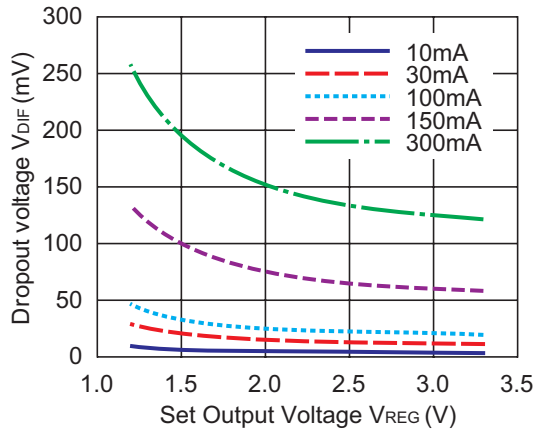

**8) Ripple Rejection vs. Input Bias Voltage ( $C_{IN}=none$ ,  $C_{OUT}=1.0\mu F$ , Ripple  $V_{p-p}=0.2$ ,  $T_{opt}=25^{\circ}C$ )**

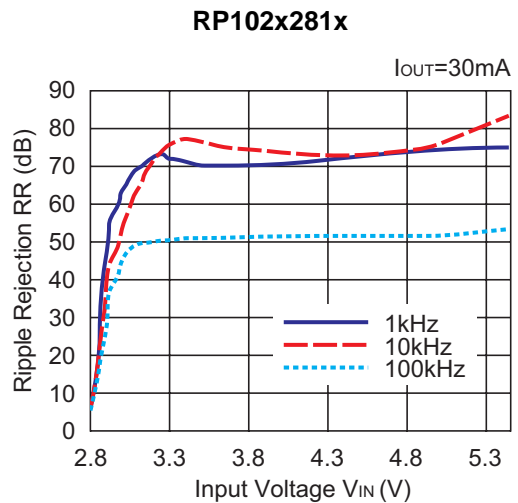
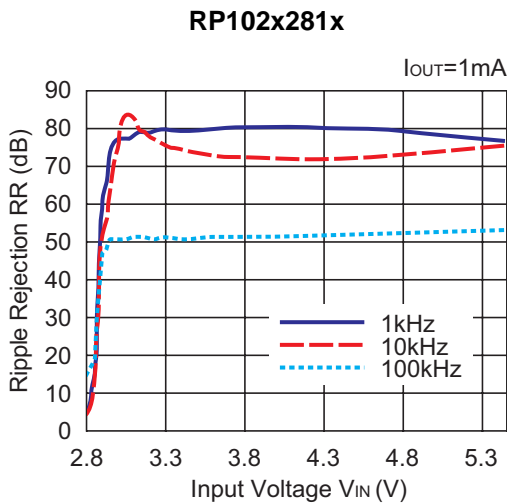
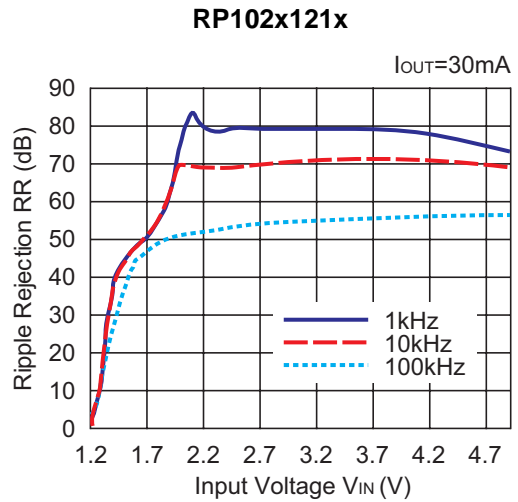
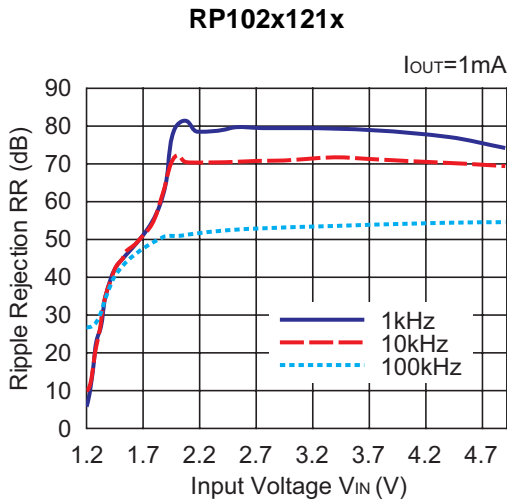

9) Ripple Rejection vs. Frequency ( $C_{IN}=1.0\mu F$ ,  $C_{OUT}=1.0\mu F$ , Ripple Vp-p=0.2)

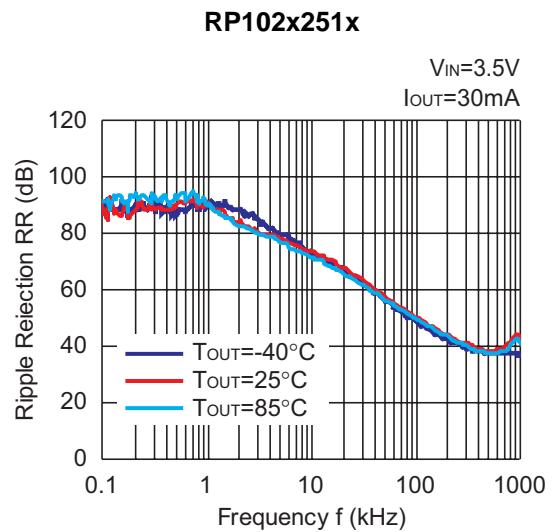
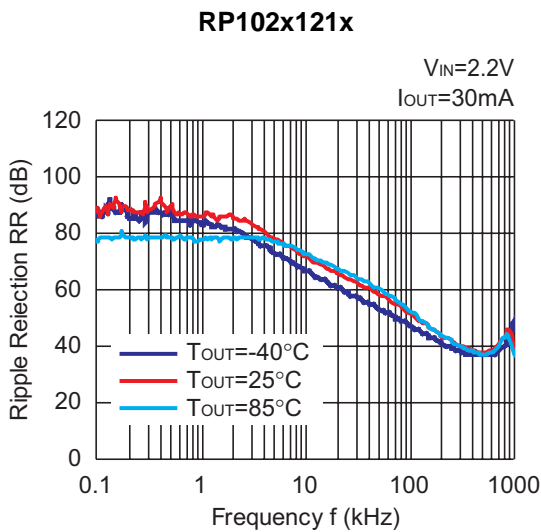
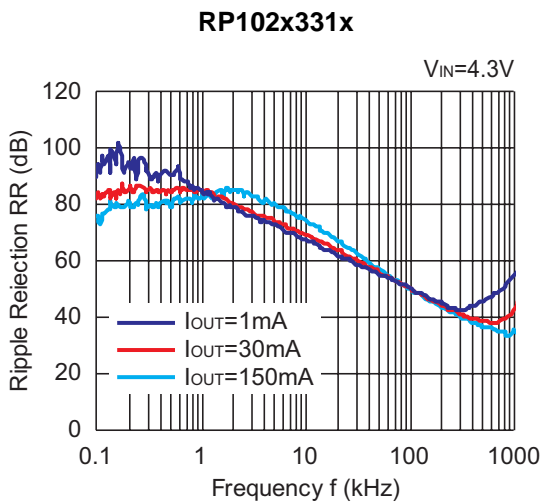
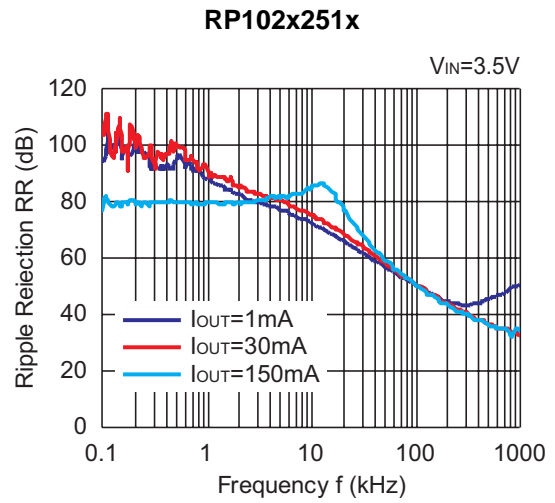
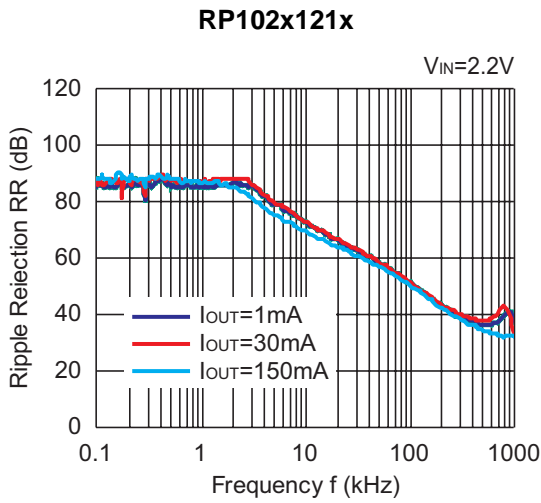

**RP102x331x**

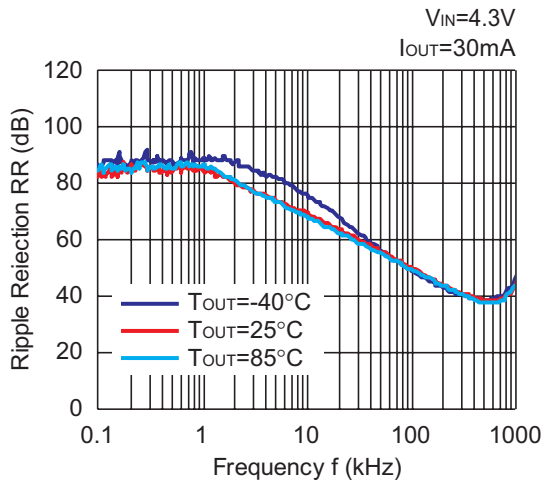

**10) Input Transient Response ( $C_{IN}=\text{none}$ ,  $C_{OUT}=1.0\mu F$ ,  $I_{OUT}=30mA$ ,  $t_r=t_f=5\mu s$ ,  $T_{opt}=25^{\circ}C$ )**

**RP102x121x**

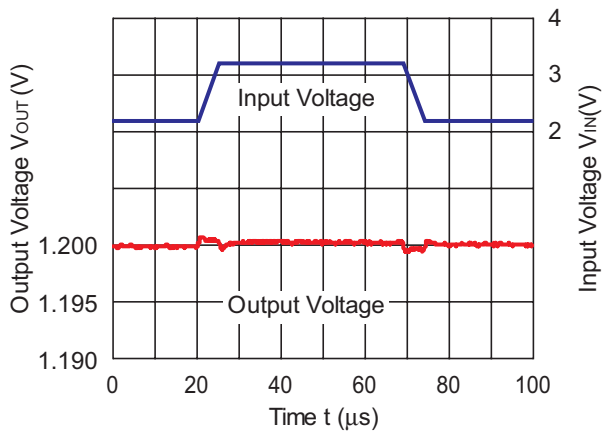

**RP102x251x**

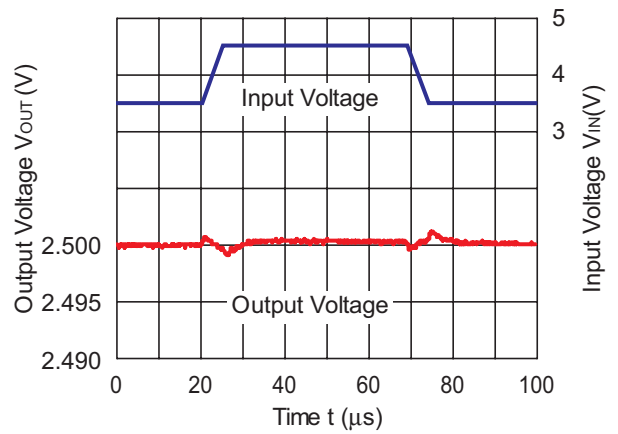

**RP102x331x**

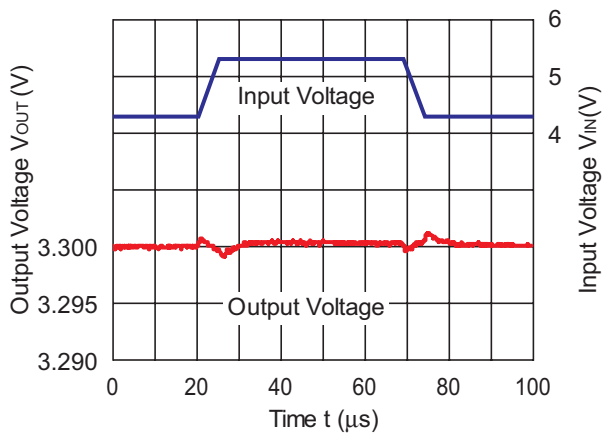

11) Load Transient Response ( $C_{OUT}=1.0\mu F$ ,  $T_{opt}=25^{\circ}C$ )

RP102x121x

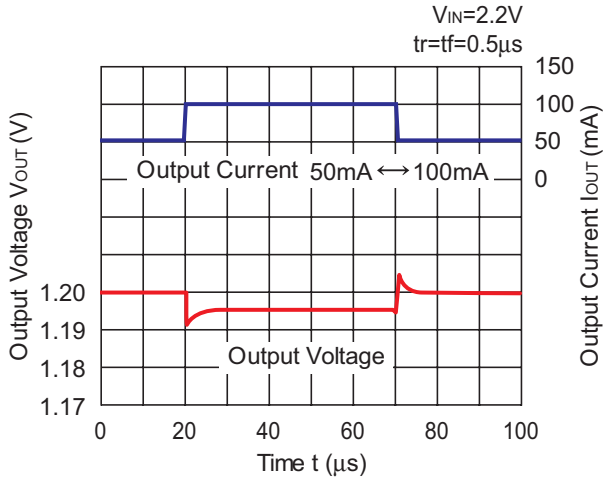

RP102x251x

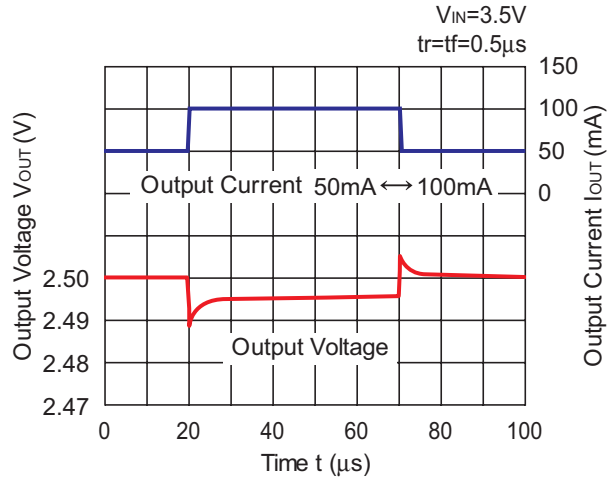

RP102x331x

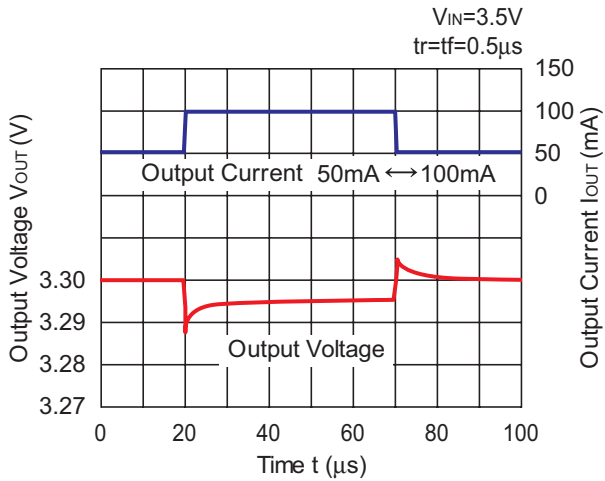

RP102x121x

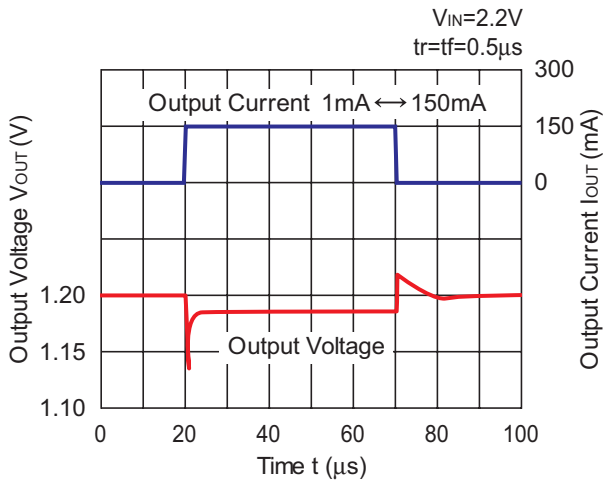

RP102x251x

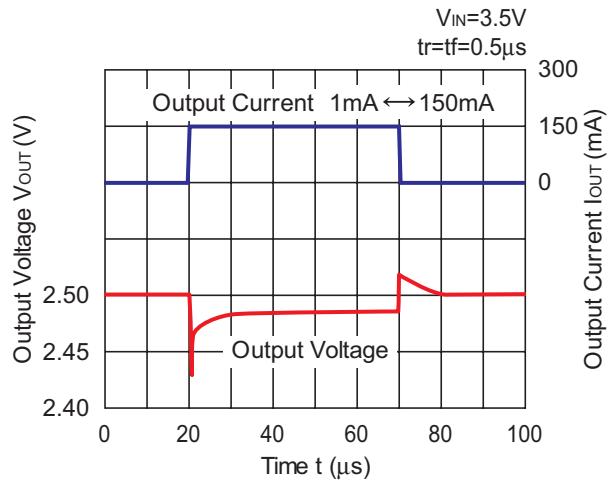



RP102x331x

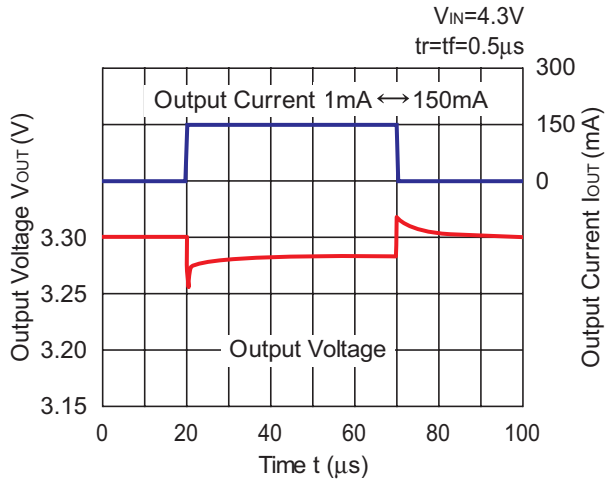

12) Turn On Speed with CE pin ( $C_{IN}=1.0\mu F$ ,  $C_{OUT}=1.0\mu F$ ,  $T_{opt}=25^\circ C$ )

RP102x121x

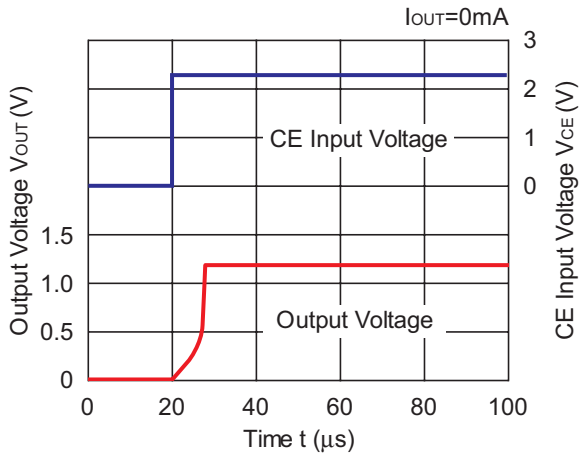

RP102x121x

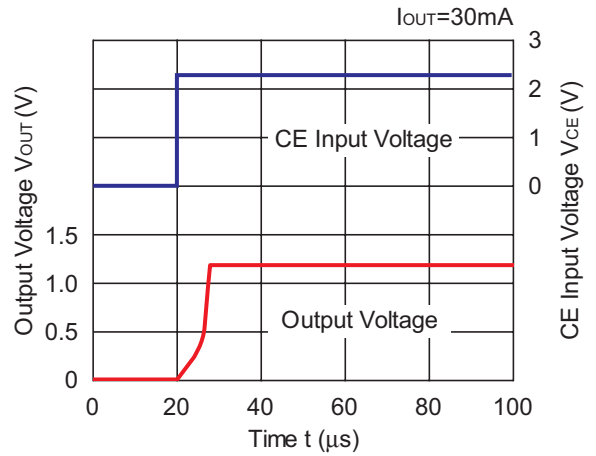

RP102x121x

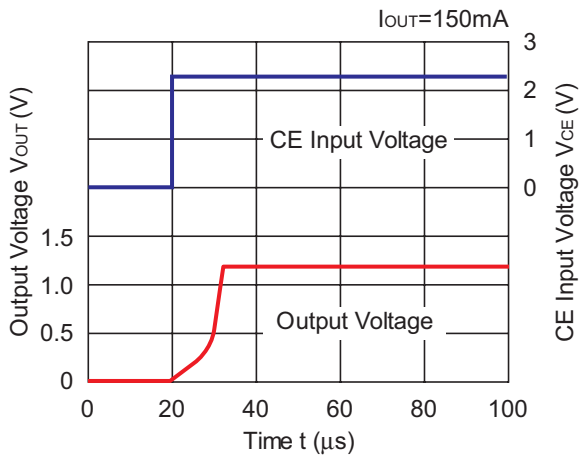

RP102x251x

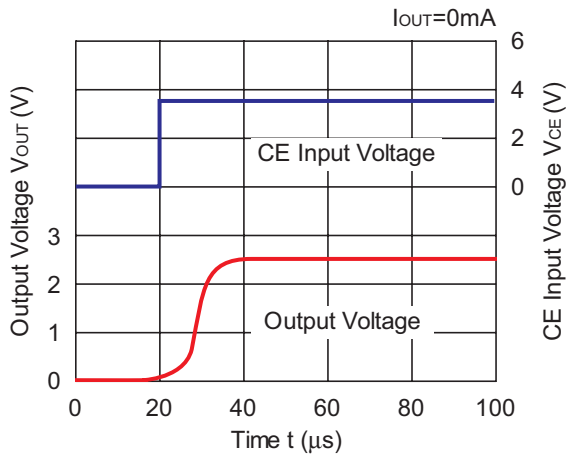

RP102x251x

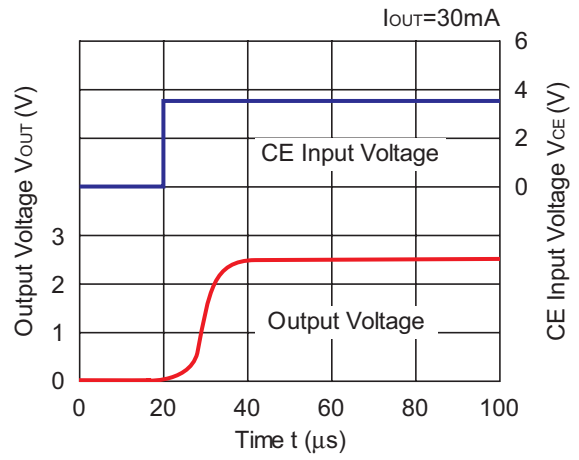

RP102x251x

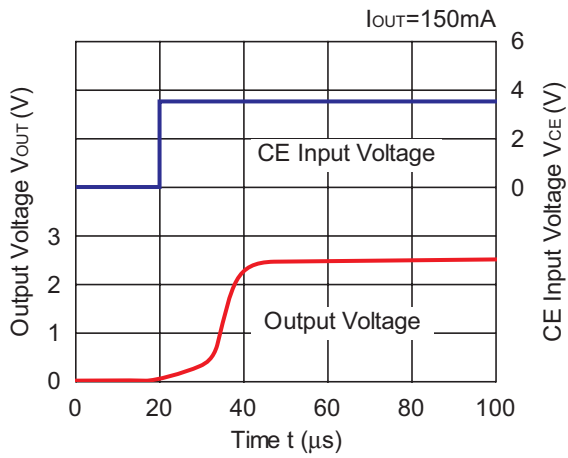

RP102x331x

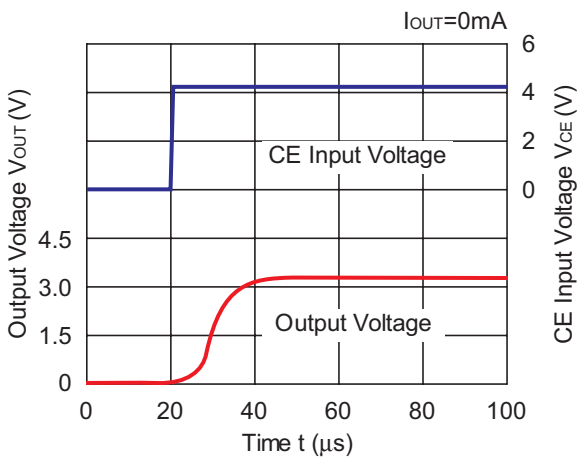

RP102x331x

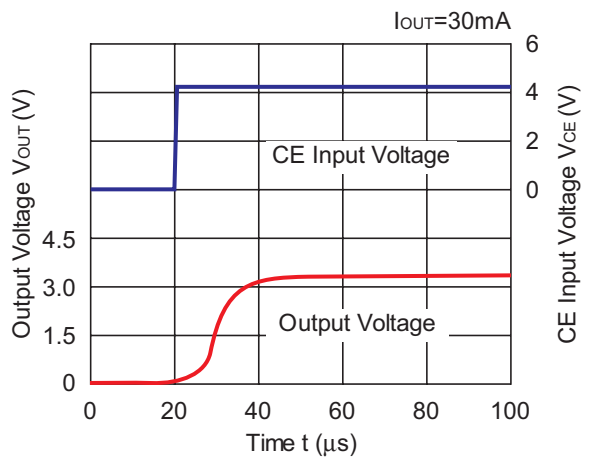

RP102x331x

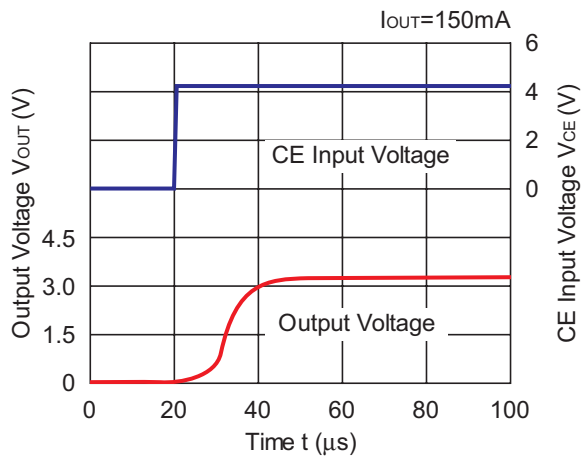

13) Turn OFF Speed with CE pin (D Version) ( $C_{IN}=1.0\mu F$ ,  $C_{OUT}=1.0\mu F$ ,  $T_{opt}=25^{\circ}C$ )

RP102x121D

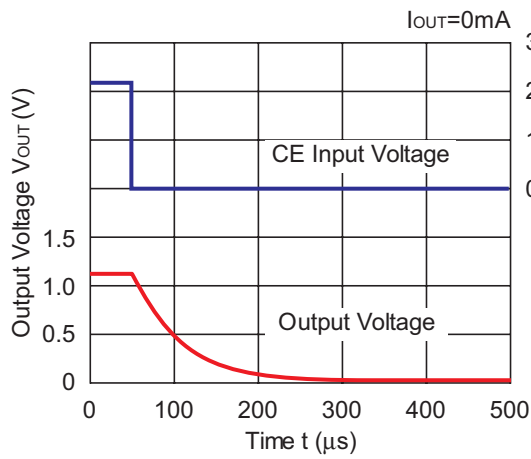

RP102x121D

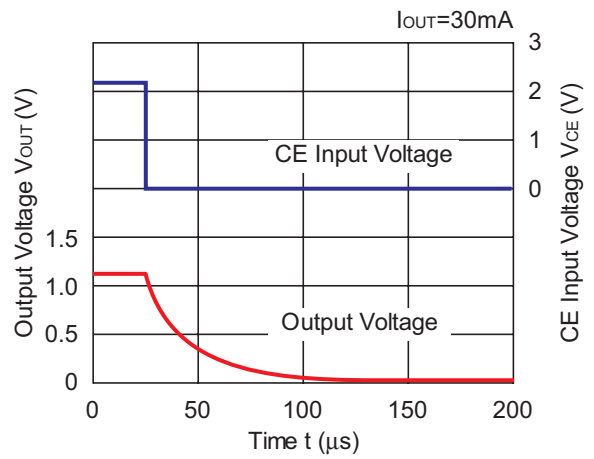

RP102x121D

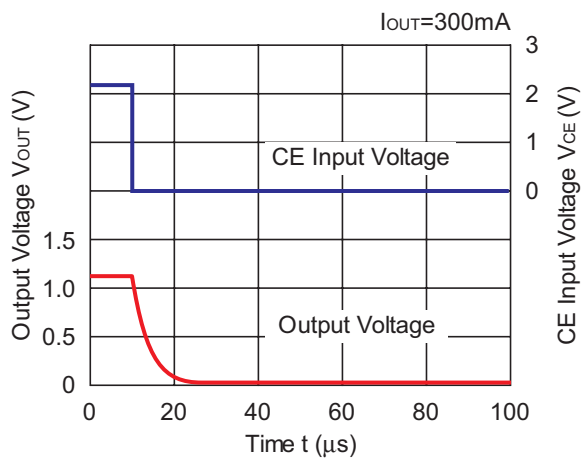

RP102x251x

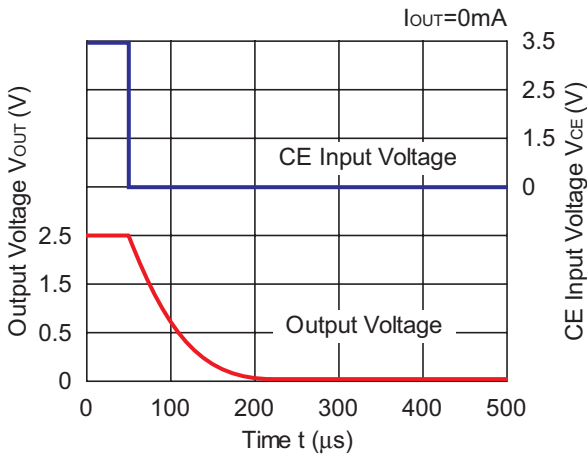

RP102x251x

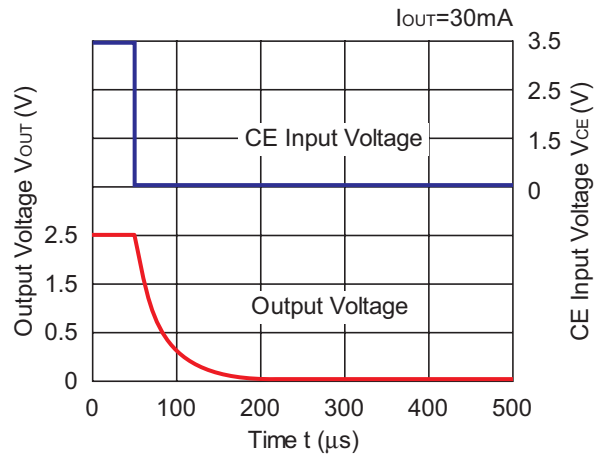

RP102x251x

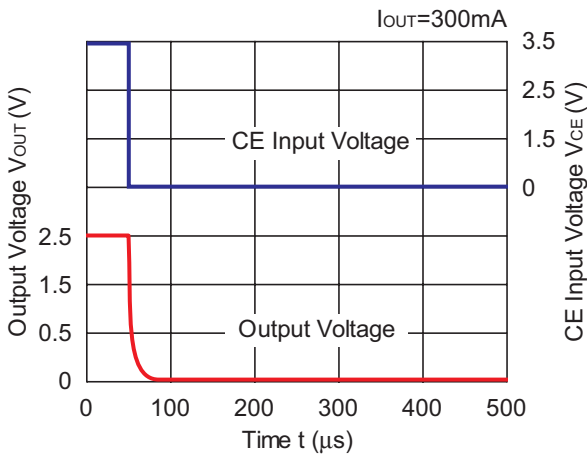

RP102x331x

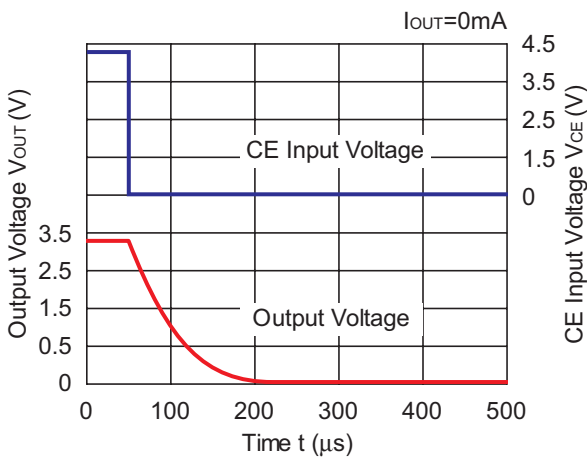

RP102x331x

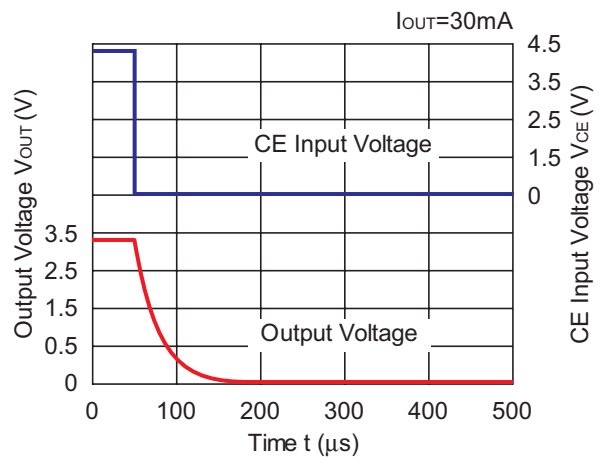

RP102x331x

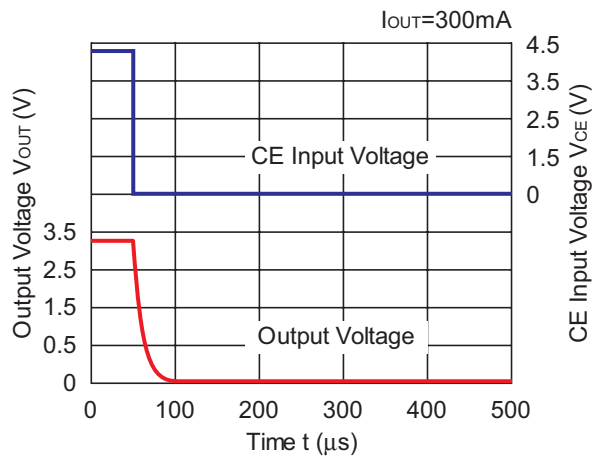

## ESR vs. Output Current

When using these ICs, consider the following points:

The relations between  $I_{OUT}$  (Output Current) and ESR of an output capacitor are shown below.

The conditions when the white noise level is under  $40\mu\text{V}$  (Avg.) are marked as the hatched area in the graph.

### Measurement conditions

Frequency Band: 10Hz to 2MHz

Temperature:  $-40^{\circ}\text{C}$  to  $25^{\circ}\text{C}$

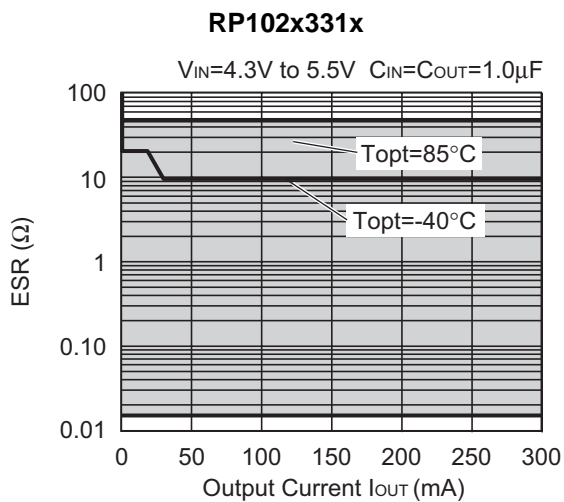
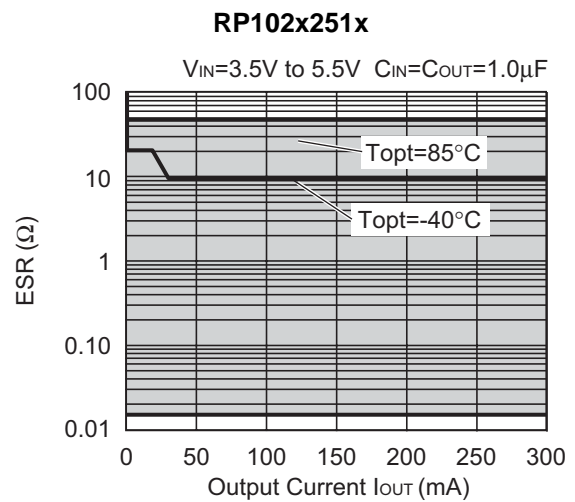
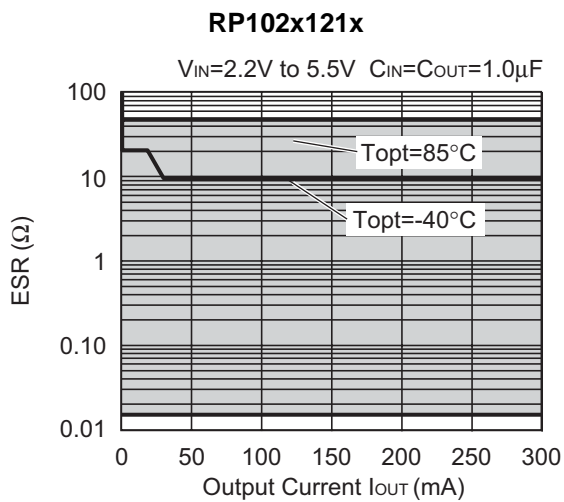

• WLCSP-4-P2

Unit: mm

PACKAGE DIMENSIONS

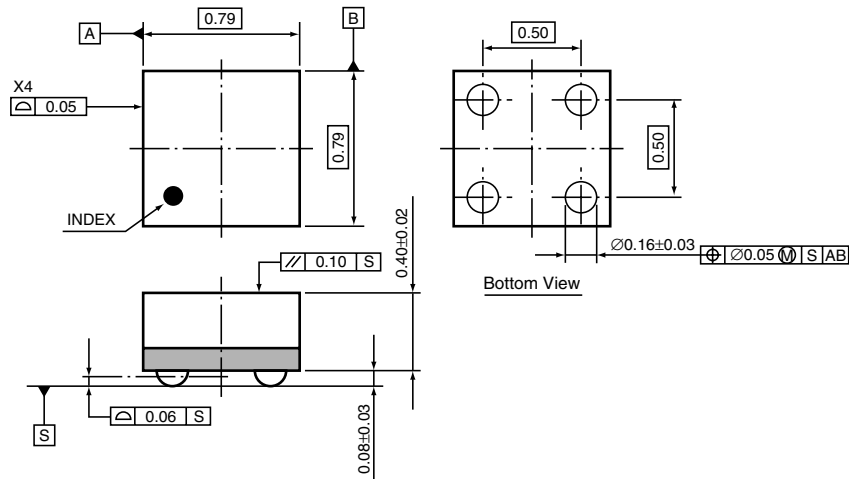

TAPING SPECIFICATION

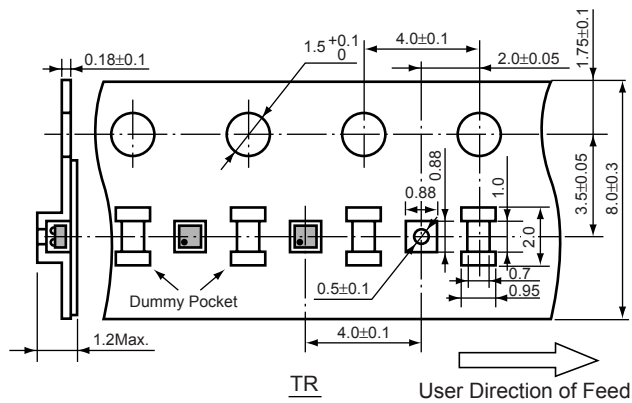

TAPING REEL DIMENSIONS REUSE REEL (EIAJ-RRM-08Bc)

(1reel=3000pcs)

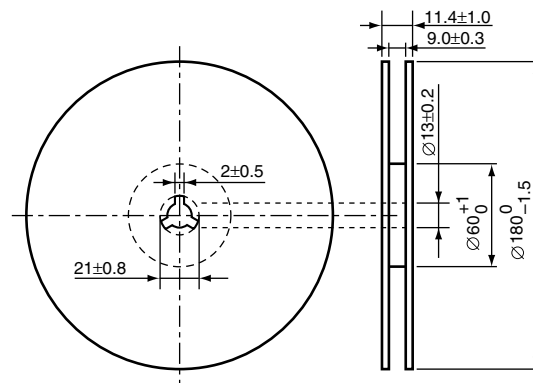

## POWER DISSIPATION (WLCSP-4-P2)

This specification is at mounted on board. Power Dissipation ( $P_D$ ) depends on conditions of mounting on board. This specification is based on the measurement at the condition below:

### Measurement Conditions

	Standard Land Pattern
Environment	Mounting on Board (Wind velocity=0m/s)
Board Material	Glass cloth epoxy plactic (Double sided)
Board Dimensions	40mm × 40mm × 1.6mm
Copper Ratio	Top side : Approx. 50% , Back side : Approx. 50%
Through-hole	-

### Measurement Result

( $T_{opt}=25^{\circ}C, T_{jmax}=125^{\circ}C$ )

	Standard Land Pattern
Power Dissipation	530mW
Thermal Resistance	$\theta_{ja}=(125-25^{\circ}C)/0.53W=189^{\circ}C/W$

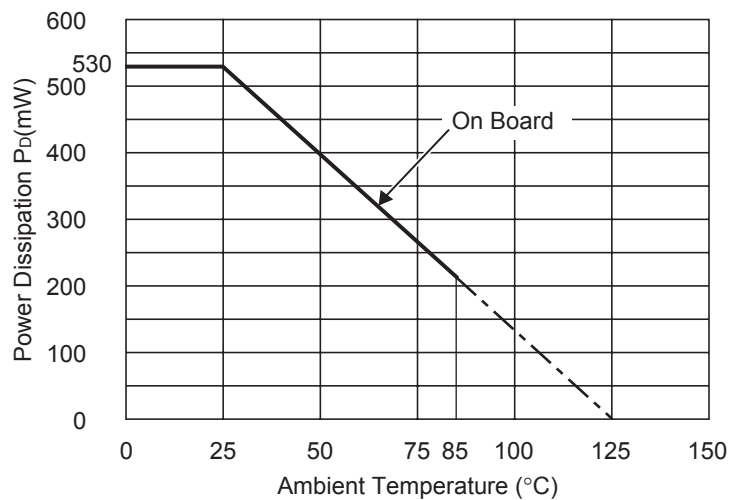

Power Dissipation

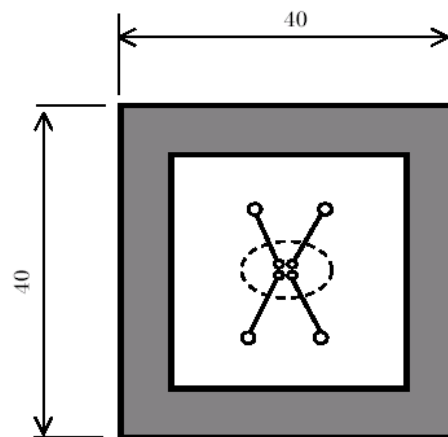

Measurement Board Pattern

○ IC Mount Area (Unit : mm)



**RECOMMENDED LAND PATTERN**

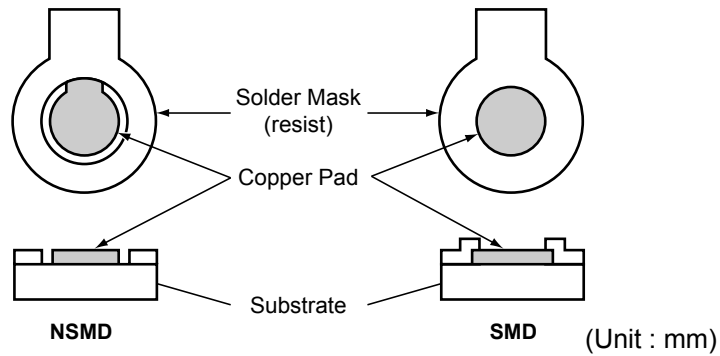

**NSMD and SMD Pad Definition**

Pad definition	Copper Pad	Solder Mask Opening
NSMD (Non-Solder Mask defined)	0.20mm	Min. 0.30mm
SMD (Solder Mask defined)	Min. 0.30mm	0.20mm

- \* Pad layout and size can be modified by customers material, equipment, method.
- \* Please adjust pad layout according to your conditions.
- \* Recommended Stencil Aperture Size....ø0.3mm
- \* Since lead free WL-CSP components are not compatible with the tin/lead solder process, you shall not mount lead free WL-CSP components using the tin/lead solder paste.

• PLP1820-6

Unit: mm

PACKAGE DIMENSIONS

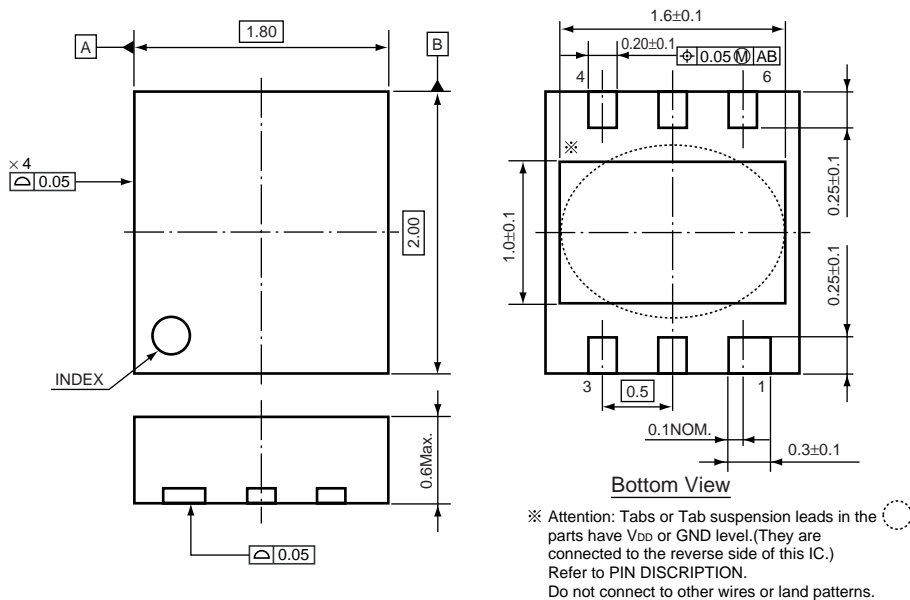

TAPING SPECIFICATION

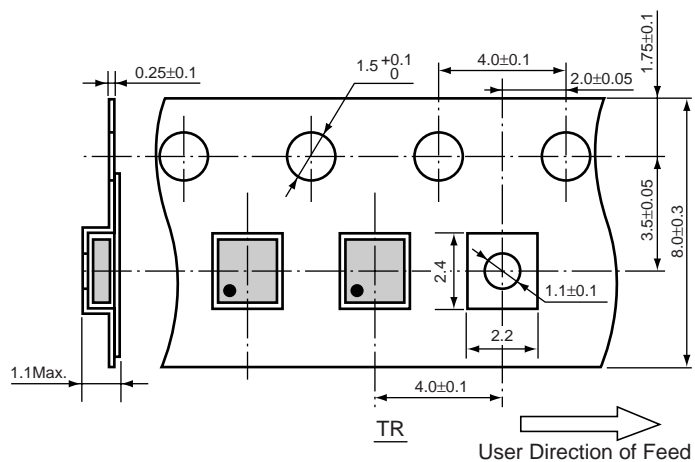

TAPING REEL DIMENSIONS REUSE REEL (EIAJ-RRM-08Bc)

(1reel=5000pcs)

(R5323K,R5325K : 1reel=3000pcs)

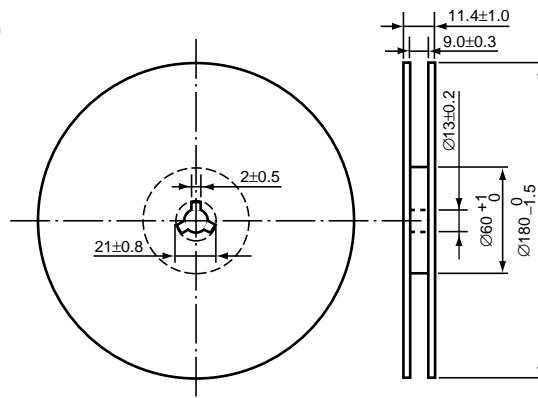

## POWER DISSIPATION (PLP1820-6)

This specification is at mounted on board. Power Dissipation ( $P_D$ ) depends on conditions of mounting on board. This specification is based on the measurement at the condition below:

### Measurement Conditions

	Standard Land Pattern
Environment	Mounting on Board (Wind velocity=0m/s)
Board Material	Glass cloth epoxy plactic (Double sided)
Board Dimensions	40mm × 40mm × 1.6mm
Copper Ratio	Top side : Approx. 50% , Back side : Approx. 50%
Through-hole	φ0.54mm × 30pcs

### Measurement Result

( $T_{opt}=25^{\circ}C, T_{jmax}=125^{\circ}C$ )

	Standard Land Pattern
Power Dissipation	880mW
Thermal Resistance	$\theta_{ja}=(125-25^{\circ}C)/0.88W=114^{\circ}C/W$

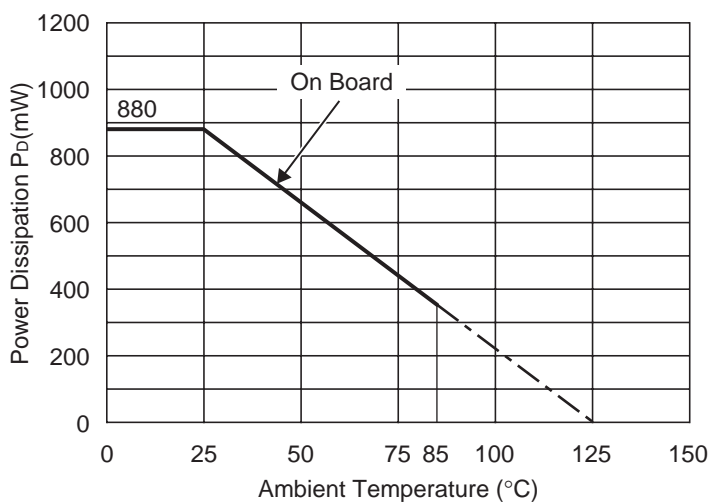

Power Dissipation

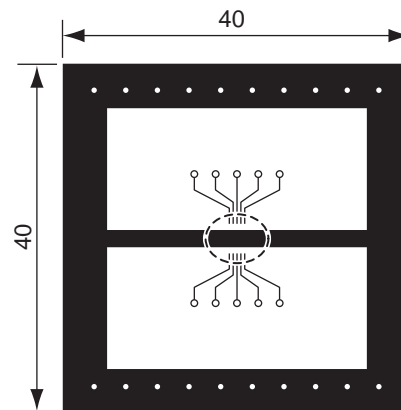

Measurement Board Pattern

○ IC Mount Area Unit : mm

## RECOMMENDED LAND PATTERN

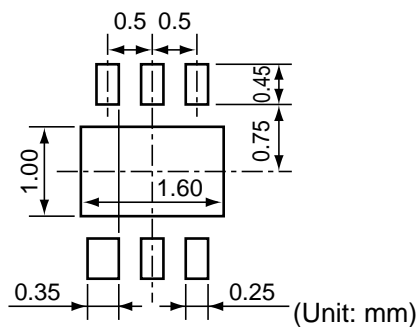

- SOT-23-5 (SC-74A)

Unit: mm

**PACKAGE DIMENSIONS**

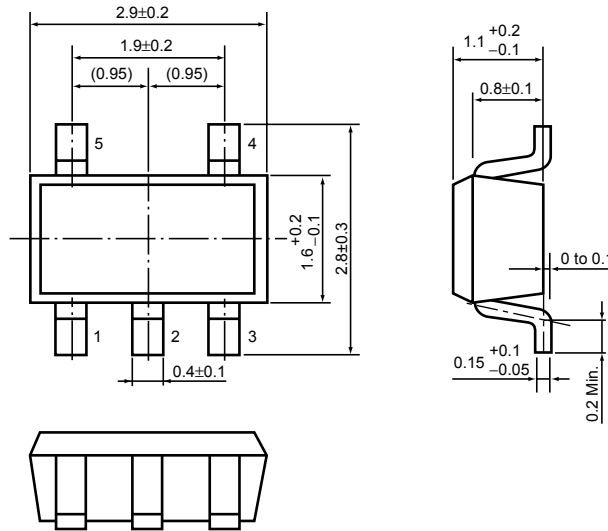

**TAPING SPECIFICATION**

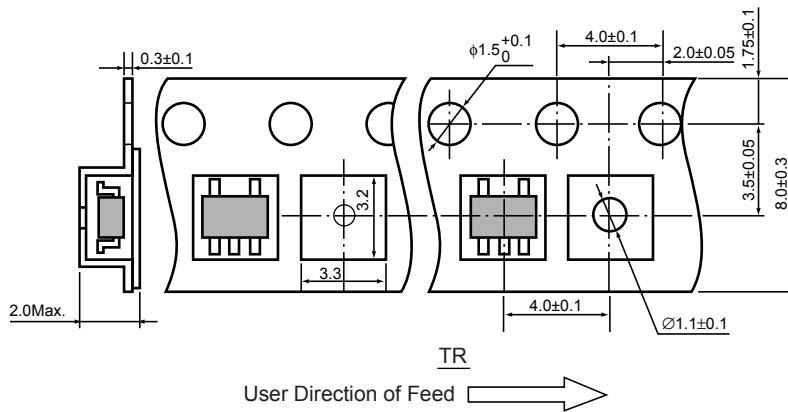

**TAPING REEL DIMENSIONS REUSE REEL (EIAJ-RRM-08Bc)**

(1reel=3000pcs)

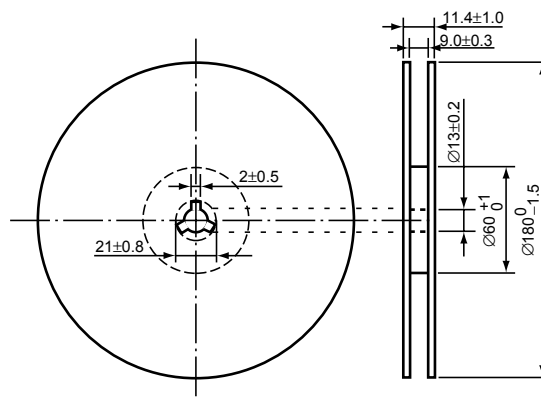

### POWER DISSIPATION (SOT-23-5)

This specification is at mounted on board. Power Dissipation ( $P_D$ ) depends on conditions of mounting on board. This specification is based on the measurement at the condition below:

(Power Dissipation (SOT-23-5) is substitution of SOT-23-6.)

Measurement Conditions

	Standard Land Pattern
Environment	Mounting on Board (Wind velocity=0m/s)
Board Material	Glass cloth epoxy plactic (Double sided)
Board Dimensions	40mm × 40mm × 1.6mm
Copper Ratio	Top side : Approx. 50% , Back side : Approx. 50%
Through-hole	φ0.5mm × 44pcs

Measurement Result

( $T_{opt}=25^{\circ}C, T_{jmax}=125^{\circ}C$ )

	Standard Land Pattern	Free Air
Power Dissipation	420mW	250mW
Thermal Resistance	$\theta_{ja}=(125-25^{\circ}C)/0.42W=263^{\circ}C/W$	400 $^{\circ}C/W$

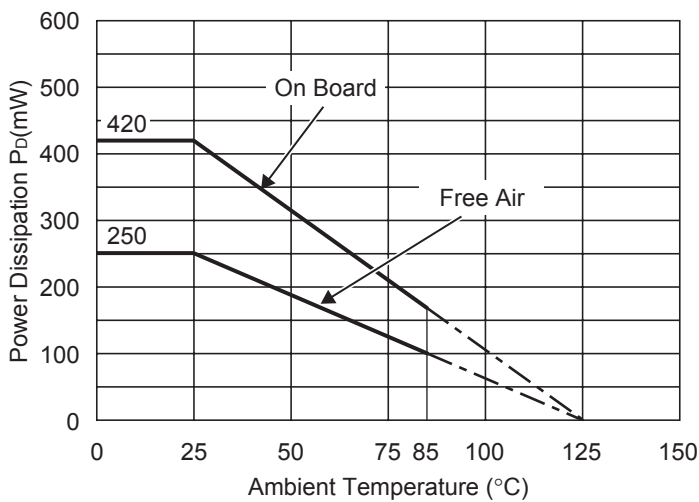

Power Dissipation

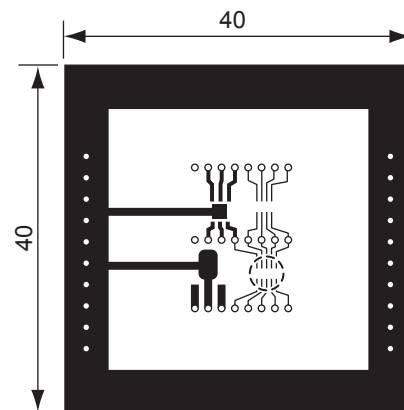

Measurement Board Pattern

○ IC Mount Area Unit : mm

### RECOMMENDED LAND PATTERN

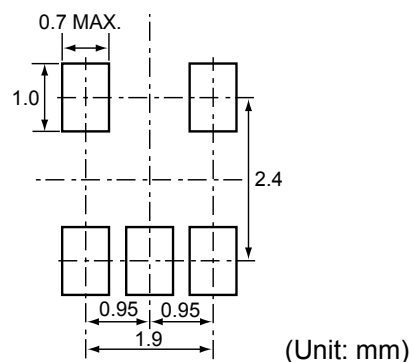

## RP102Z SERIES MARK SPECIFICATION

- WLCSP-4-P2

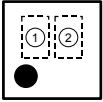

①, ② : Lot Number

(A part number is discriminable from a lot number)

**RP102K SERIES MARK SPECIFICATION**

● **PLP1820-6**

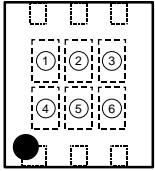

① to ④ : Product Code (refer to Part Number vs. Product Code)  
 ⑤, ⑥ : Lot Number

● **Part Number vs. Product Code**

Part Number	Product Code			
	①	②	③	④
RP102K121B	A	C	0	1
RP102K131B	A	C	0	2
RP102K151B	A	C	0	3
RP102K181B	A	C	0	4
RP102K251B	A	C	0	5
RP102K261B	A	C	0	6
RP102K281B	A	C	0	7
RP102K281B5	A	C	0	8
RP102K291B	A	C	0	9
RP102K301B	A	C	1	0
RP102K331B	A	C	1	1
RP102K181B5	A	C	1	2
RP102K271B	A	C	1	3
RP102K121B5	A	C	1	4

Part Number	Product Code			
	①	②	③	④
RP102K121D	A	D	0	1
RP102K131D	A	D	0	2
RP102K151D	A	D	0	3
RP102K181D	A	D	0	4
RP102K251D	A	D	0	5
RP102K261D	A	D	0	6
RP102K281D	A	D	0	7
RP102K281D5	A	D	0	8
RP102K291D	A	D	0	9
RP102K301D	A	D	1	0
RP102K331D	A	D	1	1
RP102K181D5	A	D	1	2
RP102K271D	A	D	1	3
RP102K121D5	A	D	1	4

**RP102N SERIES MARK SPECIFICATION**

● **SOT-23-5 (SC-74A)**

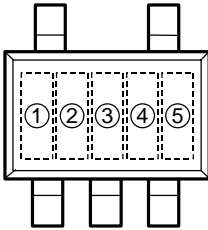

①, ②, ③ : Product Code (refer to Part Number vs. Product Code)  
 ④, ⑤ : Lot Number

● **Part Number vs. Product Code**

Part Number	Product Code		
	①	②	③
RP102N121B	6	0	A
RP102N131B	6	0	B
RP102N151B	6	0	C
RP102N181B	6	0	D
RP102N251B	6	0	E
RP102N261B	6	0	F
RP102N281B	6	0	G
RP102N281B5	6	0	H
RP102N291B	6	0	J
RP102N301B	6	0	K
RP102N331B	6	0	L
RP102N181B5	6	0	M
RP102N271B	6	0	N
RP102N121B5	6	0	P

Part Number	Product Code		
	①	②	③
RP102N121D	6	1	A
RP102N131D	6	1	B
RP102N151D	6	1	C
RP102N181D	6	1	D
RP102N251D	6	1	E
RP102N261D	6	1	F
RP102N281D	6	1	G
RP102N281D5	6	1	H
RP102N291D	6	1	J
RP102N301D	6	1	K
RP102N331D	6	1	L
RP102N181D5	6	1	M
RP102N271D	6	1	N
RP102N121D5	6	1	P