

BYT54M

SINTERED GLASS JUNCTION FAST AVALANCHE RECTIFIER

VOLTAGE: 1000V

CURRENT: 1.25A



FEATURE

Glass passivated
Hermetically sealed package
Low reverse current
Soft recovery characteristics

MECHANICAL DATA

Case: SOD-57 sintered glass case
Terminal: Plated axial leads solderable per MIL-STD 202E, method 208C
Polarity: color band denotes cathode end
Mounting position: any

SOD-57

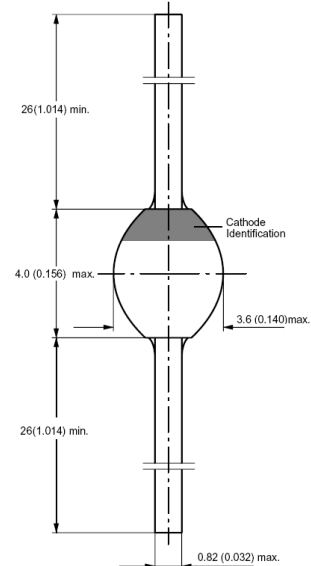

Dimensions in inches and (millimeters)

MAXIMUM RATINGS AND ELECTRICAL CHARACTERISTICS

(single-phase, half-wave, 60HZ, resistive or inductive load rating at 25°C, unless otherwise stated)

	SYMBOL	BYT54M	units
Maximum Recurrent Peak Reverse Voltage	V_{RRM}	1000	V
Maximum RMS Voltage	V_{RMS}	700	V
Maximum DC blocking Voltage	V_{DC}	1000	V
Maximum Average Forward Rectified Current 3/8" lead length at $l = 10\text{mm}$	I_{FAV}	1.25	A
Peak Forward Surge Current at $t_p = 10\text{ms}$, half sinewave	I_{FSM}	30	A
Maximum Forward Voltage at rated Forward Current at $I_F = 1.0\text{A}$	V_F	1.5	V
Non-repetitive peak reverse avalanche energy at $I_{BR(R)} = 0.4\text{A}$	E_{RSM}	10	mJ
Maximum DC Reverse Current at rated DC blocking voltage	I_R	5.0 150.0	μA μA
Maximum Reverse Recovery Time (Note 1)	T_{rr}	100	nS
Typical Thermal Resistance (Note 2)	$R_{th(ja)}$	100	$^{\circ}\text{C}/\text{W}$
Storage and Operating Junction Temperature	T_{stg}, T_j	-65 to +175	$^{\circ}\text{C}$

Note:

- Reverse Recovery Condition $I_f = 0.5\text{A}$, $I_r = 1.0\text{A}$, $I_{rr} = 0.25\text{A}$
- on PC board with spacing 25 mm

RATINGS AND CHARACTERISTIC CURVES BYT54M

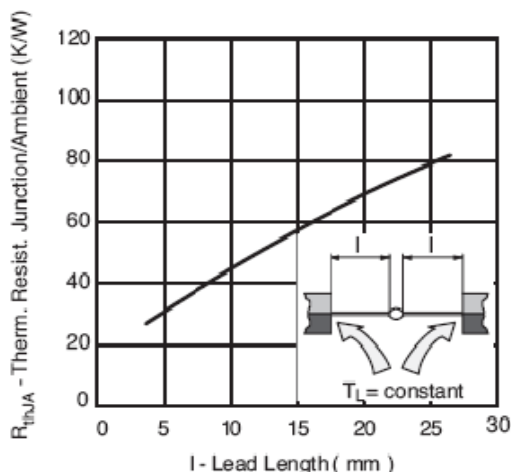

Figure 1. Max. Thermal Resistance vs. Lead Length

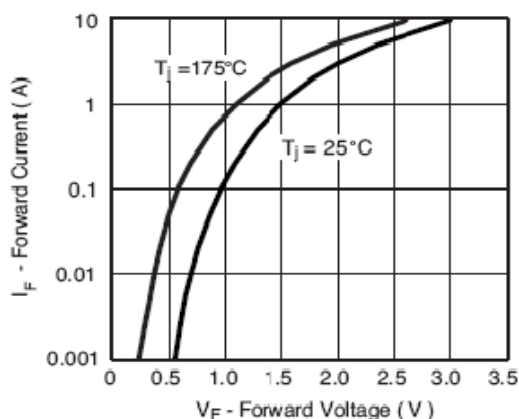

Figure 2. Forward Current vs. Forward Voltage

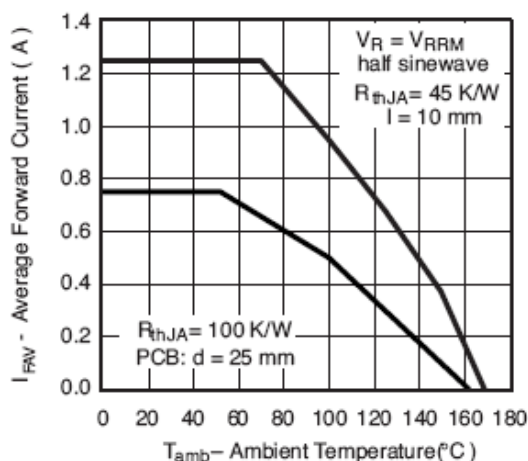

Figure 3. Max. Average Forward Current vs. Ambient Temperature

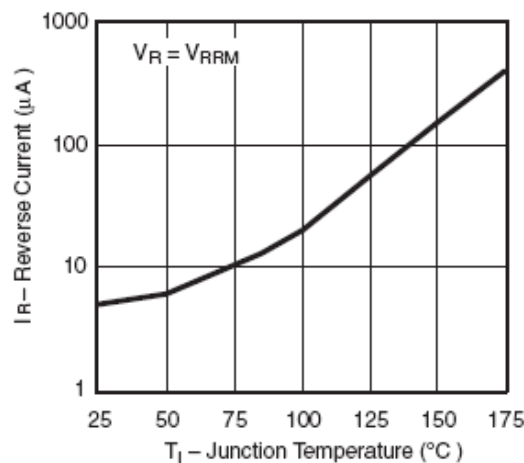

Figure 4. Reverse Current vs. Junction Temperature

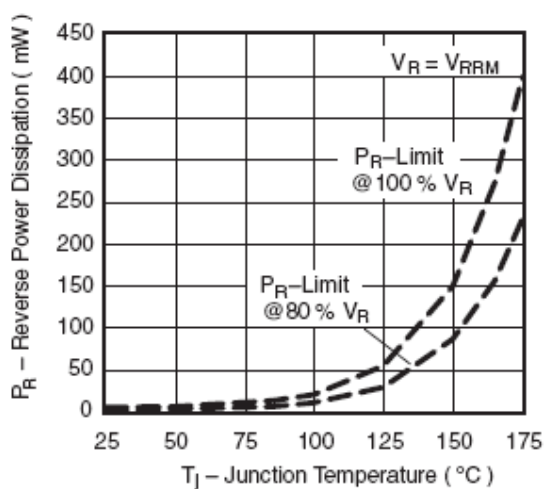

Figure 5. Max. Reverse Power Dissipation vs. Junction Temperature

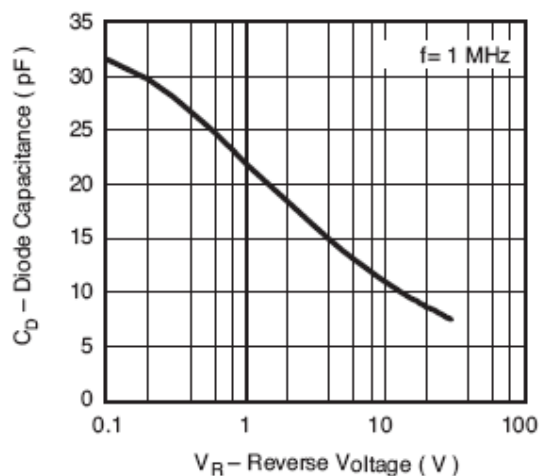

Figure 6. Diode Capacitance vs. Reverse Voltage