

RoHS Compliant Product

A suffix of "-C" specifies halogen & lead-free

TO-92 MOD

**FEATURE**

Power dissipation

$P_{CM}$ : 1 W ( $T_{amb}=25^{\circ}C$ )

Collector current

$I_{CM}$ : 1 A

Collector-base voltage

$V_{(BR)CBO}$ : 2SC1383: 30 V  
2SC1384: 50 V

Operating and storage junction temperature range

$T_J, T_{stg}$ :  $-55^{\circ}C$  to  $+150^{\circ}C$

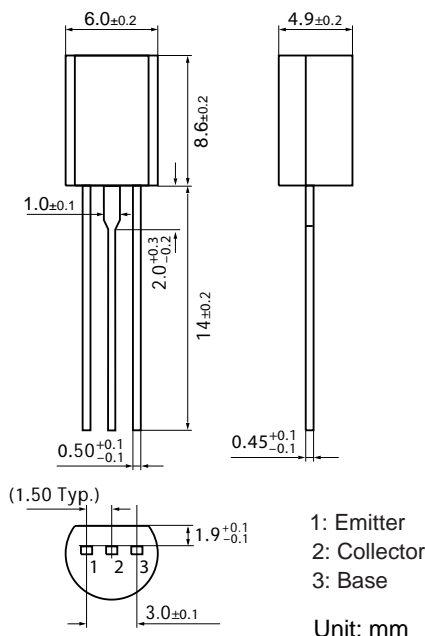

**ELECTRICAL CHARACTERISTICS ( $T_{amb}=25^{\circ}C$  unless otherwise specified)**

Parameter	Symbol	Test conditions	MIN	MAX	UNIT
Collector-base breakdown voltage	2SC1383	$I_C=10\mu A, I_E=0$	30		V
	2SC1384		60		
Collector-emitter breakdown voltage	2SC1383	$I_C=2mA, I_B=0$	25		V
	2SC1384		50		
Emitter-base breakdown voltage	$V_{(BR)EBO}$	$I_E=10\mu A, I_C=0$	5		V
Collector cut-off current	$I_{CBO}$	$V_{CB}=20V, I_E=0$		0.1	$\mu A$
DC current gain	$h_{FE(1)}$	$V_{CE}=10V, I_C=500mA$	85	340	
	$h_{FE(2)}$	$V_{CE}=5V, I_C=1A$	50		
Collector-emitter saturation voltage	$V_{CE(sat)}$	$I_C=500mA, I_B=50mA$		0.4	V
Base-emitter saturation voltage	$V_{BE(sat)}$	$I_C=500mA, I_B=50mA$		1.2	V
Transition frequency	$f_T$	$V_{CE}=10V, I_C=50mA$	100		MHz

**CLASSIFICATION OF  $h_{FE(1)}$**

Rank	Q	R	S
Range	85-170	120-240	170-340

