

General Description

The AAT1231/1231-1 are high frequency, high efficiency constant current boost converters capable of 24V maximum output voltage. Both devices are ideal power solutions for backlight applications with up to six white LEDs in series or up to twelve white LEDs in a parallel/series configuration. The input voltage is 2.7V to 5.5V for single-cell lithium-ion/polymer (Li-ion) based portable devices.

The LED current is digitally controlled across a 6x operating range using AnalogicTech's Simple Serial Control™ (S²Cwire™) interface. Programmability across 26 discrete current steps provides high resolution, low noise, flicker-free, constant LED outputs. In programming AAT1231 operation, LED brightness increases based on the data received at the EN/SET pin. In programming AAT1231-1 operation, LED brightness decreases based on the data received at the EN/SET pin. The SEL logic pin changes the feedback voltage between two programmable ranges.

The AAT1231 and the AAT1231-1 feature high current limit and fast, stable transitions for stepped or pulsed current applications. The high switching frequency (up to 2MHz) provides fast response and allows the use of ultra-small external components, including chip inductors and capacitors. Fully integrated control circuitry simplifies design and reduces total solution size. The AAT1231 and the AAT1231-1 offer a true load disconnect feature which isolates the load from the power source while in the OFF or disabled state. This eliminates leakage current, making the devices ideally suited for battery-powered applications.

The AAT1231 and the AAT1231-1 are available in Pb-free, thermally-enhanced 12-pin TSOPJW packages.

Features

- Input Voltage Range: 2.7V to 5.5V
- Maximum Continuous Output 24V @ 50mA
- Drives 6 LEDs in Series, 12 LEDs in Parallel / Series Configuration
 - Constant LED Current with 6% Accuracy
- Digital Control with S²Cwire Single Wire Interface
 - 26 Discrete Steps
 - No PWM Control Required
 - No Additional Circuitry
- Up to 82% Efficiency
- Up to 2MHz Switching Frequency Allows Small External Chip Inductor and Capacitors
- Hysteretic Control
 - No External Compensation Components
 - Excellent Load Transient Response
 - High Efficiency at Light Loads
- Integrated Soft Start with No External Capacitor
- True Load Disconnect Guarantees <1.0µA Shutdown Current
- Selectable Feedback Voltage Ranges for High Resolution Control of Load Current
- Short-Circuit, Over-Voltage, and Over-Temperature Protection
- 12-Pin TSOPJW Package
- -40°C to +85°C Temperature Range

Applications

- Digital Still Cameras (DSCs)
- Mobile Handsets
- MP3 Players
- PDAs and Notebook PCs
- White LED Drivers

Typical Application

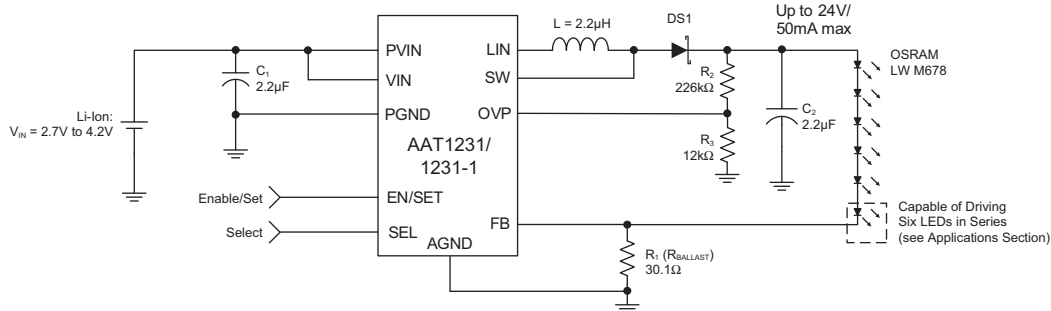

Pin Descriptions

Pin #	Symbol	Function
1	PVIN	Input power pin; connected to the source of the P-channel MOSFET. Connect to the input capacitor(s).
2	EN/SET	IC enable pin and S ² Cwire input control to set output current.
3	SEL	FB voltage range select. For the AAT1231, a logic LOW sets the FB voltage range from 0.1V to 0.4V; a logic HIGH sets the FB voltage range from 0.3V to 0.6V. For the AAT1231-1, a logic LOW sets the FB voltage range from 0.4V to 0.1V; a logic HIGH sets the FB voltage range from 0.6V to 0.3V.
4	VIN	Input voltage for the converter. Connect directly to the PVIN pin.
5	N/C	No connection.
6, 7	SW	Boost converter switching node. Connect the power inductor between this pin and LIN.
8	PGND	Power ground for the boost converter.
9	AGND	Ground pin.
10	FB	Feedback pin. Connect a resistor to ground to set the maximum LED current.
11	OVP	Feedback pin for over-voltage protection sense.
12	LIN	Switched power input. Connect the power inductor between this pin and SW.

Pin Configuration

**TSOPJW-12
(Top View)**

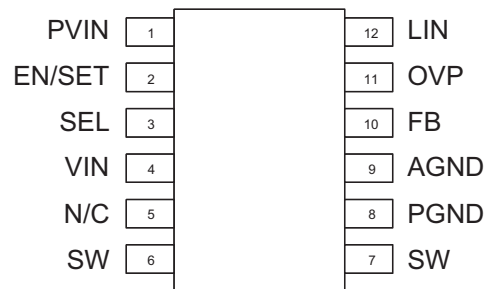

Part Number Descriptions

Part Number	SEL Polarity		S ² Cwire Feedback Voltage Programming
	HIGH	LOW	
AAT1231ITP	$0.3V \leq V_{FB} \leq 0.6V$	$0.1V \leq V_{FB} \leq 0.4V$	See Table 2
AAT1231ITP-1	$0.6V \geq V_{FB} \geq 0.3V$	$0.4V \geq V_{FB} \geq 0.1V$	See Table 3

Absolute Maximum Ratings¹

T_A = 25°C unless otherwise noted.

Symbol	Description	Value	Units
PVIN, VIN	Input Voltage	-0.3 to 6.0	V
SW	Switching Node	28	V
LIN, EN/SET, SEL, FB	Maximum Rating	V _{IN} + 0.3	V
T _J	Operating Temperature Range	-40 to 150	°C
T _S	Storage Temperature Range	-65 to 150	°C
T _{LEAD}	Maximum Soldering Temperature (at leads, 10 sec)	300	°C

Thermal Information

Symbol	Description	Value	Units
θ _{JA}	Thermal Resistance	160	°C/W
P _D	Maximum Power Dissipation	625	mW

1. Stresses above those listed in Absolute Maximum Ratings may cause permanent damage to the device. Functional operation at conditions other than the operating conditions specified is not implied. Only one Absolute Maximum Rating should be applied at any one time.

Electrical Characteristics¹

T_A = -40°C to +85°C unless otherwise noted. Typical values are at 25°C, V_{IN} = 3.6V.

Symbol	Description	Conditions	Min	Typ	Max	Units
Power Supply						
PV _{IN} , V _{IN}	Input Voltage Range		2.7		5.5	V
V _{OUT(MAX)}	Maximum Output Voltage				24	V
I _Q	Operating Current	SEL = GND, FB = 0.1V		40	70	μA
I _{SHDN}	Shutdown Current	EN/SET = GND			1.0	μA
I _{OUT}	Maximum Continuous Output Current ²	2.7V < V _{IN} < 5.5V, V _{OUT} = 24V			50	mA
$\frac{\Delta V_{\text{LINEREG(FB)}}}{\Delta V_{\text{IN}}}$	Line Regulation	V _{IN} = 2.7V to 5.5V, V _{FB} = 0.6V		0.7		%/V
R _{DS(ON) L}	Low Side Switch On Resistance			80		mΩ
T _{SS}	Soft-Start Time	From Enable to Output Regulation; V _{FB} = 300mV		300		μs
V _{OV}	Over-Voltage Protection Threshold	V _{OUT} Rising	1.1	1.2	1.3	V
	Over-Voltage Hysteresis	V _{OUT} Falling		100		mV
I _{LIMIT}	N-Channel Current Limit			2.5		A
T _{SD}	T _J Thermal Shutdown Threshold			140		°C
T _{HYS}	T _J Thermal Shutdown Hysteresis			15		°C
SEL, EN/SET						
V _{SEL(L)}	SEL Threshold Low				0.4	V
V _{SEL(H)}	SEL Threshold High		1.4			V
V _{EN/SET(L)}	Enable Threshold Low				0.4	V
V _{EN/SET(H)}	Enable Threshold High		1.4			V
T _{EN/SET (LO)}	EN/SET Low Time	V _{EN/SET} < 0.6V	0.3		75	μs
T _{EN/SET(HI)}	EN/SET High Time	V _{EN/SET} > 1.4V			75	μs
T _{OFF}	EN/SET Off Timeout	V _{EN/SET} < 0.6V			500	μs
T _{LAT}	EN/SET Latch Timeout	V _{EN/SET} > 1.4V			500	μs
I _{EN/SET}	EN/SET Input Leakage	V _{EN/SET} = 5V, V _{IN} = 5V	-1		1	μA
AAT1231						
FB	FB Pin Regulation	V _{IN} = 2.7V to 5.5V, SEL = GND, EN/SET = HIGH	0.09	0.1	0.11	V
		V _{IN} = 2.7V to 5.5V, SEL = HIGH, EN/SET = DATA16	0.564	0.6	0.636	
AAT1231-1						
FB	FB Pin Regulation	V _{IN} = 2.7V to 5.5V, SEL = GND, EN/SET = DATA16	0.09	0.1	0.11	V
		V _{IN} = 2.7V to 5.5V, SEL = HIGH, EN/SET = HIGH	0.564	0.6	0.636	

1. Specification over the -40°C to +85°C operating temperature range is assured by design, characterization, and correlation with statistical process controls.
 2. Maximum continuous output current increases with reduced output voltage, but may vary depending on operating efficiency and thermal limitations.

Typical Characteristics

Efficiency vs. LED Current
(4 White LEDs; $R_{BALLAST} = 30.1\Omega$)

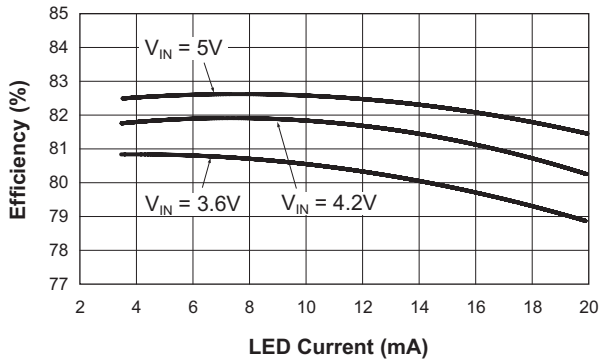

Efficiency vs. LED Current
(5 White LEDs; $R_{BALLAST} = 30.1\Omega$)

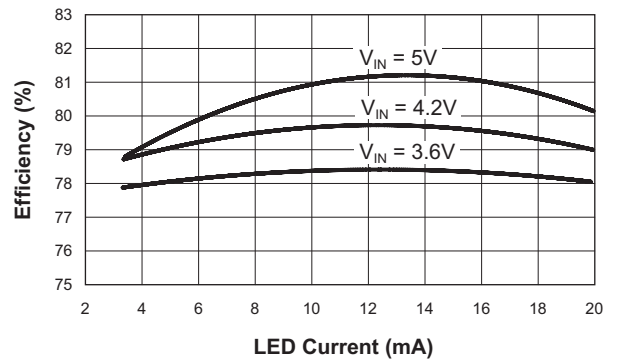

Efficiency vs. LED Current
(6 White LEDs; $R_{BALLAST} = 30.1\Omega$)

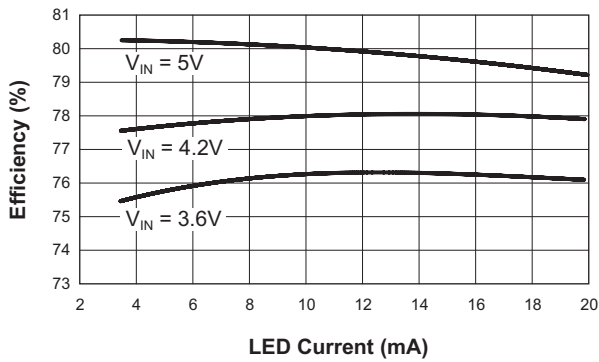

Efficiency vs. LED Current
(12 White LEDs; $R_{BALLAST} = 30.1\Omega$)

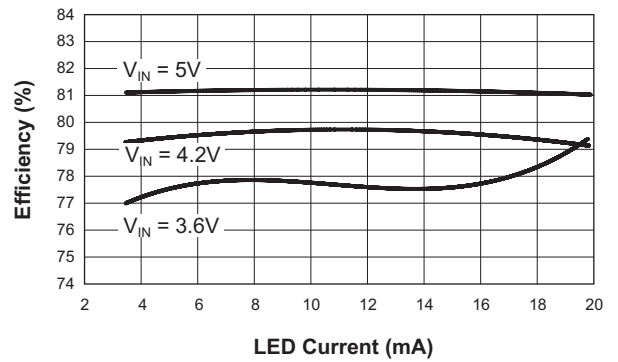

Shutdown Current vs. Input Voltage
(EN = GND)

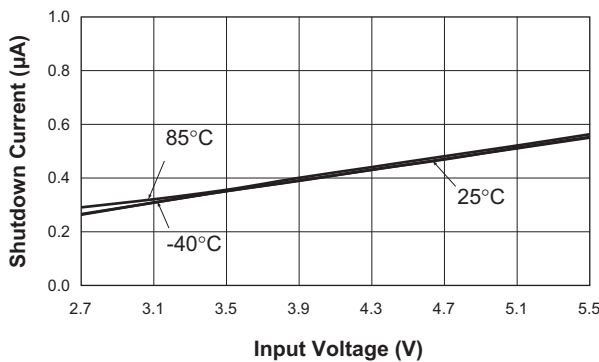

Feedback Voltage vs. Temperature
($R_{BALLAST} = 30.1\Omega$)

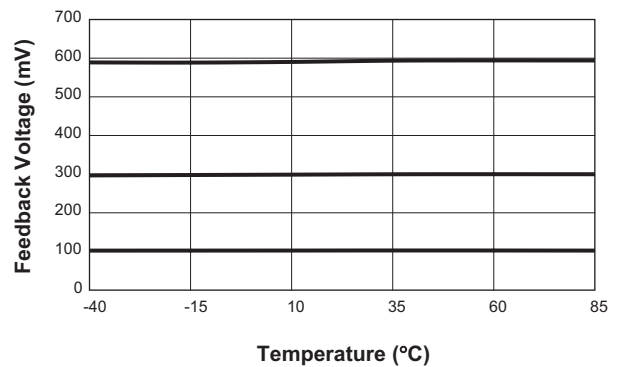

Typical Characteristics

Accuracy I_{LED} vs. Temperature

($V_{FB} = 0.6V$; $R_{BALLAST} = 30.1\Omega$)

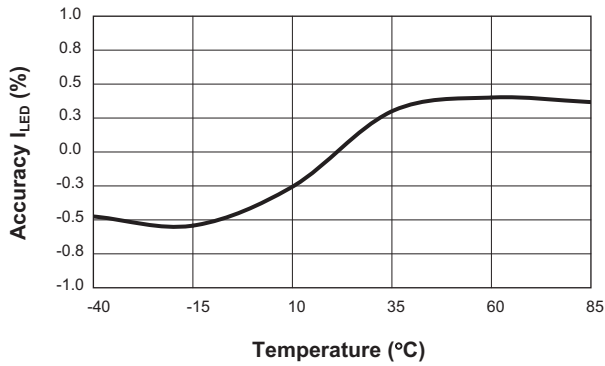

Accuracy I_{LED} vs. Input Voltage

($V_{FB} = 0.6V$; $R_{BALLAST} = 30.1\Omega$)

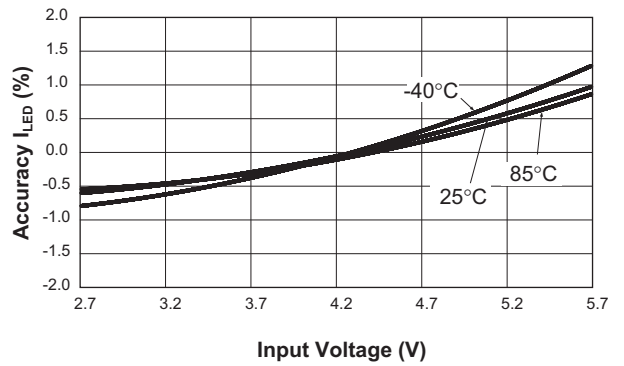

Line Transient
(6 White LEDs; $R_{BALLAST} = 30.1\Omega$)

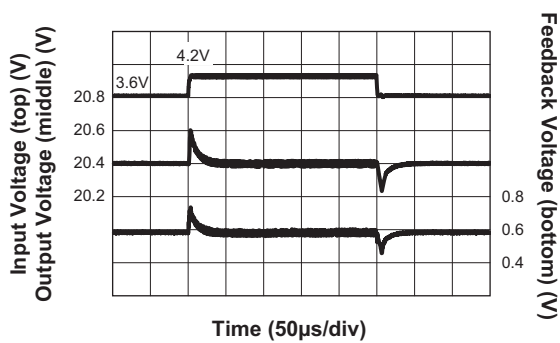

Shutdown
($V_{FB} = 0.6V$; $I_{LED} = 20mA$)

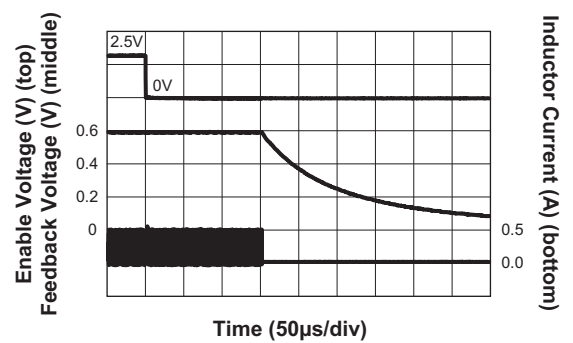

Output Ripple
(6 White LEDs; $I_{LED} = 13mA$)

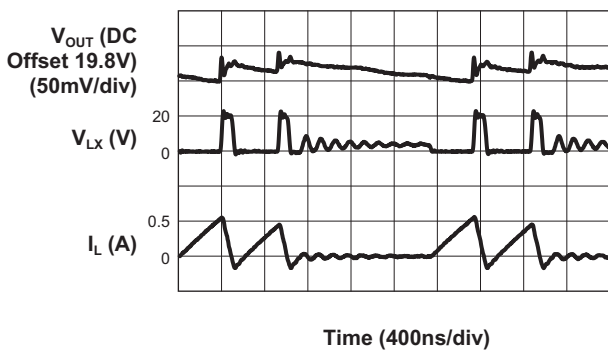

Output Ripple
(6 White LEDs; $I_{LED} = 20mA$)

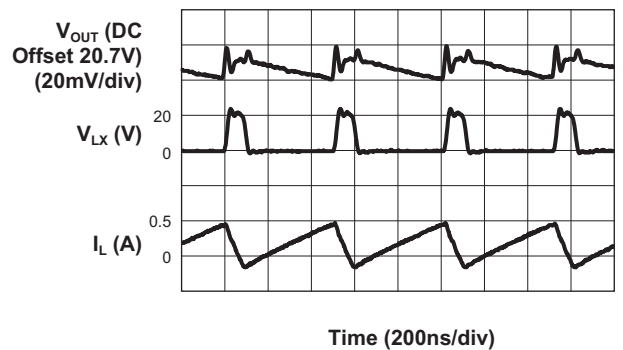

Typical Characteristics

AAT1231 Soft Start with S²Cwire
(6 White LEDs; $V_{FB} = 0.6V$)

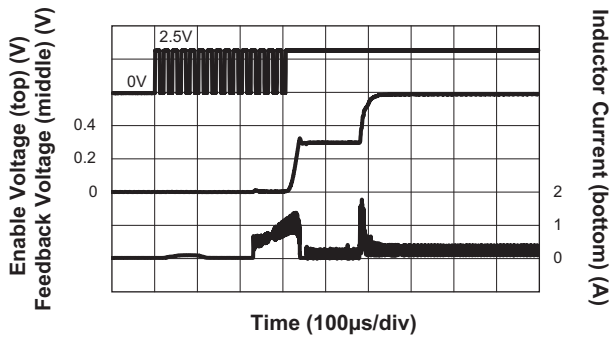

AAT1231 Soft Start
(6 White LEDs; $V_{FB} = 0.3V$)

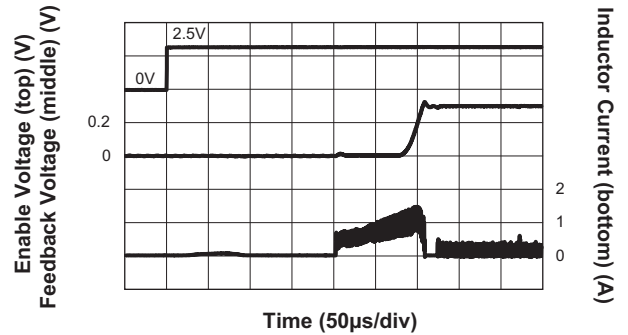

AAT1231-1 Soft Start with S²Cwire
(6 White LEDs; $V_{FB} = 0.3V$)

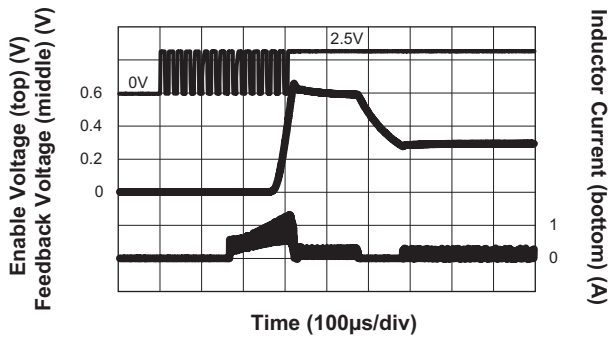

AAT1231-1 Soft Start
(6 White LEDs; $V_{FB} = 0.6V$)

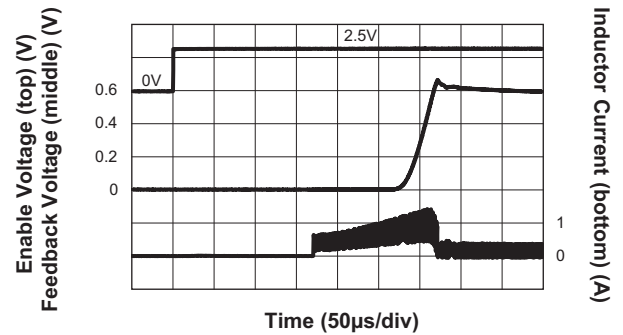

Transition of LED Current
(6 White LEDs; SEL = Low; $I_{LED} = 13.3mA$ to 6.6mA)

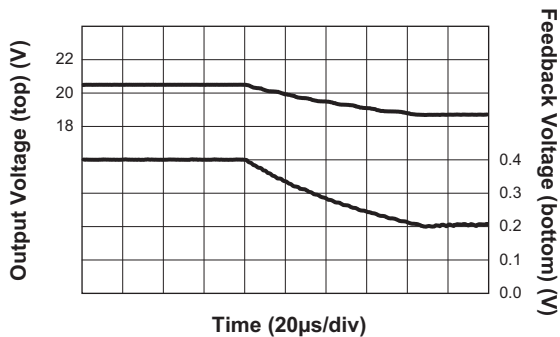

Transition of LED Current
(6 White LEDs; SEL = Low; $I_{LED} = 3.3mA$ to 13.3mA)

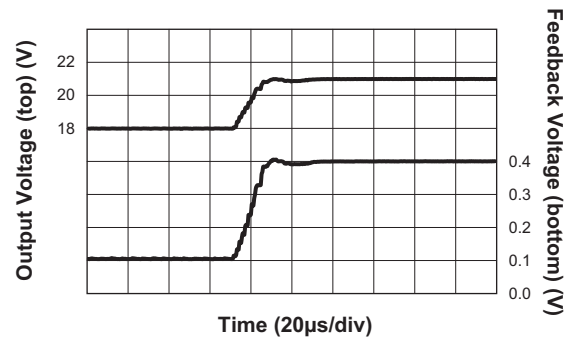

Typical Characteristics

EN/SET Latch Timeout vs. Input Voltage

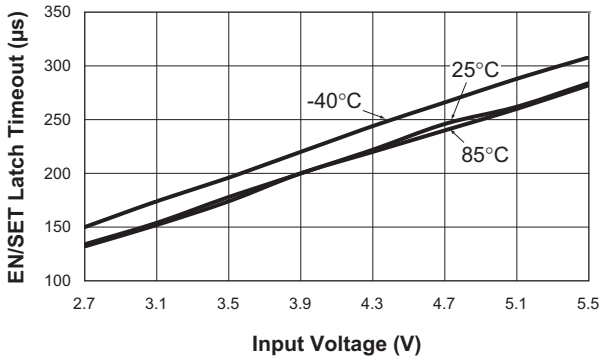

EN/SET Off Timeout vs. Input Voltage

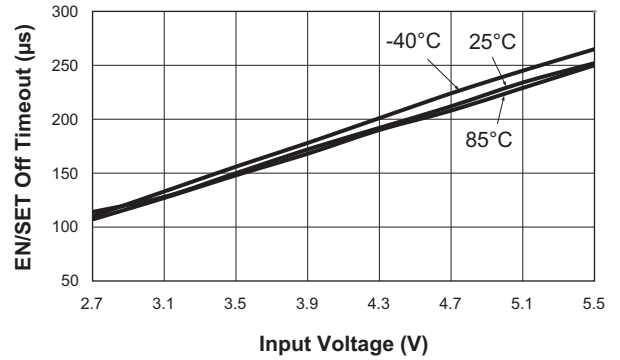

EN/SET Low Threshold vs. Input Voltage

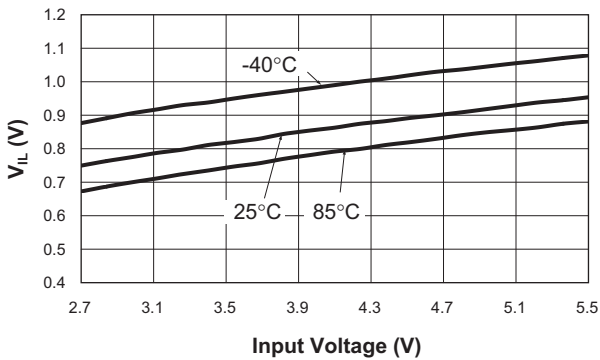

EN/SET High Threshold vs. Input Voltage

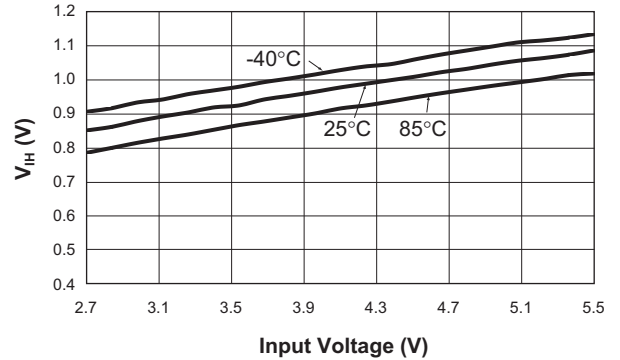

Low Side Switch On Resistance vs. Input Voltage

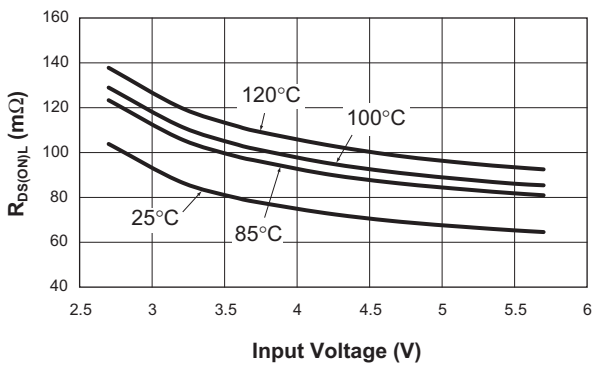

Input Disconnect Switch Resistance vs. Input Voltage

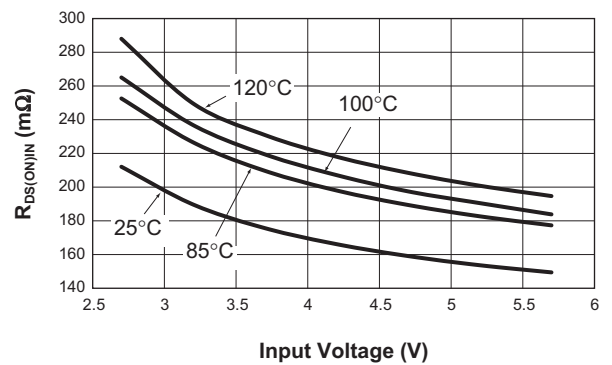

Functional Block Diagram

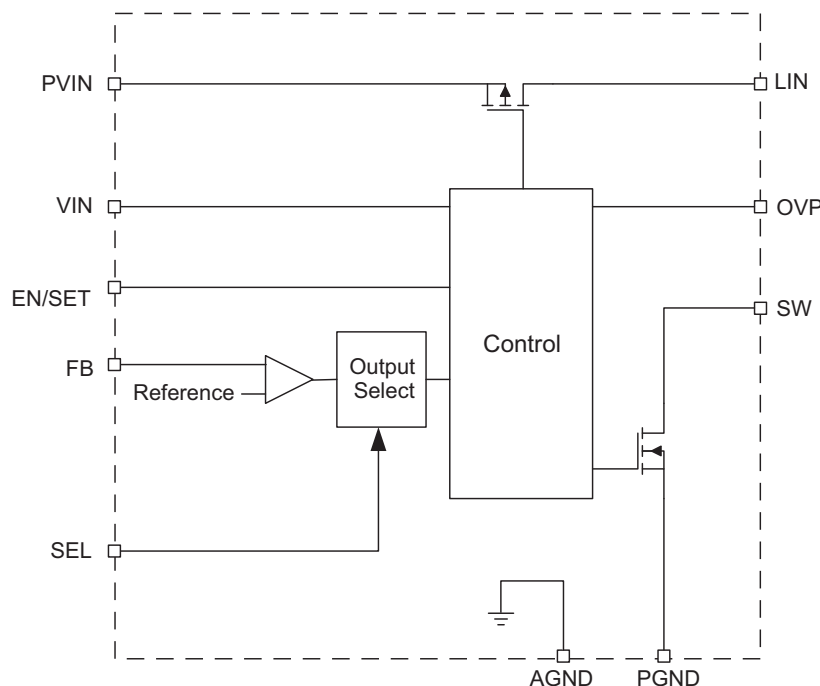

Functional Description

The AAT1231 and the AAT1231-1 consist of a DC/DC boost controller, an integrated slew rate controlled input disconnect MOSFET switch, and a high voltage MOSFET power switch. A high voltage rectifier, power inductor, output capacitor, and sense resistors are required to implement a DC/DC constant current boost converter. The input disconnect switch is activated when a valid input voltage is present and the EN/SET pin is pulled high. The slew rate control on the P-channel MOSFET ensures minimal inrush current as the output voltage is charged to the input voltage, prior to the switching of the N-channel power MOSFET. Monotonic turn-on is guaranteed by the integrated soft-start circuitry. Soft-start eliminates output voltage overshoot across the full input voltage range and all loading conditions.

The maximum current through the LED string is set by the ballast resistor and the feedback voltage of the IC. The output current may be programmed by adjusting

the level of the feedback reference voltage which is programmed through the S²Cwire interface. The SEL pin selects one of two feedback voltage ranges. For the AAT1231 and with a LOW logic level applied to the SEL pin, the FB pin voltage can be programmed from 0.1V to 0.4V. With a logic HIGH applied to the SEL pin, the FB pin voltage can be programmed from 0.3V to 0.6V. In the AAT1231-1, the SEL function is inverted in that the FB pin voltage can be programmed from 0.4V to 0.1V with a logic LOW applied to the SEL pin and 0.6V to 0.3V with a logic HIGH applied to the SEL pin. Regardless of which device is chosen, the feedback voltage can be set to any one of 16 current levels within each FB range, providing high-resolution control of the LED current, using the single-wire S²Cwire control.

For torch and flash applications where a short duration, pulsed load is desired, applying a low-to-high transition on the AAT1231's SEL pin produces a 1.5x to 3.0x LED current step. In the AAT1231-1 on the other hand, the LED current step for a low-to-high transition on the SEL

pin can be programmed from 3.0x to 1.5x. In both products, the step size is determined by the programmed voltage at the FB pin where the internal default setting is 3.0x in the AAT1231 and 1.5x in the AAT1231-1.

Control Loop

The AAT1231/1231-1 provide the benefits of current mode control with a simple hysteretic output current loop providing exceptional stability and fast response with minimal design effort. The device maintains exceptional constant current regulation, transient response, and cycle-by-cycle current limit without additional compensation components.

The AAT1231/1231-1 modulate the power MOSFET switching current to maintain the programmed FB voltage. This allows the FB voltage loop to directly program the required inductor current in order to maintain the desired LED current.

The switching cycle initiates when the N-channel MOSFET is turned ON and current ramps up in the inductor. The ON interval is terminated when the inductor current reaches the programmed peak current level. During the OFF interval, the input current decays until the lower threshold, or zero inductor current, is reached. The lower current is equal to the peak current minus a preset hysteresis threshold, which determines the inductor ripple current. The peak current is adjusted by the controller until the LED output current requirement is met.

The magnitude of the feedback error signal determines the average input current. Therefore, the AAT1231/1231-1 controller implements a programmed current source connected to the output capacitor, parallel with the LED string and ballast resistor. There is no right-half plane zero, and loop stability is achieved with no additional compensation components.

An increase in the feedback voltage (V_{FB}) results in an increased error signal sensed across the ballast resistor (R1). The controller responds by increasing the peak inductor current, resulting in higher average current in the inductor and LED string(s). Alternatively, when the V_{FB} is reduced, the controller responds by decreasing the peak inductor current, resulting in lower average current in the inductor and LED string(s).

Under light load conditions, the inductor OFF interval current goes below zero and the boost converter enters discontinuous mode operation. Further reduction in the load current results in a corresponding reduction in the switching frequency. The AAT1231/1231-1 provide pulsed frequency operation which reduces switching losses and maintains high efficiency under light load conditions.

Operating frequency varies with changes in the input voltage, output voltage, and inductor size. Once the boost converter has reached continuous mode, further increases in the LED current will not significantly change the operating frequency. A small 2.2 μ H ($\pm 20\%$) inductor is selected to maintain high frequency switching (up to 2MHz) and high efficiency operation for outputs up to 24V.

Soft Start / Enable

The input disconnect switch is activated when a valid input voltage is present and the EN/SET pin is pulled high. The slew rate control on the P-channel MOSFET ensures minimal inrush current as the output voltage is charged to the input voltage, prior to switching of the N-channel power MOSFET. Monotonic turn-on is guaranteed by the built-in soft-start circuitry. Soft start eliminates output current overshoot across the full input voltage range and all loading conditions.

After the soft start sequence has terminated, the initial LED current is determined by the internal, default FB voltage across the external ballast resistor at the FB pin. Additionally, the AAT1231 and the AAT1231-1 have been designed to offer the system designer two choices for the default FB voltage based on the state of the SEL pin. Changing the LED current from its initial default setting is easy by using the S²Cwire single wire serial interface; the FB voltage can be increased (as in the AAT1231; see Table 2) or decreased (as in the AAT1231-1; see Table 3) relative to the default FB voltage.

Some applications may require the output to be active when a valid input voltage is present. In these cases, add a 10k Ω resistor between the VIN, VP, and EN/SET pins to avoid startup issues.

Current Limit and Over-Temperature Protection

The switching of the N-channel MOSFET terminates when a current limit of 2.5A (typical) is exceeded. This minimizes power dissipation and component stresses under overload and short-circuit conditions. Switching resumes when the current decays below the current limit.

Thermal protection disables the AAT1231/1231-1 when internal dissipation becomes excessive. Thermal protection disables both MOSFETs. The junction over-temperature threshold is 140°C with 15°C of temperature hysteresis. The output voltage automatically recovers when the over-temperature fault condition is removed.

Over-Voltage Protection

Over-voltage protection prevents damage to the AAT1231/1231-1 during open-circuit or high output voltage conditions. An over-voltage event is defined as a condition where the voltage on the OVP pin exceeds the Over-Voltage Threshold Limit ($V_{OVP} = 1.2V$ typical). When the voltage on the OVP pin has reached the threshold limit, the converter stops switching and the output voltage decays. Switching resumes when the voltage on the OVP pin drops below the lower hysteresis limit, maintaining an average output voltage between the upper and lower OVP thresholds multiplied by the resistor divider scaling factor.

Under-Voltage Lockout

Internal bias of all circuits is controlled via the VIN input. Under-voltage lockout (UVLO) guarantees sufficient V_{IN} bias and proper operation of all internal circuitry prior to soft start.

Application Information

Over-Voltage Protection

OVP Protection with Open Circuit Failure

The OVP protection circuit consists of a resistor network tied from the output voltage to the OVP pin (see Figure 1). To protect the device from open circuit failure, the resistor divider can be selected such that the over-voltage threshold occurs prior to the output reaching 24V ($V_{OUT(MAX)}$). The value of R3 should be selected from 10kΩ to 20kΩ to minimize losses without degrading noise immunity.

$$R_2 = R_3 \cdot \left(\frac{V_{OUT(MAX)}}{V_{OVP}} - 1 \right)$$

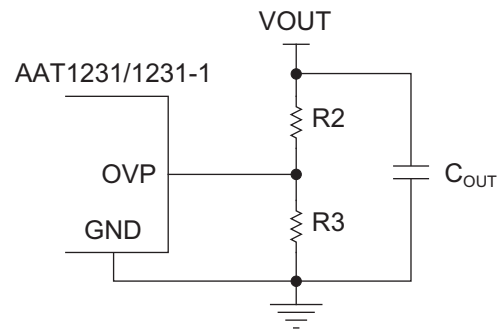

Figure 1: Over-Voltage Protection Circuit.

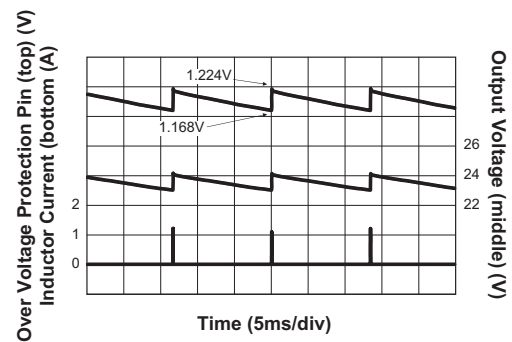

Figure 2: Over-Voltage Protection Open Circuit Response (No LED).

Assume $R_3 = 12k\Omega$ and $V_{OUT(MAX)} = 24V$. Selecting 1% resistor for high accuracy, this results in $R_2 = 226k\Omega$ (rounded to the nearest standard value). The minimum OVP threshold can be calculated:

$$V_{OUT(OVP_MIN)} = V_{OVP(MIN)} \cdot \left(\frac{R_2}{R_3} + 1 \right) = 21.8V$$

To avoid OVP detection and subsequent reduction in the programmed output current (see following section), the maximum operating voltage should not exceed the minimum OVP set point.

$$V_{OUT(MAX)} < V_{OUT(OVP_MIN)}$$

In some cases, this may disallow configurations with high LED forward voltage (V_{FLED}) and/or greater than five series white LEDs. V_{FLED} unit-to-unit tolerance can be as high as +15% of nominal for white LED devices.

OVP Constant Voltage Operation

Under closed loop constant current conditions, the output voltage is determined by the operating current, LED forward voltage characteristics (V_{FLED}), quantity of series connected LEDs (N), and the feedback pin voltage (V_{FB}).

$$V_{OUT} = V_{FB} + N \cdot V_{FLED}$$

When the rising OVP threshold is exceeded, switching is stopped and the output voltage decays. Switching automatically restarts when the output drops below the lower OVP hysteresis voltage (100mV typical) and, as a result, the output voltage increases. The cycle repeats, maintaining an average DC output voltage proportional to the average of the rising and falling OVP levels (multiplied by the resistor divider scaling factor). High operating frequency and small output voltage ripple ensure DC current and negligible flicker in the LED string(s).

The waveform in Figure 3 shows the output voltage and LED current at cold temperature with a six series white LED string and $V_{OVP} = 19.4V$. As shown, the output voltage rises as a result of the increased V_{FLED} which triggers the OVP constant voltage operation. Self heating of the LEDs triggers a smooth transition back to constant current control.

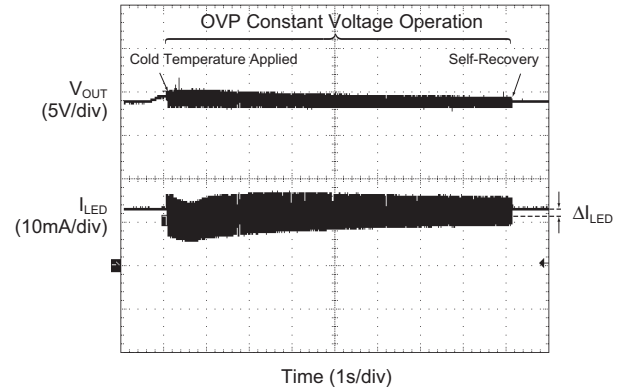

Figure 3: Over-Voltage Protection Constant Voltage Operation (6 White LEDs; $I_{LED} = 13mA$; $R_2 = 182k\Omega$; $R_3 = 12k\Omega$).

While OVP is active, the maximum LED current programming error (ΔI_{LED}) is proportional to voltage error across an individual LED (ΔV_{FLED}).

$$\Delta V_{FLED} = \frac{(N \cdot V_{FLED(MAX)} - V_{OUT(OVP_MIN)} - V_{FB})}{N}$$

To minimize the ΔI_{LED} error, the minimum OVP voltage ($V_{OUT(OVP_MIN)}$) may be increased, yielding a corresponding increase in the maximum OVP voltage ($V_{OUT(OVP_MAX)}$). Measurements should confirm that the maximum switching node voltage ($V_{SW(MAX)}$) is less than 28V under worst-case operating conditions.

$$V_{SW(MAX)} = V_{OVP(MAX)} \cdot \left(\frac{R_3}{R_2} + 1 \right) + V_F + V_{RING}$$

V_F = -Schottky Diode DS1 forward voltage at turn-OFF
 V_{RING} = Voltage ring occurring at turn-OFF

LED Selection and Current Setting

The AAT1231/1231-1 are well suited for driving white LEDs with constant current. Applications include main and sub-LCD display backlighting, and color LEDs.

The LED current is controlled by the FB voltage and the ballast resistor. For maximum accuracy, a 1% tolerance resistor is recommended.

The ballast resistor (R_{BALLAST}) value can be calculated as follows:

$$R_{\text{BALLAST}} = \frac{V_{\text{FB(MAX)}}}{I_{\text{LED(MAX)}}}$$

where:

$$V_{\text{FB(MAX)}} = 0.4\text{V when SEL} = \text{Low}$$

$$V_{\text{FB(MAX)}} = 0.6\text{V when SEL} = \text{High}$$

i.e., for a maximum LED current of 20mA (SEL = High):

$$R_{\text{BALLAST}} = \frac{V_{\text{FB}}}{I_{\text{LED(MAX)}}} = \frac{0.6}{0.020} = 30\Omega \approx 30.1\Omega$$

Maximum I_{LED} Current (mA)	R_{BALLAST} (Ω)	
	SEL = High	SEL = Low
50	12.1	8.06
40	15.0	10.0
35	16.9	11.3
30	20.0	13.3
25	24.3	16.2
20	30.1	20.0
15	40.2	26.7
10	60.4	40.2
5	121.0	80.6

Table 1: Maximum LED Current and R_{BALLAST} Resistor Values (1% Resistor Tolerance).

Typical white LEDs are driven at maximum continuous currents of 15mA to 20mA. For maximum output, two parallel strings of six series LEDs are used. A total output current of 30mA or 40mA is required (15mA to 20mA in each string). The maximum quantity of series connected LEDs is determined by the minimum OVP voltage of the boost converter ($V_{\text{OUT(OVP_MIN)}}$), minus the maximum feedback voltage ($V_{\text{FB(MAX)}}$) divided by the maximum LED forward voltage ($V_{\text{FLED(MAX)}}$). $V_{\text{FLED(MAX)}}$ can be estimated from the manufacturers' datasheet at the maximum LED operating current.

$$V_{\text{OUT(OVP_MIN)}} = V_{\text{OVP(MIN)}} \cdot \left(\frac{R_2}{R_3} + 1 \right)$$

$$N = \frac{(V_{\text{OUT(OVP_MIN)}} - V_{\text{FB(MAX)}})}{V_{\text{FLED(MAX)}}}$$

Figure 4 shows the schematic of using six LEDs in series. Assume $V_{\text{FLED}} @ 20\text{mA} = 3.5\text{V}$ (typical) from LW M673 (OSRAM) datasheet.

$$V_{\text{OUT(OVP_MIN)}} = 1.1\text{V} \cdot \left(\frac{226\text{k}\Omega}{12\text{k}\Omega} + 1 \right) = 21.82\text{V}$$

$$N = \frac{21.82\text{V} - 0.6\text{V}}{3.5\text{V}}$$

$$\approx 6.1$$

Therefore, under typical operating conditions, six LEDs can be used in series.

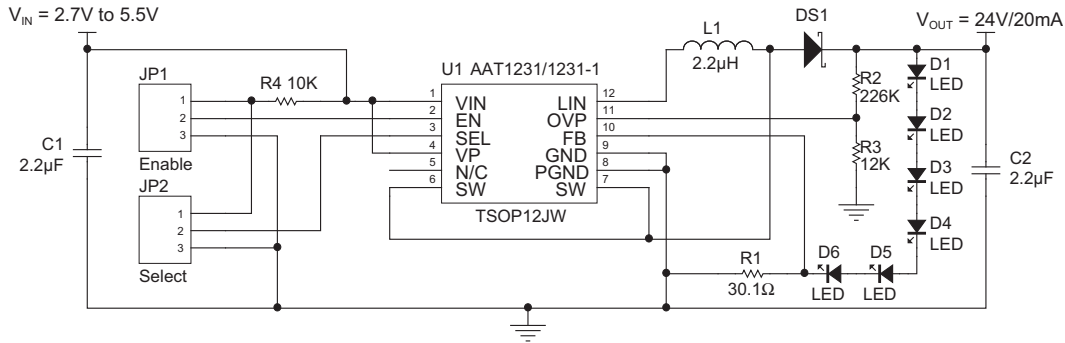

- U1 AAT1231/1231-1 TSOPJW-12
- L1 2.2µH SD3814-2R2
- C1 2.2µF 10V 0603
- C2 2.2µF 25V 0805
- D1-D6 LW M673 White LED
- DS1 30V 0.2A BAT42W SOD-123
- R1 30.1 0603
- R2 226K 0603
- R3 12K 0603
- R4 10K 0603

Figure 4: AAT1231/1231-1 White LED Boost Converter Schematic.

LED Brightness Control

The AAT1231 and the AAT1231-1 use S²Cwire programming to control LED brightness and does not require PWM (pulse width modulation) or additional control circuitry. This feature greatly reduces the burden on a microcontroller or system IC to manage LED or display brightness, allowing the user to “set it and forget it.” With its high-speed serial interface (1MHz data rate), the output current of the AAT1231 and the AAT1231-1 can be changed successively to brighten or dim the LEDs in smooth transitions (i.e., to fade out) or in abrupt steps, giving the user complete programmability and real-time control of LED brightness.

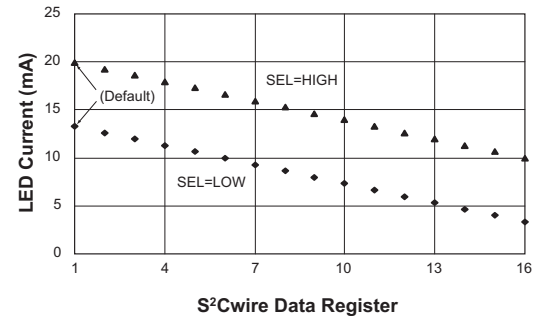

Figure 6: Programming AAT1231-1 LED Current with R_{BALLAST} = 30.1Ω.

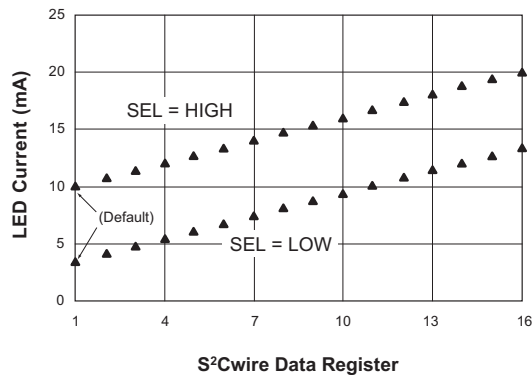

Figure 5: Programming AAT1231 LED Current with R_{BALLAST} = 30.1Ω.

Alternatively, toggling the SEL logic pin from low to high implements stepped or pulsed LED currents by increasing the FB pin voltage. Figures 7 and 8 illustrate the SELECT pin scaling factor, defined as the LED current with SEL=HIGH divided by the LED current with SEL=LOW. For the AAT1231, scaling factors from 1.5x to 3.0x are possible, depending on the S²Cwire data register (default = 3.0x). In the AAT1231-1, the possible scaling factors are 3.0x to 1.5x with the internal default setting of 1.5x.

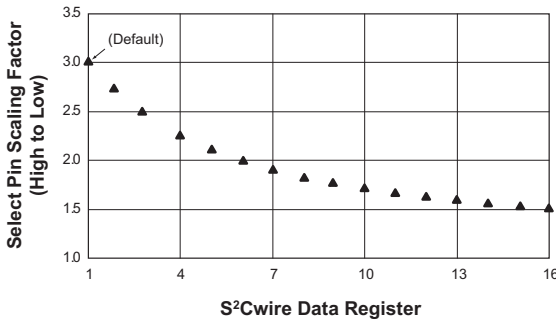

Figure 7: AAT1231 SEL Pin Scaling Factor: $I_{LED} (SEL = High)$ Divided by $I_{LED} (SEL = Low)$.

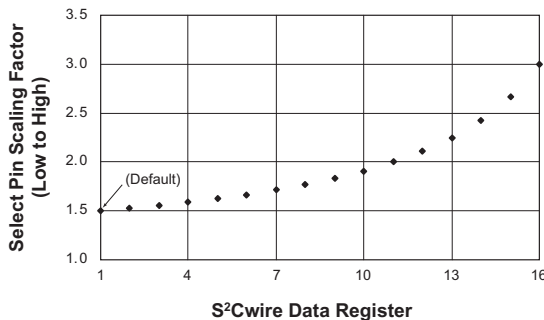

Figure 8: AAT1231-1 SEL Pin Scaling Factor: $I_{LED} (SEL = High)$ Divided by $I_{LED} (SEL = Low)$.

S²Cwire Serial Interface

AnalogicTech’s S²Cwire single wire serial interface is a proprietary high-speed single-wire interface available only from AnalogicTech. The S²Cwire interface records rising edges of the EN/SET input and decodes them into

16 individual states. Each state corresponds to a reference feedback voltage setting on the FB pin, as shown in Table 2.

S²Cwire Serial Interface Timing

The S²Cwire single wire serial interface data can be clocked-in at speeds up to 1MHz. After data has been submitted, EN/SET is held high to latch the data for a period T_{LAT} . The FB pin voltage is subsequently changed to the level as defined by the state of the SEL logic pin. When EN/SET is set low for a time greater than T_{OFF} , the AAT1231/1231-1 is disabled. When either the AAT1231 or the AAT1231-1 is disabled, the register is reset to its default value. In the AAT1231, the default register value sets the FB pin voltage to 0.6V if the EN/SET pin is subsequently pulled HIGH. In the AAT1231-1, the FB pin voltage is set to 0.3V under the same condition.

S²Cwire Feedback Voltage Programming

The FB pin voltage is set to the default level at initial powerup. The AAT1231 and the AAT1231-1 are programmed through the S²Cwire interface. Table 2 illustrates FB pin voltage programming for the AAT1231 and Table 3 illustrates FB pin voltage programming for the AAT1231-1. The rising clock edges applied at the EN/SET pin determine the FB pin voltage. If a logic LOW is applied at the SEL pin, the default feedback voltage range for the AAT1231 is 0.1V to 0.4V; for a logic HIGH condition at the SEL pin, the default feedback voltage range is 0.3V to 0.6V. Conversely, if a logic LOW is applied at the SEL pin of the AAT1231-1, the default feedback voltage range becomes 0.4V to 0.1V and 0.6V to 0.3V for a logic HIGH condition at the SEL pin.

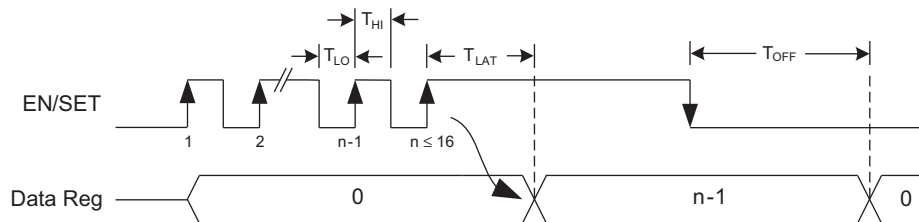

Figure 9: AAT1231/1231-1 S²Cwire Timing Diagram to Program the Output Voltage.

Rising Clock Edges/Data Register	SEL = Low		SEL = High	
	Reference Voltage (V)	LED Current (mA); $R_{BALLAST} = 30.1\Omega$	Reference Voltage (V)	LED Current (mA); $R_{BALLAST} = 30.1\Omega$
1	0.1 (default)	3.32	0.3 (default)	9.97
2	0.12	3.99	0.32	10.63
3	0.14	4.65	0.34	11.30
4	0.16	5.32	0.36	11.96
5	0.18	5.98	0.38	12.62
6	0.20	6.64	0.40	13.29
7	0.22	7.31	0.42	13.95
8	0.24	7.97	0.44	14.62
9	0.26	8.64	0.46	15.28
10	0.28	9.30	0.48	15.95
11	0.30	9.97	0.50	16.61
12	0.32	10.63	0.52	17.28
13	0.34	11.30	0.54	17.94
14	0.36	11.96	0.56	18.60
15	0.38	12.62	0.58	19.27
16	0.40	13.29	0.60	19.93

Table 2: AAT1231 S²Cwire Reference Feedback Voltage Control Settings with $R_{BALLAST} = 30.1\Omega$ (Assume Nominal Values).

Rising Clock Edges/Data Register	SEL = Low		SEL = High	
	Reference Voltage (V)	LED Current (mA); $R_{BALLAST} = 30.1\Omega$	Reference Voltage (V)	LED Current (mA); $R_{BALLAST} = 30.1\Omega$
1	0.4 (default)	13.29	0.6 (default)	19.93
2	0.38	12.62	0.58	19.27
3	0.36	11.96	0.56	18.60
4	0.34	11.30	0.54	17.94
5	0.32	10.63	0.52	17.28
6	0.30	9.97	0.50	16.61
7	0.28	9.30	0.48	15.95
8	0.26	8.64	0.46	15.28
9	0.24	7.97	0.44	14.62
10	0.22	7.31	0.42	13.95
11	0.20	6.64	0.40	13.29
12	0.18	5.98	0.38	12.62
13	0.16	5.32	0.36	11.96
14	0.14	4.65	0.34	11.30
15	0.12	3.99	0.32	10.63
16	0.10	3.32	0.30	9.97

Table 3: AAT1231-1 S²Cwire Reference Feedback Voltage Control Settings With $R_{BALLAST} = 30.1\Omega$ (Assumes Nominal Values).

Selecting the Schottky Diode

To ensure minimum forward voltage drop and no recovery, high voltage Schottky diodes are considered the best choice for the AAT1231/1231-1 boost converters. The output diode is sized to maintain acceptable efficiency and reasonable operating junction temperature under full load operating conditions. Forward voltage (V_F) and package thermal resistance (θ_{JA}) are the dominant factors to consider in selecting a diode. The diode non-repetitive peak forward surge current rating (I_{FSM}) should be considered for high pulsed load applications, such as camera flash. I_{FSM} rating drops with increasing conduction period. Manufacturers' datasheets should be consulted to verify reliability under peak loading conditions. The diode's published current rating may not reflect actual operating conditions and should be used only as a comparative measure between similarly rated devices.

20V rated Schottky diodes are recommended for outputs less than 15V, while 30V rated Schottky diodes are recommended for outputs greater than 15V.

The switching period is divided between ON and OFF time intervals.

$$\frac{1}{F_S} = T_{ON} + T_{OFF}$$

During the ON time, the N-channel power MOSFET is conducting and storing energy in the boost inductor. During the OFF time, the N-channel power MOSFET is not conducting. Stored energy is transferred from the input battery and boost inductor to the output load through the output diode.

Duty cycle is defined as the ON time divided by the total switching interval.

$$D = \frac{T_{ON}}{T_{ON} + T_{OFF}}$$

$$= T_{ON} \cdot F_S$$

The maximum duty cycle can be estimated from the relationship for a continuous mode boost converter. Maximum duty cycle (D_{MAX}) is the duty cycle at minimum input voltage ($V_{IN(MIN)}$).

$$D_{MAX} = \frac{V_{OUT} - V_{IN(MIN)}}{V_{OUT}}$$

The average diode current during the OFF time can be estimated.

$$I_{AVG(OFF)} = \frac{I_{OUT}}{1 - D_{MAX}}$$

The following curves show the V_F characteristics for different Schottky diodes (100°C case). The V_F of the Schottky diode can be estimated from the average current during the off time.

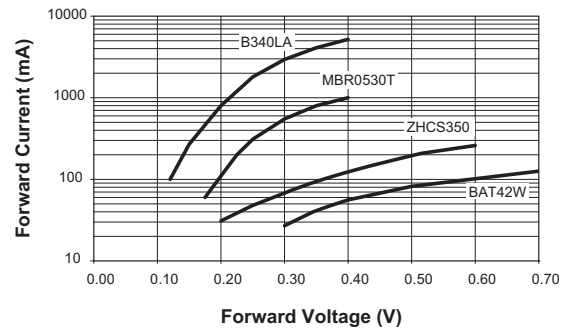

The average diode current is equal to the output current.

$$I_{AVG(TOT)} = I_{OUT}$$

The average output current multiplied by the forward diode voltage determines the loss of the output diode.

$$P_{LOSS(DIODE)} = I_{AVG(TOT)} \cdot V_F$$

$$= I_{OUT} \cdot V_F$$

For continuous LED currents, the diode junction temperature can be estimated.

$$T_{J(DIODE)} = T_{AMB} + \theta_{JA} \cdot P_{LOSS(DIODE)}$$

Manufacturer	Part Number	Rated Forward Current (A)	Non-Repetitive Peak Surge Current (A)	Rated Voltage (V)	Thermal Resistance (θ_{JA} , °C/W)	Case
Diodes, Inc.	B340LA	3	70.0	40	25	SMA
Diodes, Inc.	BAT42W	0.2	4.0	30	500	SOD-123
ON Semi	MBR0530T	0.5	5.5	30	206	SOD-123
Zetex	ZHCS350	0.35	4.2	40	330	SOD-523
Central Semi	CMDSH2-3	0.2	1.0	30	500	SOD-323

Table 4: Typical Surface Mount Schottky Rectifiers for Various Output Levels.

Output diode junction temperature should be maintained below 110°C, but may vary depending on application and/or system guidelines. The diode θ_{JA} can be minimized with additional PCB area on the cathode. PCB heat-sinking the anode may degrade EMI performance. The reverse leakage current of the rectifier must be considered to maintain low quiescent (input) current and high efficiency under light load. The rectifier reverse current increases dramatically at elevated temperatures.

Selecting the Boost Inductor

The AAT1231 and the AAT1231-1 controllers utilize hysteretic control and the switching frequency varies with output load and input voltage. The value of the inductor determines the maximum switching frequency of the boost converter. Increased output inductance decreases the switching frequency, resulting in higher peak currents and increased output voltage ripple. To maintain 2MHz maximum switching frequency and stable operation, an output inductor sized from 1.5µH to 2.7µH is recommended.

A better estimate of D_{MAX} is possible once V_F is known.

$$D_{MAX} = \frac{(V_{OUT} + V_F - V_{IN(MIN)})}{(V_{OUT} + V_F)}$$

Where V_F is the Schottky diode forward voltage. If not known, it can be estimated at 0.5V.

Manufacturer’s specifications list both the inductor DC current rating, which is a thermal limitation, and peak inductor current rating, which is determined by the saturation characteristics. Measurements at full load and high ambient temperature should be completed to ensure that the inductor does not saturate or exhibit excessive temperature rise.

The output inductor (L) is selected to avoid saturation at minimum input voltage, maximum output load conditions. Peak current may be estimated using the following equation, assuming continuous conduction mode. Worst-case peak current occurs at minimum input voltage (maximum duty cycle) and maximum load. Switching frequency (F_S) can be estimated from the curves and assumes a 2.2µH inductor.

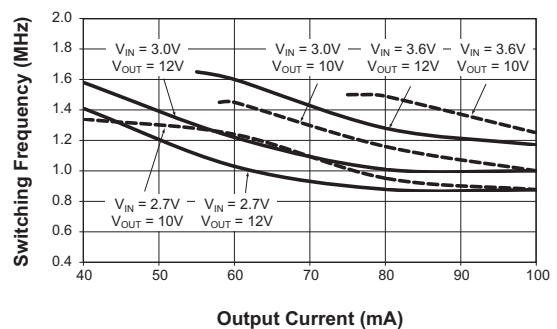
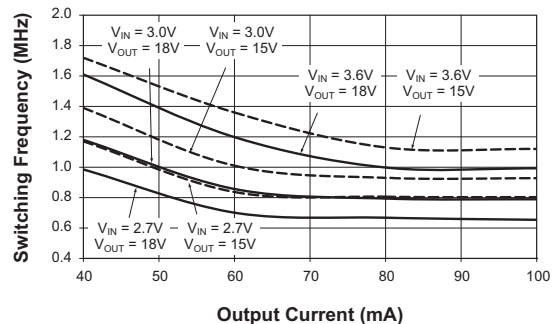

$$I_{PEAK} = \frac{I_{OUT}}{(1 - D_{MAX})} + \frac{D_{MAX} \cdot V_{IN(MIN)}}{(2 \cdot F_S \cdot L)}$$

At light load and low output voltage, the controller reduces the operating frequency to maintain maximum operating efficiency. As a result, further reduction in output load does not reduce the peak current. Minimum peak current can be estimated from 0.5A to 0.75A.

At high load and high output voltages, the switching frequency is somewhat diminished, resulting in higher I_{PEAK} . Bench measurements are recommended to confirm actual I_{PEAK} and ensure that the inductor does not saturate at maximum LED current and minimum input voltage.

The RMS current flowing through the boost inductor is equal to the DC plus AC ripple components. Under worst-case RMS conditions, the current waveform is critically continuous. The resulting RMS calculation yields worst-case inductor loss. The RMS current value should be compared against the manufacturer’s temperature rise, or thermal derating, guidelines.

$$I_{RMS} = \frac{I_{PEAK}}{\sqrt{3}}$$

For a given inductor type, smaller inductor size leads to an increase in DCR winding resistance and, in most cases, increased thermal impedance. Winding resistance degrades boost converter efficiency and increases the inductor’s operating temperature.

$$P_{LOSS(INDUCTOR)} = I_{RMS}^2 \cdot DCR$$

To ensure high reliability, the inductor case temperature should not exceed 100°C. In some cases, PCB heatsink-

ing applied to the LIN node (non-switching) can improve the inductor’s thermal capability. PCB heatsinking may degrade EMI performance when applied to the SW node (switching) of the AAT1231/1231-1.

Shielded inductors provide decreased EMI and may be required in noise sensitive applications. Unshielded chip inductors provide significant space savings at a reduced cost compared to shielded (wound and gapped) inductors. In general, chip-type inductors have increased winding resistance (DCR) when compared to shielded, wound varieties.

Inductor Efficiency Considerations

The efficiency for different inductors is shown in Figure 7 for six white LEDs in series. Smaller inductors yield increased DCR and reduced operating efficiency.

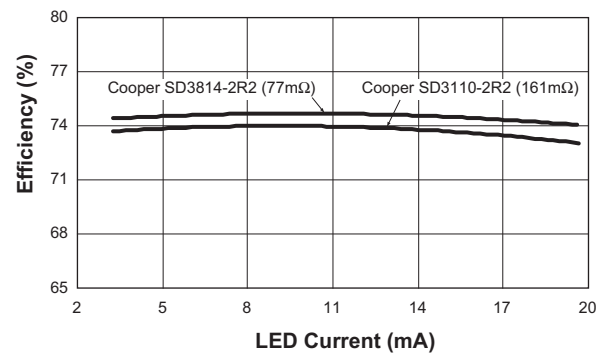

Figure 10: AAT1231/1231-1 Efficiency for Different Inductor Types ($V_{IN} = 3.6V$; Six White LEDs in Series).

Manufacturer	Part Number	Inductance (μH)	Maximum DC I_{SAT} Current (mA)	DCR (mΩ)	Size (mm) LxWxH	Type
Sumida www.sumida.com	CDRH2D11-2R2	2.2	780	78	3.2x3.2x1.2	Shielded
Cooper Electronics www.cooperet.com	SD3814-2R2	2.2	1900	77	4.0x4.0x1.4	Shielded
	SD3110-2R2	2.2	910	161	3.1x3.1x1.0	Shielded
Murata www.murata.com	LQH3NPN2R2NG0	2.2	1250	164	3.0x3.0x1.0	Chip Coil Shield
	LQM2HPN2R2MG0	2.2	1300	80	2.5x2.0x1.0	Chip Coil Shield
Taiyo Yuden www.t-yuden.com	NR3010T-2R2M	2.2	1100	95	3.0x3.0x1.0	Shielded
	CBC2016T2R2M	2.2	750	200	2.0x1.6x1.6	Chip Non-Shielded
	CBC2518T2R2M	2.2	510	90	2.5x1.8x1.8	Shielded

Table 5: Recommended Inductors for Various Output Levels (Select $I_{PEAK} < I_{SAT}$).

Selecting the Boost Capacitors

The high output ripple inherent in the boost converter necessitates low impedance output filtering.

Multi-layer ceramic (MLC) capacitors provide small size and adequate capacitance, low parasitic equivalent series resistance (ESR) and equivalent series inductance (ESL), and are well suited for use with the AAT1231/1231-1 boost regulator. MLC capacitors of type X7R or X5R are recommended to ensure good capacitance stability over the full operating temperature range.

The output capacitor is sized to maintain the output load without significant voltage droop (ΔV_{OUT}) during the power switch ON interval, when the output diode is not conducting. A ceramic output capacitor from 2.2 μ F to 4.7 μ F is recommended (see Table 5). Typically, 25V rated capacitors are required for the 24V maximum boost output. Ceramic capacitors sized as small as 0805 are available which meet these requirements.

MLC capacitors exhibit significant capacitance reduction with applied voltage. Output ripple measurements should confirm that output voltage droop and operating stability are acceptable. Voltage derating can minimize this factor, but results may vary with package size and among specific manufacturers.

Output capacitor size can be estimated at a switching frequency (F_S) of 500kHz (worst case).

$$C_{OUT} = \frac{I_{OUT} \cdot D_{MAX}}{F_S \cdot \Delta V_{OUT}}$$

To maintain stable operation at full load, the output capacitor should be sized to maintain ΔV_{OUT} between 100mV and 200mV.

The boost converter input current flows during both ON and OFF switching intervals. The input ripple current is less than the output ripple and, as a result, less input capacitance is required.

PCB Layout Guidelines

Boost converter performance can be adversely affected by poor layout. Possible impact includes high input and output voltage ripple, poor EMI performance, and reduced operating efficiency. Every attempt should be made to optimize the layout in order to minimize parasitic PCB effects (stray resistance, capacitance, and inductance) and EMI coupling from the high frequency SW node. A suggested PCB layout for the AAT1231/1231-1 boost converter is shown in Figures 10 and 11. The following PCB layout guidelines should be considered:

1. Minimize the distance from Capacitor C1 and C2 negative terminal to the PGND pins. This is especially true with output capacitor C2, which conducts high ripple current from the output diode back to the PGND pins.
2. Minimize the distance between L1 to DS1 and switching pin SW; minimize the size of the PCB area connected to the SW pin.
3. Maintain a ground plane and connect to the IC PGND pin(s) as well as the GND terminals of C1 and C2.
4. Consider additional PCB area on DS1 cathode to maximize heatsinking capability. This may be necessary when using a diode with a high V_F and/or thermal resistance.
5. To avoid problems at startup, add a 10k Ω resistor between the VIN, VP and EN/SET pins (R4). This is critical in applications requiring immunity from input noise during "hot plug" events, e.g. when plugged into an active USB port.

Manufacturer	Part Number	Value (µF)	Voltage Rating	Temp Co	Case Size
Murata	GRM188R60J225KE19	2.2	6.3	X5R	0603
Murata	GRM188R61A225KE34	2.2	10	X5R	0603
Murata	GRM219R61E225KA12	2.2	25	X5R	0805
Murata	GRM21BR71E225KA73L	2.2	25	X7R	0805
Murata	GRM21BR61E475KA12	4.7	25	X5R	0805

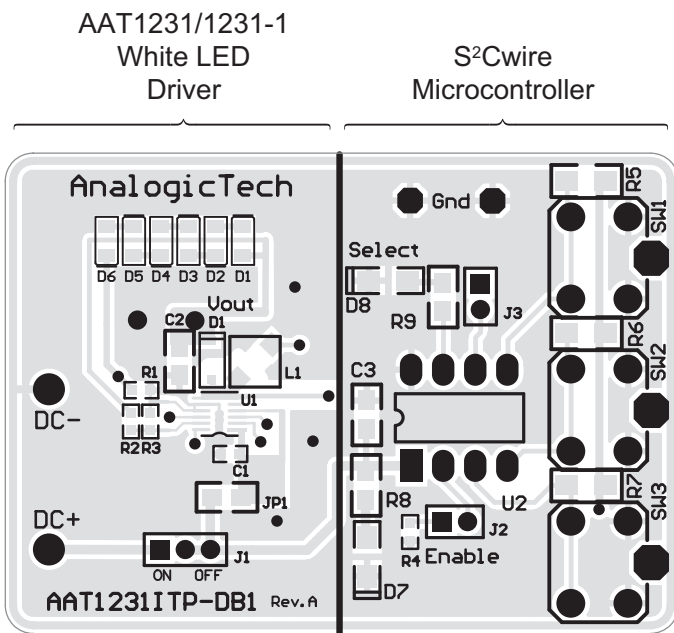
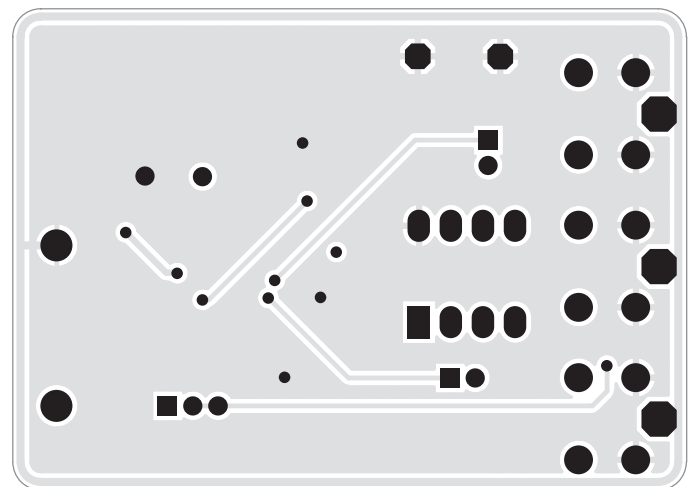
Table 6: Recommended Ceramic Capacitors.

Figure 11: AAT1231/1231-1 Evaluation Board Top Side Layout (with six LEDs and microcontroller).

Figure 12: AAT1231/1231-1 Evaluation Board Bottom Side Layout (with six LEDs and microcontroller).

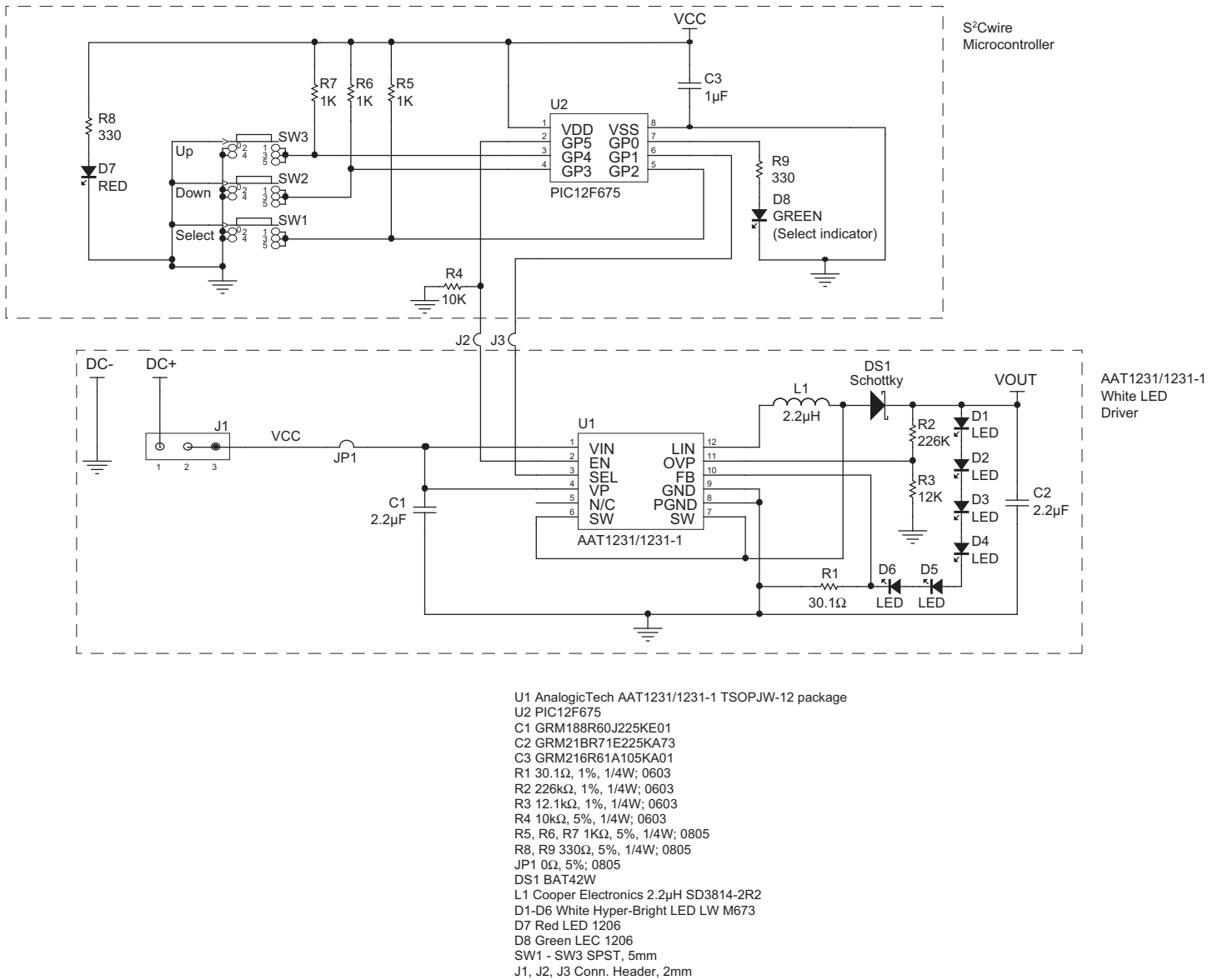

Figure 13: AAT1231/1231-1 Evaluation Board Schematic (with six LEDs and microcontroller).

Additional Applications

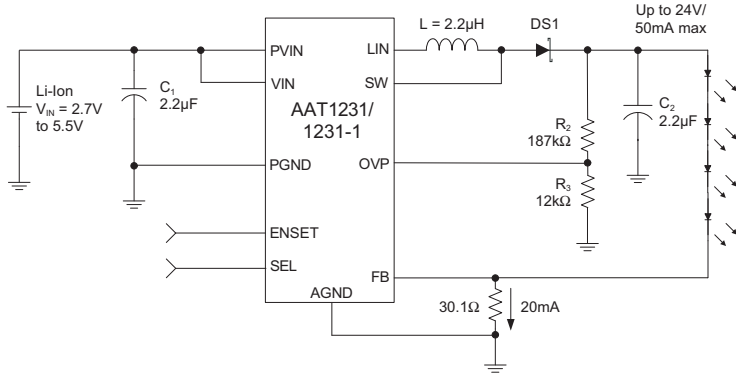

Figure 14: Four LEDs In Series Configuration.

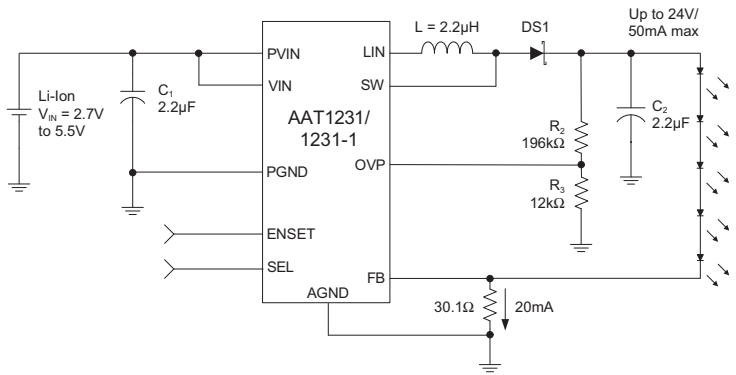
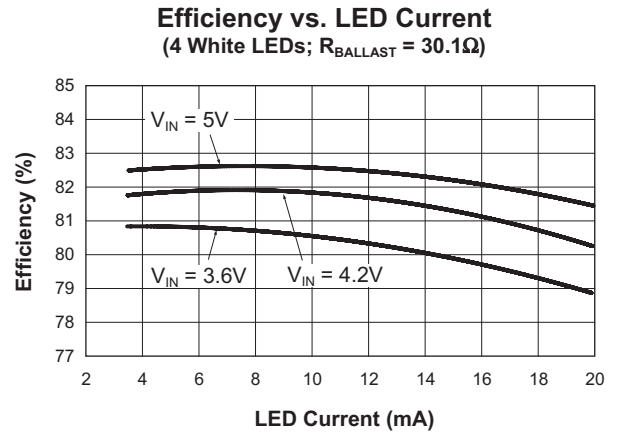
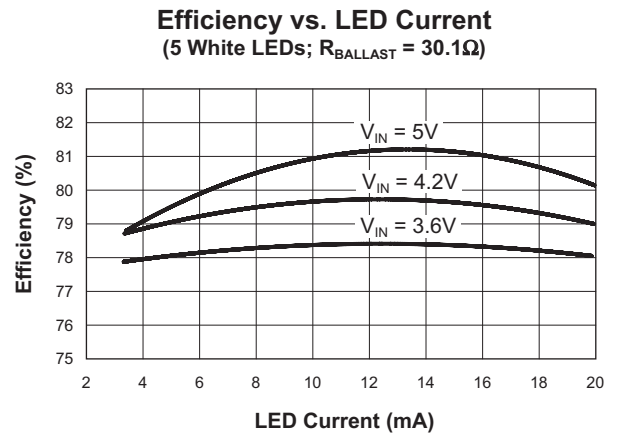

Figure 15: Five LEDs In Series Configuration.



Efficiency vs. LED Current
(6 White LEDs; $R_{\text{BALLAST}} = 30.1\Omega$)

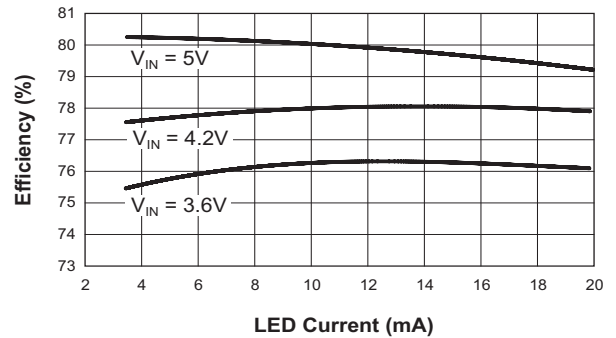

Figure 16: Six LEDs In Series Configuration.

Efficiency vs. LED Current
(12 White LEDs; $R_{\text{BALLAST}} = 30.1\Omega$)

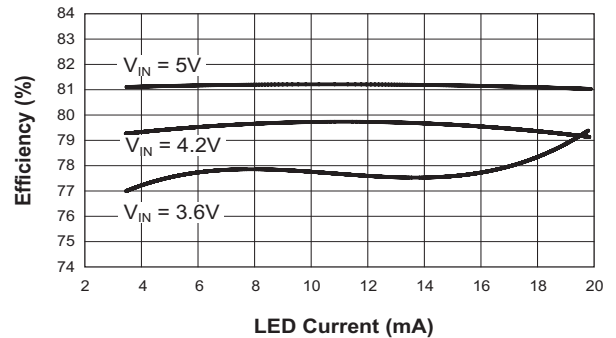
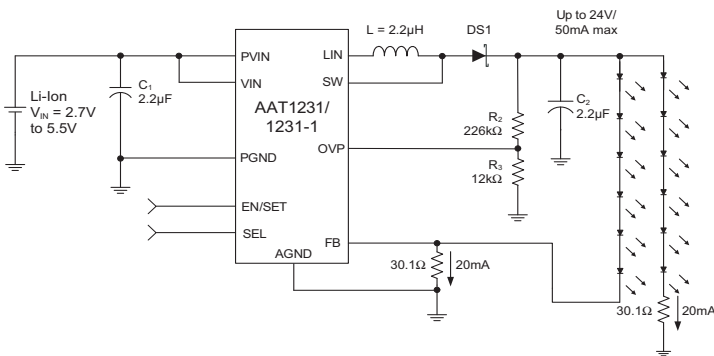
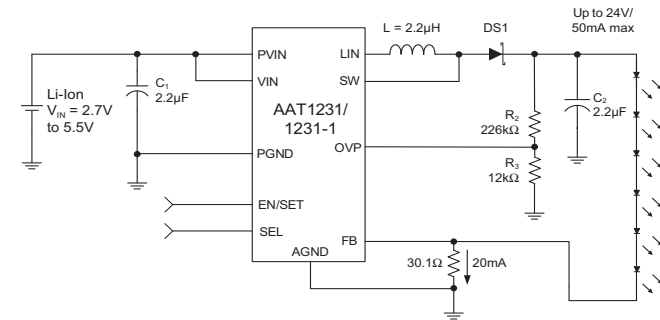

Figure 17: Twelve LEDs In Series/Parallel Configuration.



Multi-String White LED Configurations for Digital Photo Frame Applications

The AAT1231 and AAT1231-1 can be configured to light up as many as thirty-two white LEDs (WLED). This solution is scalable, flexible and good for digital photo frame applications with multi-strings of WLEDs.

The multi-string WLED configuration can be composed of many different parallel/series combinations, such as 6S2P, 6S3P, 5S4P, 5S5P, 5S6P, 4S7P, 4S8P, 3S9P, and 3S10P. 'S' is defined as the number of WLEDs in a series per string. 'P' is defined as the number of strings of WLEDs that are connected from the output voltage (V_{OUT}) to the ballast resistor, or in parallel. To match the "brightness" of each separate string of WLEDs, each string must have the same number of WLEDs in them. The over-voltage protection (OVP) should also be adjusted according to the maximum feedback voltage plus the maximum forward voltage (V_F) of each WLED multiplied by the total number of WLEDs in any of the parallel strings of WLEDs. The efficiency of one configuration

(3S7P: 3 in series per string with 7 strings in parallel) is shown in Figure 18. A scalable schematic and PCB layout are illustrated in Figures 19 through 21.

Efficiency vs. Total LED Current
(21 White LEDs [3 in Series, 7 in Parallel]; $R_{BALLAST} = 4.32\Omega$)

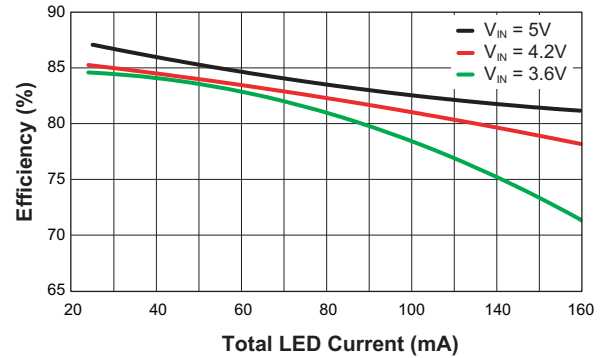
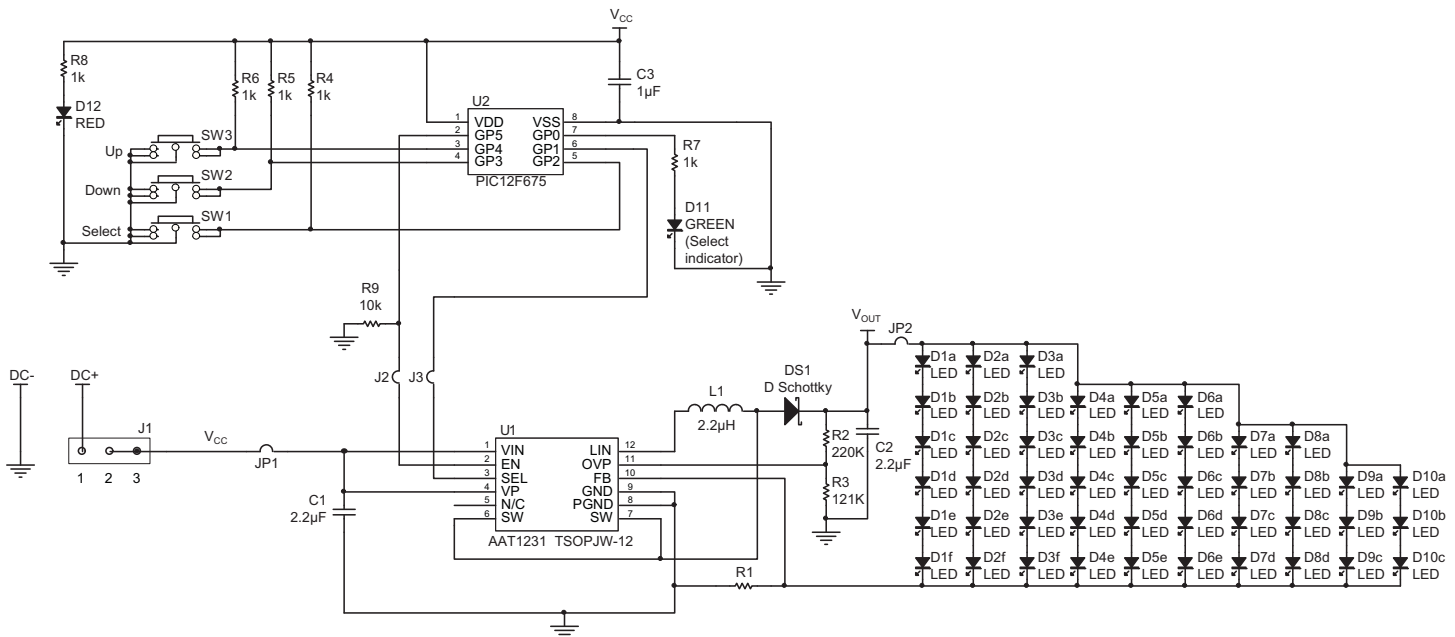

Figure 18: Efficiency of the 3S7P Multi-String Configuration.



- C1 10V 0603 X5R 2.2µF GRM188R60J225KE01
- C2 25V 0805 X7R 2.2µF GRM21BR71E225KA73
- DS1 B340LA
- L1 2.2µH SD10-2R2, SD12-2R2, SD18-2R2
- D1a-D10c White LED

Figure 19: Multi-String WLED Application Schematic.

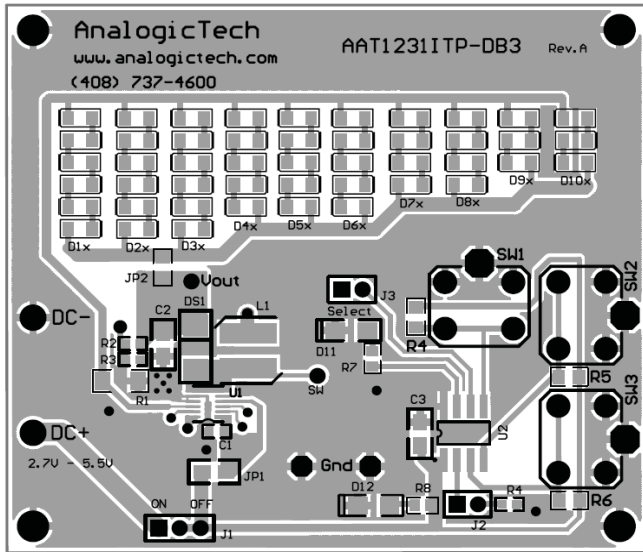

Figure 20: Top Layer of the Multi-String WLED Application.

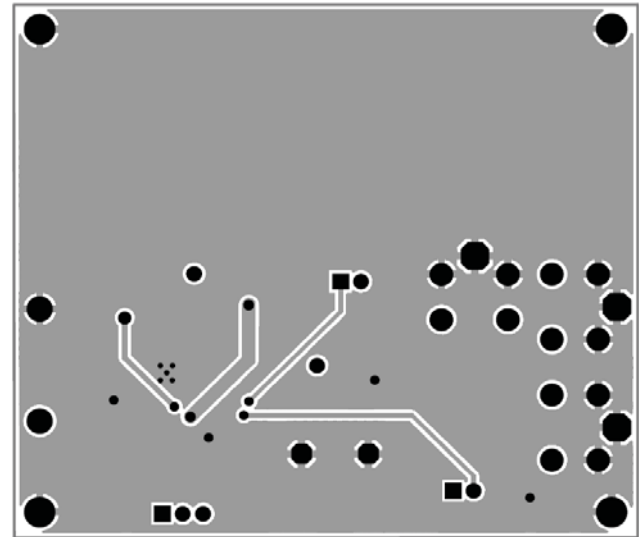

Figure 21: Bottom Layer of the Multi-String WLED Application.

The ballast resistor R1 is calculated based on the total number of WLED strings and the total WLED current required from the AAT1231 or AAT1231-1. The value of the ballast resistor for each application is listed in Table 7.

Number of Parallel Strings	Total LED Current (A)	R1 (Ω) 1% Tolerance
10	0.20	3.01
9	0.18	3.32
8	0.16	3.74
7	0.14	4.32
6	0.12	4.99
5	0.10	6.04
4	0.08	7.50
3	0.06	10.0
2	0.04	15.0
1	0.02	30.1

Table 7: Ballast Resistor Values for Multi-String WLED Applications.

Ordering Information

Package	LED Current Control	Marking ¹	Part Number (Tape and Reel) ²
TSOPJW-12	Increasing	SDXYY	AAT1231ITP-T1
TSOPJW-12	Decreasing	TUXYY	AAT1231ITP-1-T1



All AnalogicTech products are offered in Pb-free packaging. The term “Pb-free” means semiconductor products that are in compliance with current RoHS standards, including the requirement that lead not exceed 0.1% by weight in homogeneous materials. For more information, please visit our website at <http://www.analogictech.com/about/quality.aspx>.

Package Information

TSOPJW-12

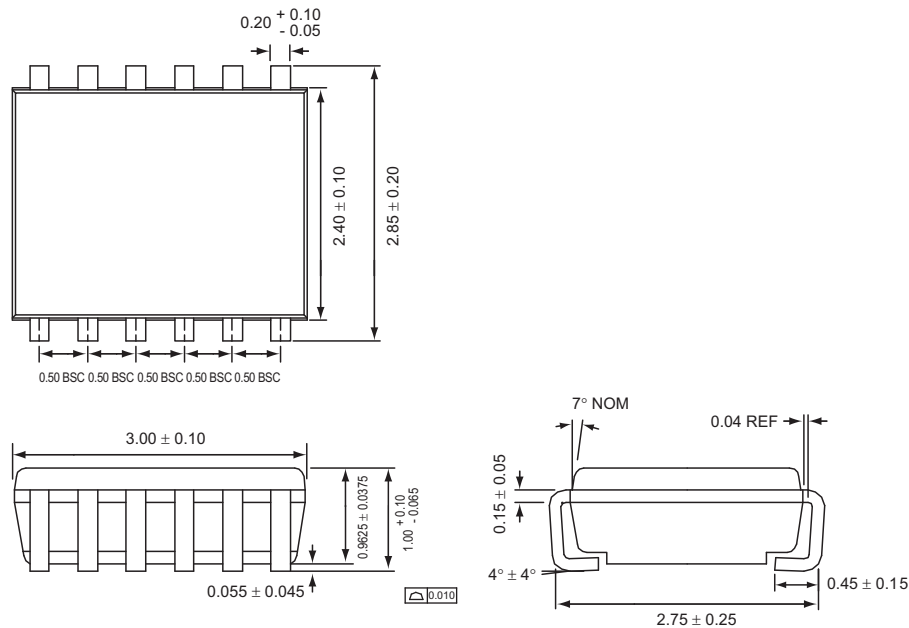

All dimensions in millimeters.

1. XYY = assembly and date code.
2. Sample stock is generally held on part numbers listed in **BOLD**.

Advanced Analogic Technologies, Inc.
 3230 Scott Boulevard, Santa Clara, CA 95054
 Phone (408) 737-4600
 Fax (408) 737-4611



© Advanced Analogic Technologies, Inc. AnalogicTech cannot assume responsibility for use of any circuitry other than circuitry entirely embodied in an AnalogicTech product. No circuit patent licenses, copyrights, mask work rights, or other intellectual property rights are implied. AnalogicTech reserves the right to make changes to their products or specifications or to discontinue any product or service without notice. Except as provided in AnalogicTech's terms and conditions of sale, AnalogicTech assumes no liability whatsoever, and AnalogicTech disclaims any express or implied warranty relating to the sale and/or use of AnalogicTech products including liability or warranties relating to fitness for a particular purpose, merchantability, or infringement of any patent, copyright or other intellectual property right. In order to minimize risks associated with the customer's applications, adequate design and operating safeguards must be provided by the customer to minimize inherent or procedural hazards. Testing and other quality control techniques are utilized to the extent AnalogicTech deems necessary to support this warranty. Specific testing of all parameters of each device is not necessarily performed. AnalogicTech and the AnalogicTech logo are trademarks of Advanced Analogic Technologies Incorporated. All other brand and product names appearing in this document are registered trademarks or trademarks of their respective holders.