

Description

GM6251 combines high accuracy with very low power consumption, and provides high output current even when the application requires extremely low input-output voltage dropout.

GM6251 includes a precision voltage reference, an error correction circuit, over-temperature protection, and a current limited output driver. Fast transient response to load variations provides excellent stability under dynamic loads.

GM6251 comes in SOT-25 (150mW), TO92 and SOT-89 (500mW).

Features

- ◆ Maximum output current up 300mA
- ◆ Output voltage from 1.5V to 5.0V in 0.1V increments
- ◆ Output voltage accuracy : $\pm 2\%$
- ◆ CMOS low power consumption, typically 1.0 μ A at $V_{OUT} = 5.0V$
- ◆ Input stability: typically 0.2%/V
- ◆ Ultra low dropout voltage: 0.38V @ $I_{OUT} = 200mV$ at $V_{OUT} = 5.0V$
- ◆ SOT-25 (150mW), SOT-89 (500mW) and TO-92 packages

Application

Palmtops

Portable Cameras

Video Recorders

Battery Powered Equipment

Reference Voltage Sources

Typical Application Circuits

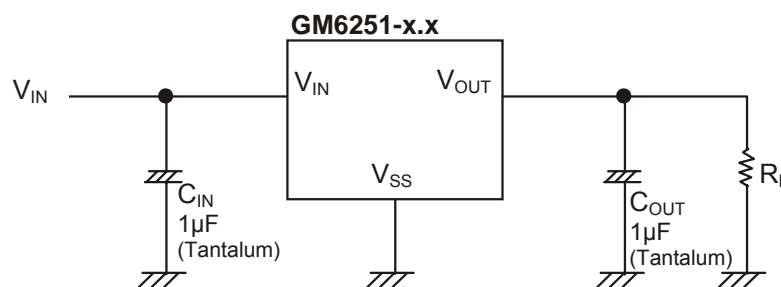

Marking Information and Pin Configurations (Top View)

SOT25

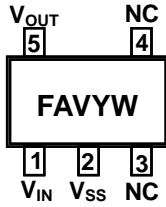

TO92

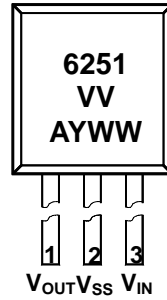

SOT89

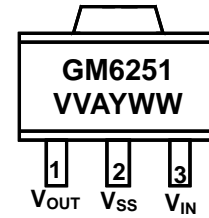

V: Voltage Code (see next page)

VV: Voltage suffix (18 = 1.8V, 50 = 5.0V...)

Y: Year

W: Week code

WW: Week

Ordering Information

Ordering Number	Output Voltage	Voltage Code	Package	Shipping
GM6251-1.8T92B	1.8V		TO-92	1,000 Units/Bag
GM6251-1.8T92RL			TO-92	2,000 Units/Ammo Pack (Tape)
GM6251-1.8ST25R		E	SOT-25	3,000 Units/Tape and Reel
GM6251-1.8ST89R			SOT-89	1,000 Units/Tape and Reel
GM6251-2.5T92B	2.5V		TO-92	1,000 Units/Bag
GM6251-2.5T92RL			TO-92	2,000 Units/Ammo Pack (Tape)
GM6251-2.5ST25R		G	SOT-25	3,000 Units/Tape and Reel
GM6251-2.5ST89R			SOT-89	1,000 Units/Tape and Reel
GM6251-2.7T92B	2.7V		TO-92	1,000 Units/Bag
GM6251-2.7T92RL			TO-92	2,000 Units/Ammo Pack (Tape)
GM6251-2.7ST25R		T	SOT-25	3,000 Units/Tape and Reel
GM6251-2.7ST89R			SOT-89	1,000 Units/Tape and Reel
GM6251-2.8T92B	2.8V		TO-92	1,000 Units/Bag
GM6251-2.8T92RL			TO-92	2,000 Units/Ammo Pack (Tape)
GM6251-2.8ST25R		H	SOT-25	3,000 Units/Tape and Reel
GM6251-2.8ST89R			SOT-89	1,000 Units/Tape and Reel
GM6251-3.0T92B	3.0V		TO-92	1,000 Units/Bag
GM6251-3.0T92RL			TO-92	2,000 Units/Ammo Pack (Tape)
GM6251-3.0ST25R		J	SOT-25	3,000 Units/Tape and Reel
GM6251-3.0ST89R			SOT-89	1,000 Units/Tape and Reel

Ordering Information (Continued)

Ordering Number	Output Voltage	Voltage Code	Package	Shipping
GM6251-3.2T92B	3.2V		TO-92	1,000 Units/Bag
GM6251-3.2T92RL			TO-92	2,000 Units/Ammo Pack (Tape)
GM6251-3.2ST25R		U	SOT-25	3,000 Units/Tape and Reel
GM6251-3.2ST89R			SOT-89	1,000 Units/Tape and Reel
GM6251-3.3T92B	3.3V		TO-92	1,000 Units/Bag
GM6251-3.3T92RL			TO-92	2,000 Units/Ammo Pack (Tape)
GM6251-3.3ST25R		K	SOT-25	3,000 Units/Tape and Reel
GM6251-3.3ST89R			SOT-89	1,000 Units/Tape and Reel
GM6251-3.5T92B	3.5V		TO-92	1,000 Units/Bag
GM6251-3.5T92RL			TO-92	2,000 Units/Ammo Pack (Tape)
GM6251-3.5ST25R		V	SOT-25	3,000 Units/Tape and Reel
GM6251-3.5ST89R			SOT-89	1,000 Units/Tape and Reel
GM6251-3.6T92B	3.6V		TO-92	1,000 Units/Bag
GM6251-3.6T92RL			TO-92	2,000 Units/Ammo Pack (Tape)
GM6251-3.6ST25R		L	SOT-25	3,000 Units/Tape and Reel
GM6251-3.6ST89R			SOT-89	1,000 Units/Tape and Reel
GM6251-4.0T92B	4.0V		TO-92	1,000 Units/Bag
GM6251-4.0T92RL			TO-92	2,000 Units/Ammo Pack (Tape)
GM6251-4.0ST25R		M	SOT-25	3,000 Units/Tape and Reel
GM6251-4.0ST89R			SOT-89	1,000 Units/Tape and Reel
GM6251-4.4T92B	4.4V		TO-92	1,000 Units/Bag
GM6251-4.4T92RL			TO-92	2,000 Units/Ammo Pack (Tape)
GM6251-4.4ST25R		W	SOT-25	3,000 Units/Tape and Reel
GM6251-4.4ST89R			SOT-89	1,000 Units/Tape and Reel
GM6251-4.5T92B	4.5V		TO-92	1,000 Units/Bag
GM6251-4.5T92RL			TO-92	2,000 Units/Ammo Pack (Tape)
GM6251-4.5ST25R		N	SOT-25	3,000 Units/Tape and Reel
GM6251-4.5ST89R			SOT-89	1,000 Units/Tape and Reel
GM6251-5.0T92B	5.0V		TO-92	1,000 Units/Bag
GM6251-5.0T92RL			TO-92	2,000 Units/Ammo Pack (Tape)
GM6251-5.0ST25R		Q	SOT-25	3,000 Units/Tape and Reel
GM6251-5.0ST89R			SOT-89	1,000 Units/Tape and Reel

Absolute Maximum Ratings

PARAMETER		SYMBOL	RATINGS	UNITS
Input Voltage		V_{IN}	12	V
Output Current		I_{OUT}	500	mA
Output Voltage		V_{OUT}	$V_{SS} - 0.3$ to $V_{IN} + 0.3$	V
Continuous Total Power Dissipation	SOT-25	P_D	150	mW
	SOT-89		500	
	TO-92		300	
Operating Ambient Temperature		T_A	- 40 to 125	
Storage Temperature		T_{stg}	- 65 to 150	

Block Diagram

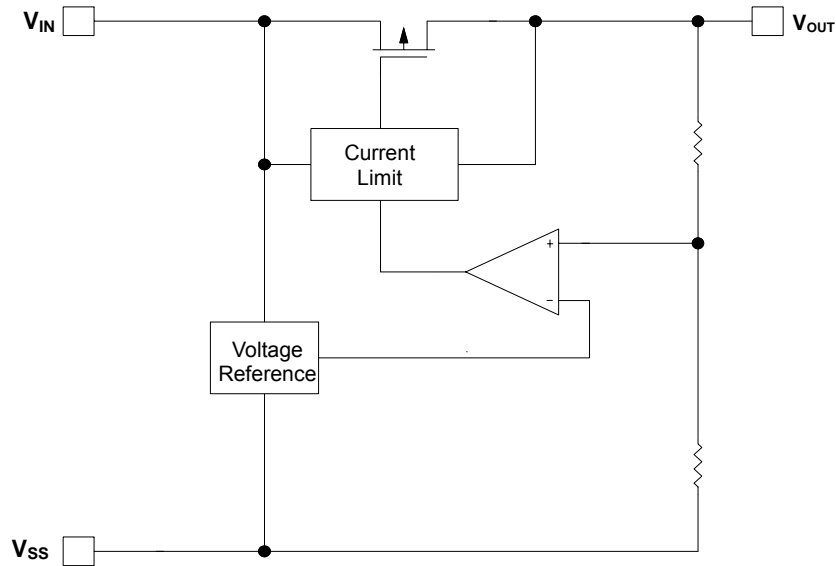

Electrical Characteristics ($T_A = 25^\circ\text{C}$, $V_{IN} = V_{OUT} + 1\text{V}$ unless otherwise noted)

Parameter		Symbol	Condition	Min	Typ	Max	Unit
Output Voltage	GM6251-1.8	V_{OUT}	$I_{OUT} = 40\text{mA}$, $V_{IN} = V_{OUT} + 1\text{V}$	1.764	1.800	1.836	V
	GM6251-2.5			2.450	2.500	2.550	
	GM6251-2.7			2.646	2.700	2.754	
	GM6251-2.8			2.744	2.800	2.856	
	GM6251-3.0			2.940	3.000	3.060	
	GM6251-3.2			3.136	3.200	3.264	
	GM6251-3.3			3.234	3.300	3.366	
	GM6251-3.5			3.430	3.500	3.570	
	GM6251-3.6			3.528	3.600	3.672	
	GM6251-4.0			3.920	4.000	4.080	
	GM6251-4.4			4.312	4.400	4.488	
	GM6251-4.5			4.410	4.500	4.590	
GM6251-5.0	4.900	5.000	5.100				
Line Regulation		ΔV_{OI}	$I_{OUT} = 40\text{mA}$, $V_{OUT} + 1\text{V} < V_{IN} < 10\text{V}$		0.2	0.3	%/V
Load Regulation		ΔV_{OL}	$1\text{mA} < I_{OUT} < 80\text{mA}$		0.02	0.03	%/mA
Dropout Voltage	$V_{OUT} > 2.5\text{V}$	ΔV	$I_{OUT} = 180\text{mA}$		0.4	0.7	V
	$2.0\text{V} < V_{OUT} < 2.5\text{V}$				0.55	0.85	
	$V_{OUT} < 2.0\text{V}$				0.9	1.3	
Current Consumption		I_Q			1.0	2.9	μA
Output Current Limit		I_{CL}		500			mA

Application Note

Notes on Usage

1. It is recommended to operate the GM6251 series within the stipulated absolute maximum ratings as the IC is liable to malfunction if it is operated outside the ratings.
2. There is a possibility of heat or oscillation as a result of the impedance present between the power supply and the IC's input. Where impedance is greater than 10Ω , it is recommended to use a capacitor (C_{IN}) of at least $1\mu F$ at the input terminal.
3. With a large output current, operations can be stabilized by increasing capacitor size (C_{IN}). If C_{IN} is too small and capacitance of (C_L) is increased, there is a possibility of oscillation due to input impedance. In such case, operation can be stabilized by either increasing the size of C_{IN} or decreasing the size of C_L .
4. Please ensure the output current (I_{OUT}) is less than $P_d \div (V_{IN} - V_{OUT})$ and does not exceed the stipulated continuous total power dissipation value (P_d) for the package.

CALCULATING POWER DISSIPATION

The GM6251 series precision linear regulators include thermal shutdown and current limit circuitry to protect the devices. However, high power regulators normally operate at high junction temperatures so it is important to calculate the power dissipation and junction temperatures accurately to be sure that you use an adequate heat sink.

The thermal characteristics of an IC depend on four factors:

1. Maximum Ambient Temperature T_A ()
2. Power Dissipation P_D (Watts)
3. Maximum Junction Temperature T_J ()
4. Thermal Resistance Junction to ambient R_{JA} (/W)

These relationships of these four factors is expressed by equation : $T_J = T_A + P_D \times R_{JA}$

Maximum ambient temperature and power dissipation are determined by the design while the maximum junction temperature and thermal resistance depend on the manufacturer and the package type.

Typical Performance Characteristics (for GM6251-3.0)

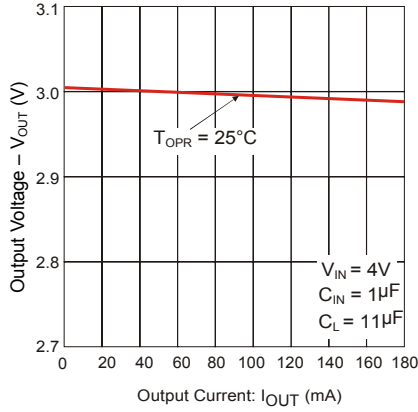

Figure 1: Output Voltage vs. Output Current

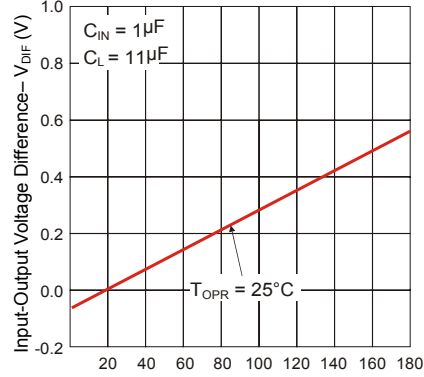

Figure 2: Input/ Output Voltage differential vs. Output Current

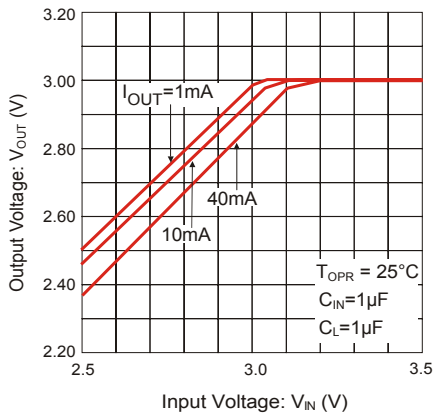

Figure 3: Output Voltage vs. Input voltage

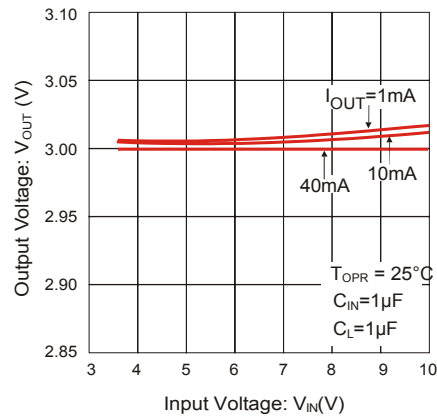

Figure 4: Output Voltage vs. Input voltage

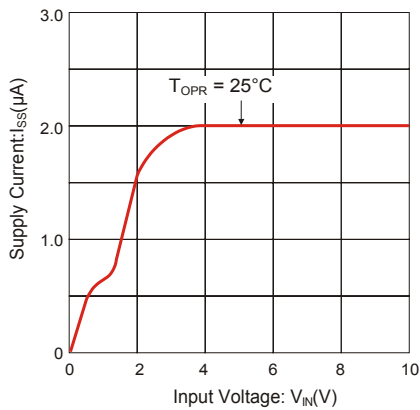

Figure 5: Supply Current vs. Input Voltage

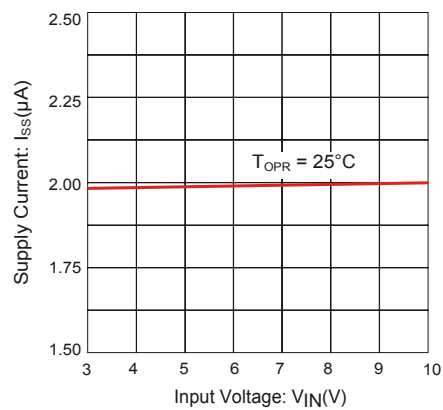

Figure 6: Supply Current vs. Input Voltage

Typical Performance Characteristics (for GM6251-3.0, continued)

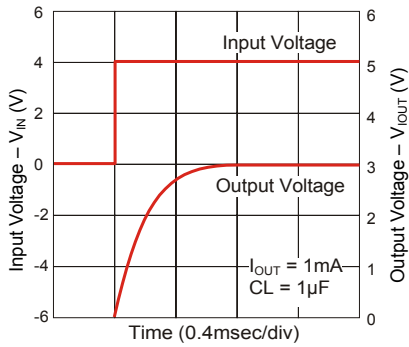

Figure 7: Input Transient Response 1

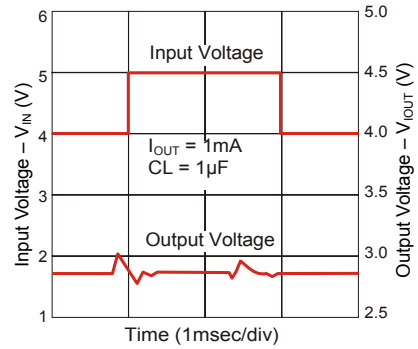

Figure 8: Input Transient Response 2

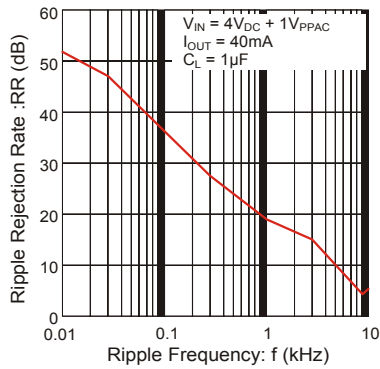
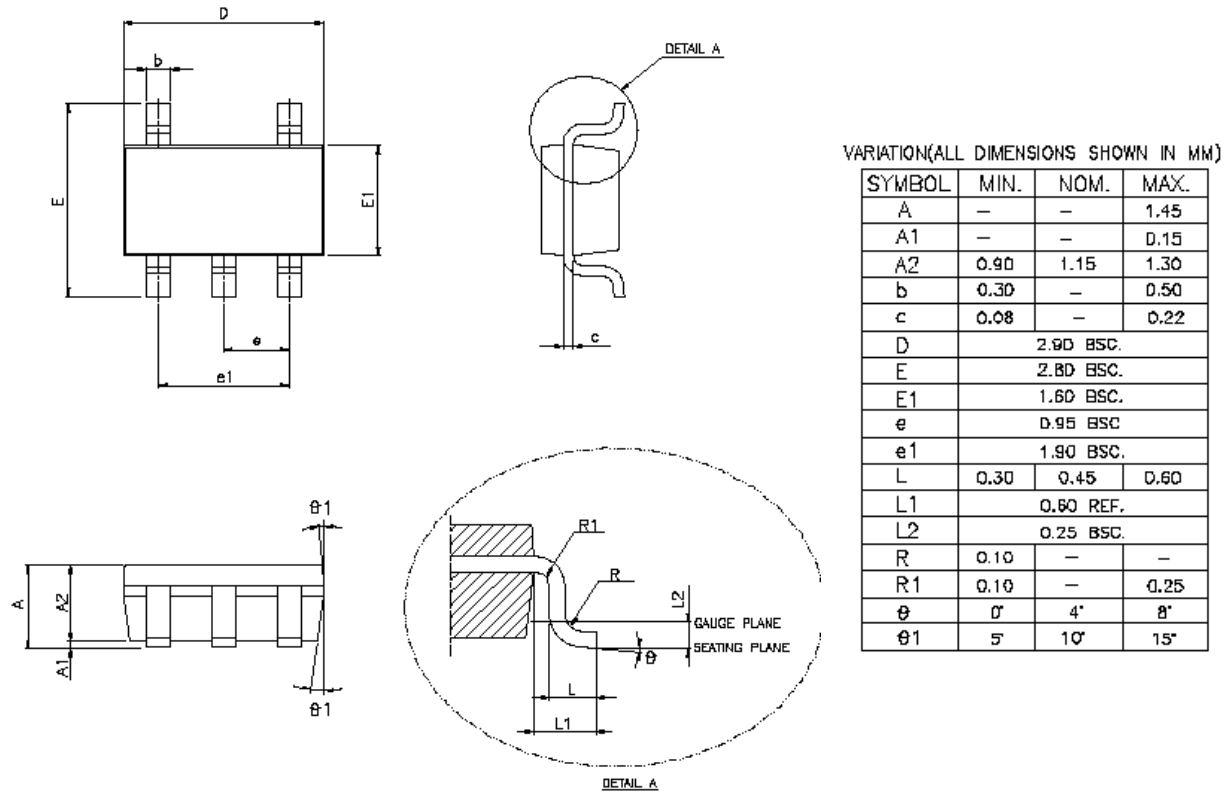
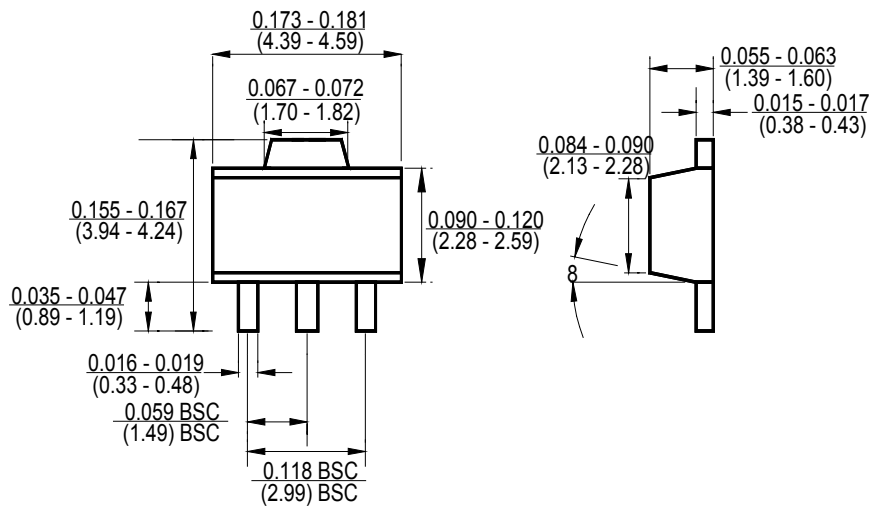

Figure 9: Ripple Rejection Rate

Package Outline Dimensions – SOT 25



Package Outline Dimensions – SOT 89



Package Outline Dimensions – TO 92

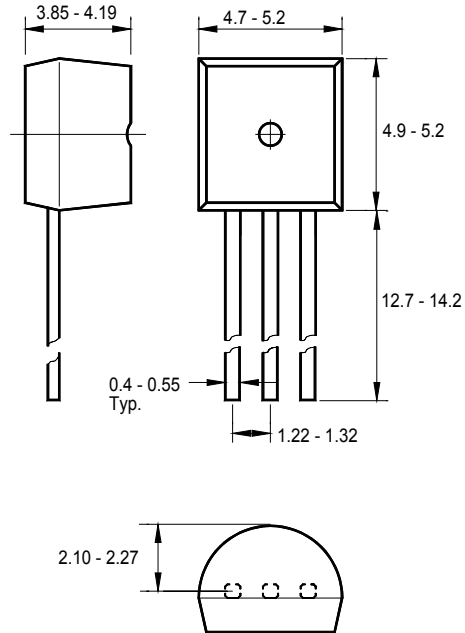

Dimensions are in millimeters

Ordering Number

GM 6251 - 1.8 T92 B

APM Gamma Micro	Circuit Type	Output Voltage	Package Type	Shipping Type
		1.8 = 1.8V	T92: TO 92	B: Bag
		2.5 = 2.5V	ST89: SOT 89	RL: Ammo Pack (Tape)
		3.3 = 3.3V	ST25: SOT 25	T: Tube
		5.0 = 5.0V		R: Tape & Reel