



SMT Power Inductors - LPT3305 Series



This product has been discontinued as of September 1, 2000

Recommended alternative is LPO2506 series. Existing customers will be supported. For more information, please contact Coilcraft.

These parts are designed for applications requiring low profile parts – 1.8 mm high. The toroid construction minimizes EMI while the ceramic cover provides the best possible surface for pick and place handling.

Applications include notebook computers and PC cards as well as wireless communication products.

Part number ¹	L ±20% ² (μH)	DCR max (Ohms)	SRF min (MHz)	Isat ³ (A)	Irms ⁴ (A)
LPT3305-102ML_	1.0	0.16	615	6.0	1.6
LPT3305-152ML_	1.5	0.18	355	4.7	1.5
LPT3305-222ML_	2.2	0.23	210	3.8	1.3
LPT3305-332ML_	3.3	0.26	175	3.3	1.3
LPT3305-472ML_	4.7	0.33	125	2.6	1.2
LPT3305-682ML_	6.8	0.40	105	2.1	1.1
LPT3305-103ML_	10	0.49	75	1.8	0.90
LPT3305-153ML_	15	0.75	55	1.4	0.85
LPT3305-223ML_	22	1.1	35	1.2	0.70
LPT3305-333ML_	33	1.4	20	1.0	0.65
LPT3305-473ML_	47	1.6	15	0.9	0.60

1. When ordering, please specify **packaging** code:

LPT3305-473ML D

Packaging: D = 13" machine-ready reel. EIA-481 embossed plastic tape (1700 parts per full reel).

B = Less than full reel. In tape, but not machine ready. To have a leader and trailer added (\$25 charge), use code letter C instead.

- Inductance tested at 100 kHz, 0.1 Vrms, 0 Adc.
- DC current at which the inductance drops 30% from its value without current.
- Operating temperature range -40°C to $+85^{\circ}\text{C}$.
- Electrical specifications at 25°C .

For environmental data see Product Specifications section.

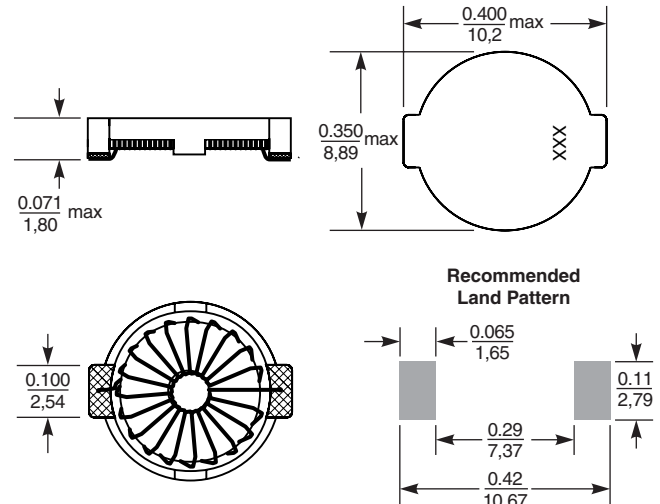

Terminations: Silver-palladium-platinum-glass frit
Tape and reel: 1700/13" reel 24 mm tape width
 For packaging data see Tape and Reel Specifications section.

Typical Inductance vs. Current

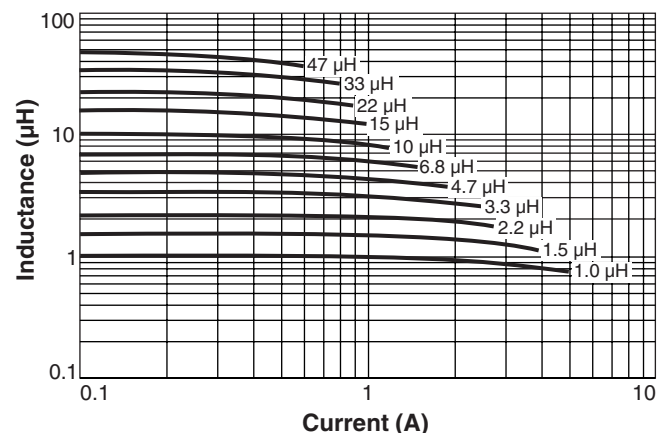

Coilcraft®

Specifications subject to change without notice.
 Please check our website for latest information.

Document 203 Revised 03/31/06

1102 Silver Lake Road Cary, Illinois 60013 Phone 847/639-6400 Fax 847/639-1469

E-mail info@coilcraft.com Web <http://www.coilcraft.com>