

CTDD3220DF-D1.5K-3W

Series

4:1 Wide Input Isolated & Regulated
3W Output, Dual Output

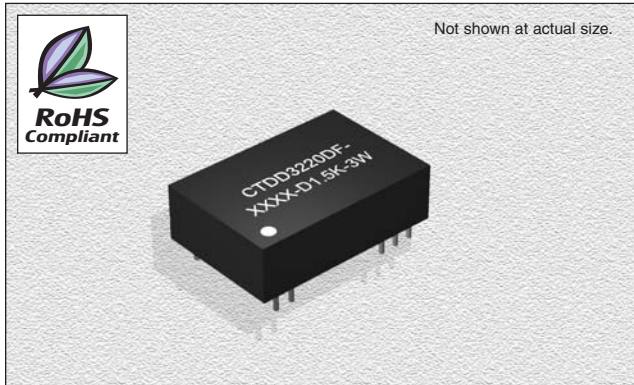

FEATURES

- Efficiency:** To 82%
- Temperature Range:** -40°C to +85°C
- Isolation:** 1.5KVDC
- Package:** UL94-V0
- Miscellaneous:** Wide (4:1) Input Range. Dual Output. No heat sink required. Continuous Short Circuit Protection.
- Samples available.**

CHARACTERISTICS

- Output Short Circuit Protection:** Continuous
- Temperature Rise at Full Load:** 30°C (Typ.)
- Cooling:** Free air convection
- Operating Temperature Range:** -40°C to +85°C
- Storage Temperature Range:** -55°C to +125°C
- Lead Temperature:** 300°C (1.5mm from case for 10 seconds)
- Storage Humidity Range:** ≤ 95%
- Case Material:** Pastic (UL94-V0)
- MTBF:** >1,000,000 hours
- Miscellaneous:** RoHS Compliant.

SPECIFICATIONS

Part Number	Vin Nom. (VDC)	Input Range (VDC)	Vin Max.* (VDC)	Vout (VDC)	Iout Max. (mA)	Iout Min. (mA)	Effi. Typ. (%)
CTDD3220DF-2405-D1.5K-3W	24	9-36	40	±5	±300	±30	74
CTDD3220DF-2412-D1.5K-3W	24	9-36	40	±12	±125	±12	81
CTDD3220DF-2415-D1.5K-3W	24	9-36	40	±15	±100	±10	81
CTDD3220DF-4805-D1.5K-3W	48	18-72	80	±5	±300	±30	77
CTDD3220DF-4812-D1.5K-3W	48	18-72	80	±12	±125	±12	84
CTDD3220DF-4815-D1.5K-3W	48	18-72	80	±15	±100	±10	82

*If Input voltage above specified may cause permanent damage to the device

ISOLATION SPECIFICATIONS

Item	Test Condition	MIN	TYP	MAX	Units
Isolation Voltage	Flash tested for 1 minute	1500			VDC
Isolation Resistance	Test at 500VDC	1000			MΩ

OUTPUT SPECIFICATIONS

Item	Test Condition	MIN	TYP	MAX	Units
3W Output Power		0.3		3	W
Voltage accuracy	Refer to Recommended Circuit		±1	±3	%
Load regulation	From 10% to 100% load			±2	%
Line regulation	Input Voltage from low to high			±1	%
Temperature drift (Vout)	Refer to Temp. Derating Graph			0.03	%/°C
Ripple	20Hz to 300KHz Bandwidth			40	mVp-p
Noise	DC-20MHz Bandwidth		100		mVp-p
Switching frequency			100-650(PFM)		KHz
Isolation Capacitance			150		PF

Note:

1. All specifications measured at TA=25°C, humidity<75%, nominal input voltage and rated output unless otherwise specified.

TYPICAL CHARACTERISTICS

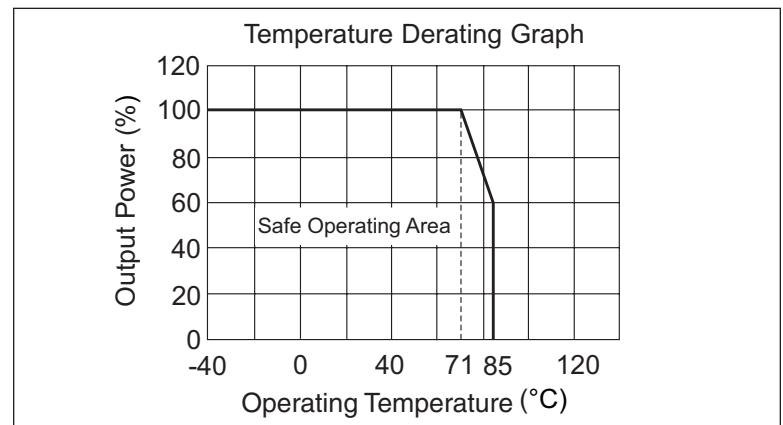

CTDD3220DF-D1.5K-3W Series

Wide Input Isolated & Regulated
3W Output, Dual Output

OUTLINE DIMENSIONS & RECOMMENDED FOOTPRINT DETAILS

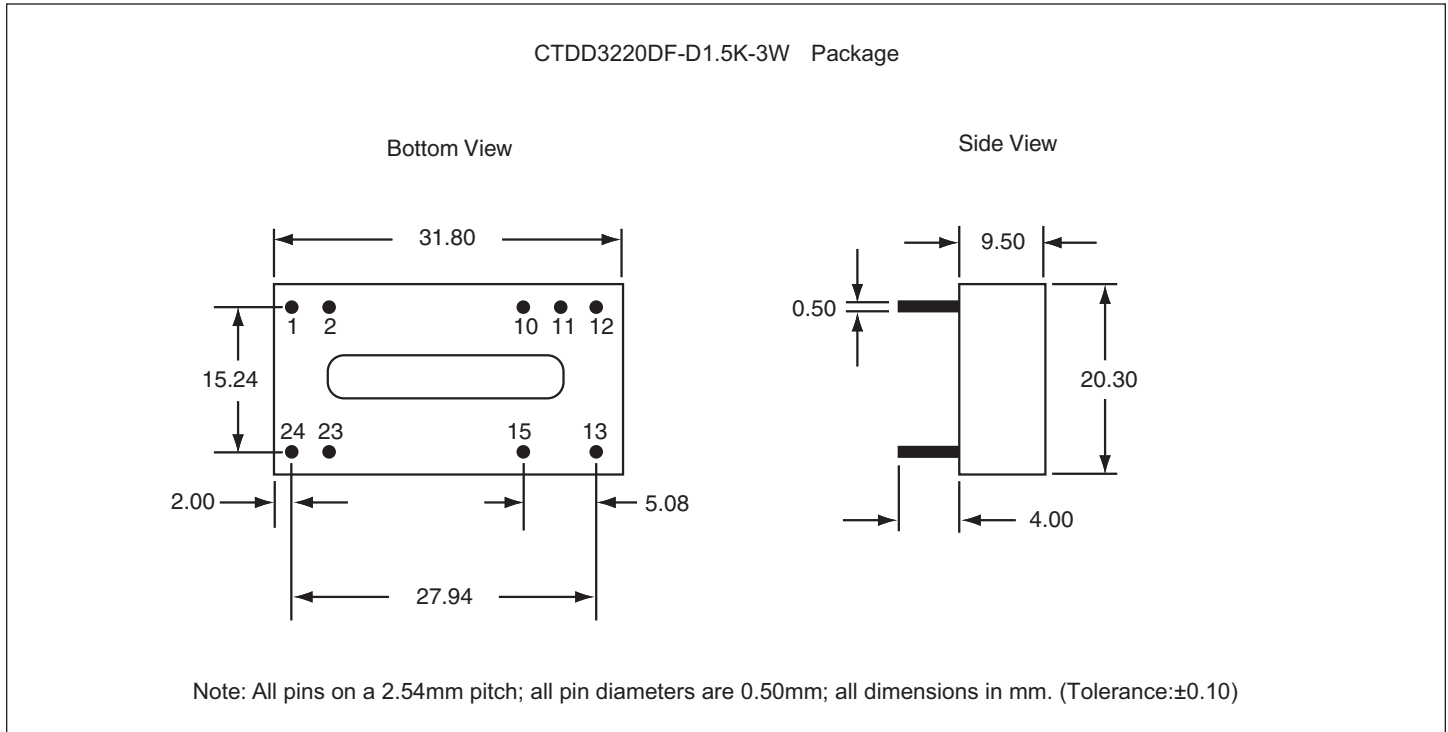

PIN CONNECTIONS

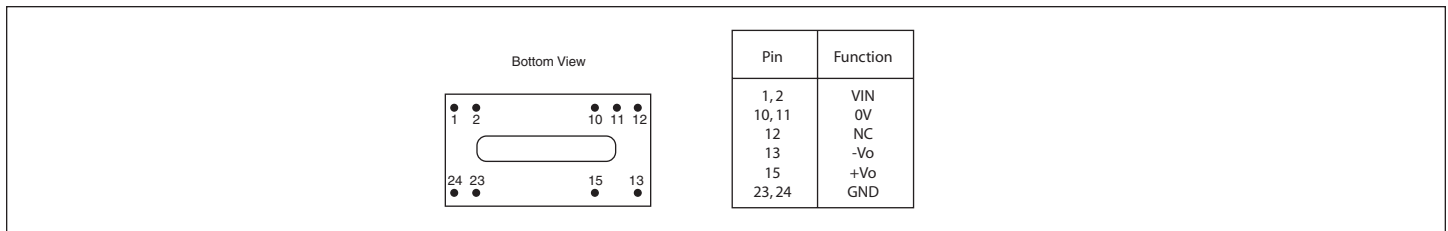

RECOMMENDED CIRCUIT

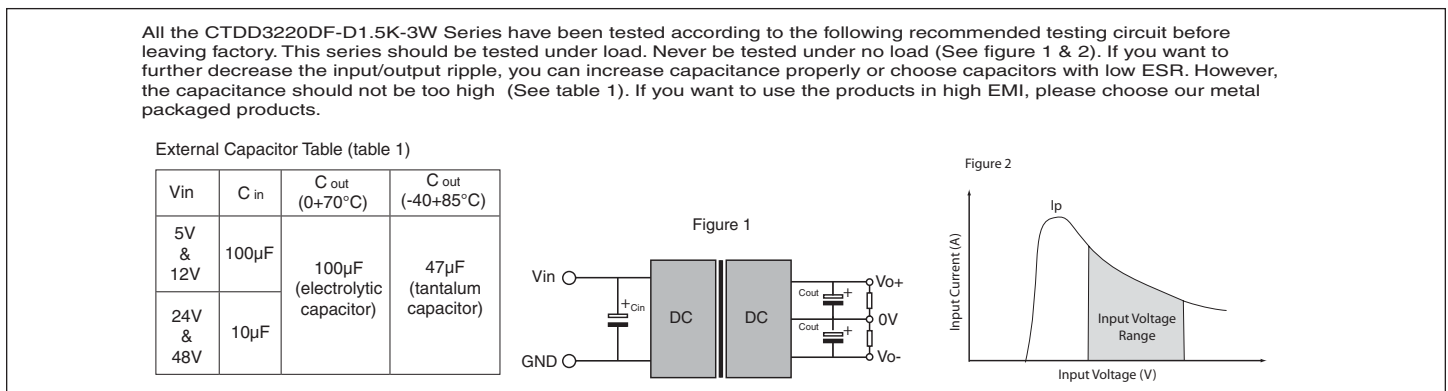

01.31.07