

# NLP150L Series

Single and triple outputs

- 90 Vac to 264 Vac universal input range
- Provides low voltage outputs of 3.3 V
- EN61000-3-2 compliant
- Overvoltage and short circuit protection
- Power fail detection
- Current sharing (on  $V_A$  and  $V_B$ )
- 3.8 x 6.8 x 1.26 inches
- UL, CSA and VDE safety approvals and CE-marked to LVD
- Compliance to EN55022-B conducted noise standard
- Compliance to EN55022-A radiated noise standard
- Meets all applicable and relevant immunity standards EN61000-4-2, -3, -4, -5 and -6
- Available RoHS compliant

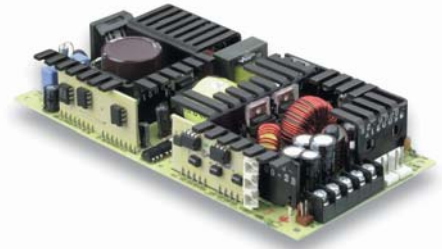

Patent No. 5600546 and 5652700

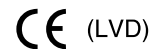

2 YEAR WARRANTY

The NLP150L series of 150 Watt ac-dc open-frame power supplies are available with single, triple or quad outputs. The single and triple output versions described in this datasheet are housed in a 3.8 x 6.8 x 1.26 inch package. All NLP150L series power supplies are harmonic current corrected to meet the EN61000-3-2 standard, and support current sharing. The power supplies are designed for use in 1U shelves or boxes, and are primarily intended for networking applications that have a heavy logic content, such as access concentrators, midrange routers, LAN switches and shared media hubs.

All specifications are typical at nominal input, full load at 25 °C unless otherwise stated

## SPECIFICATIONS

### OUTPUT SPECIFICATIONS

Total regulation (Line and load)	Main output	±2.0%
	Auxiliary outputs	±5.0%
Turn-on delay	@ 120 Vac Input	2.0 s, max.
Transient response	Main output	5.0% or 250 mV
	75% to 100% max. dev., 1 ms max. recovery to 1% step at 0.1 A/μs	
Temperature coefficient		±0.02%/°C
Overvoltage protection	Main outputs	125%, ±10%
Short circuit protection	Cyclic operation	Continuous
Minimum output current	Singles and multiple	See table

### INPUT SPECIFICATIONS

Input voltage range (See Note 12)	Universal input	90-264 Vac
Input frequency range		47-63 Hz
Input surge current	264 Vac (cold start)	40 A max.
Safety ground leakage current	264 Vac, 60 Hz	0.99 mA
Input current	120 Vac @ 150 W	1.95 A rms
	230 Vac @ 150 W	1.10 A rms
Input fuse	UL/IEC127	F3.15A H, 250 Vac

### EMC CHARACTERISTICS (10)

Conducted emissions	EN55022, FCC part 15	Level B
Radiated emissions	EN55022, FCC part 15	Level A
Harmonic current emission correction	EN61000-3-2	Compliant
ESD air	EN61000-4-2	Level 3
ESD contact	EN61000-4-2	Level 3

### EMC CHARACTERISTICS (continued) (10)

Surge	EN61000-4-5	Level 3
Fast transients	EN61000-4-4	Level 3
Radiated immunity	EN61000-4-3	Level 3
Conducted immunity	EN61000-4-6	Level 3

### GENERAL SPECIFICATIONS

Hold-up time	120 Vac @ 60 Hz	20 ms @ 150 W
Efficiency (See Note 13)	120 Vac @ 150 W	73% typical
Isolation voltage	Input/output	3000 Vac
	Input/chassis	1500 Vac
Approvals and standards pending	EN60950, VDE0805, IEC950 UL1950, CSA C22.2 No. 950	
Weight	540 g (19 oz)	
MTBF (@ 25 °C)	MIL-HDBK-217F Bellcore	350,000 hours min. 800,000 hours min.

### ENVIRONMENTAL SPECIFICATIONS (8)

Thermal performance	Operating ambient, (See derating curve)	0 °C to +50 °C
	Non-operating	-40 °C to +85 °C
	50 °C to 70 °C ambient, convection cooled	Derate to 50% load
	0 °C to 50 °C ambient, convection cooled	110 W
	0 °C to 50 °C ambient, 300 LFM forced air	150 W
	Peak (0 °C to +50 °C)	(See Note 3)
Relative humidity	Non-condensing	5% to 95% RH
Altitude	Operating	10,000 feet max.
	Non-operating	30,000 feet max.
Vibration (See Note 6)	5-500 Hz	2.4 G rms peak
Shock	per MIL-STD-810E	516.4 Part IV

# NLP150L Series

Single and triple outputs

For the most current data and application support visit [www.artesyn.com/powergroup/products.htm](http://www.artesyn.com/powergroup/products.htm)

OUTPUT VOLTAGE	OUTPUT CURRENT			RIPPLE (4)	TOTAL REGULATION	MODEL NUMBERS (14,15)
	MIN (5)	MAX (1)	300 LFM (2)			
3.3 V (V <sub>A</sub> )	1 A	22 A	30 A	50 mV	±2.0%	NLP150L-96S3J
5.1 V (V <sub>A</sub> )	1 A	22 A	30 A	50 mV	±2.0%	NLP150L-96S5J
+12 V (V <sub>A</sub> )	0.3 A	9.2 A	12.5 A	120 mV	±2.0%	NLP150L-96S6J
24 V (V <sub>A</sub> )	0.15 A	4.6 A	6.5 A	240 mV	±2.0%	NLP150L-96S8J
48 V (V <sub>A</sub> )	0.1 A	2.3 A	3.2 A	480 mV	±2.0%	NLP150L-96S9J
+5.1 V (V <sub>A</sub> )	1.5 A	20 A	30 A	50 mV	±2.0%	NLP150L-96T536J
+3.3 V (V <sub>B</sub> )	0.5 A	10 A	15 A	50 mV	±2.0%	
+12 V (V <sub>C</sub> )	0 A	2 A	3 A	120 mV	±5.0%	
+12 V (V <sub>A</sub> )	0.6 A	9.2 A	12.5 A	120 mV	±2.0%	NLP150L-96T658J
+5.1 V (V <sub>B</sub> )	0.5 A	6 A	8 A	50 mV	±2.0%	
+24 V (V <sub>C</sub> )	0 A	2 A	3 A	240 mV	±5.0%	

## Notes

- Free air convection.  
Multiple output units: maximum continuous output power not to exceed 110 W and the output current not to exceed:  $I_A + I_B + 2(I_C) \leq 23$  A.  
300 LFM forced air cooling from the longer side.  
Multiple output units: maximum continuous output power not to exceed 150 W and the output current not to exceed:  $I_A + I_B + 2(I_C) \leq 32$  A.
- Peak power at 115% lasting less than 30 seconds with duty cycle less than 5%. During peak loading, output voltage may exceed total regulation limits.
- Figure is peak-to-peak for room temperature rating. Output noise measurements are made across a 20 MHz bandwidth using a 6 inch twisted pair, terminated with a 10  $\mu$ F electrolytic capacitor and a 0.1  $\mu$ F ceramic capacitor.
- Minimum load required for correct start-up and operation on single outputs and on main output of multiple versions. Failure to observe minimum load on main output will not allow the supply to start-up correctly. Some electronic test loads have a large delay time before they start drawing current even though the voltage from the supply is present. During this time delay, there is no load on the output and as a result, the supply may not be able to start-up properly and maintain its correct output voltage. In these instances, a dummy resistive load across the output may be necessary to load the output of the supply until the test load can function correctly and draw the intended minimum load. Minimum load required on auxiliary outputs to maintain regulation.
- Three orthogonal axes, random vibration 10 minutes for each axes, 2.4 G rms 5 Hz to 500 Hz.
- For optimum reliability no part of the heatsink should exceed 110 °C and no semi-conductor case temperature should exceed 115 °C.
- CAUTION: Allow a minimum of 1 second after disconnecting line power when making thermal measurements.
- This product is only for inclusion by professional installers within other equipment and must not be operated as a stand alone product.
- Conducted EMI specifications reference measurements made with the power supply mounted on a grounded metal sheet extending 1 inch beyond each edge, using an unshielded cable. No external filtering required during conducted emissions testing but some applications may require additional filtering to achieve system compliance. Compliance with Radiated EMI specifications may require mounting in a suitable enclosure.
- All models require a minimum mounting stand-off of 6.35 mm (0.25 inches) in the end use product.
- Operational range 90 Vac to 264 Vac.
- For 3.3 V output (single), typical efficiency is 69%.
- The 'J' suffix indicates that these parts are Pb-free (RoHS 6/6) compliant. TSE RoHS 5/6 (non Pb-free) compliant versions may be available on special request, please contact your local sales representative for details.
- NOTICE: Some models do not support all options. Please contact your local Artesyn representative or use the on-line model number search tool at <http://www.artesyn.com/powergroup/products.htm> to find a suitable alternative.

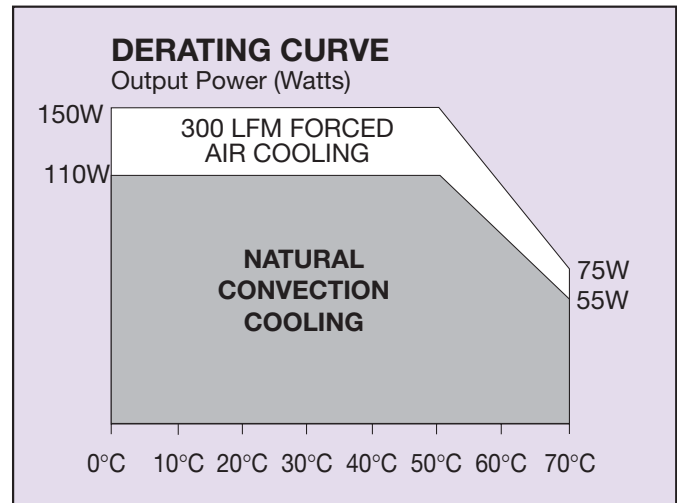

## International Safety Standard Approvals



VDE0805/EN60950/IEC950 File No. 10401-3336-0162  
Licence No. 123897



UL1950 File No. E136005

# NLP150L Series

## Single and triple outputs

LOW TO MEDIUM POWER AC/DC POWER SUPPLIES | 110-150 W AC/DC Universal Input Switch Mode Power Supplies | 3

For the most current data and application support visit [www.artesyn.com/powergroup/products.htm](http://www.artesyn.com/powergroup/products.htm)

### Mechanical Notes

A All dimensions are in inches (mm).

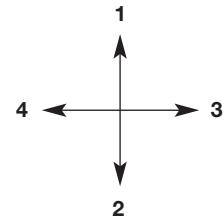
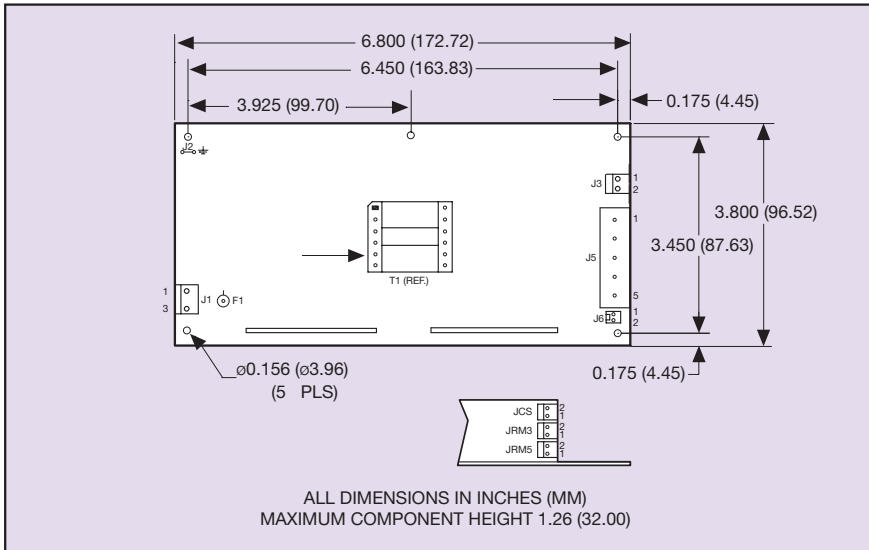

**Recommended direction for forced air relative to power supply orientation shown below.**

- 1 Best.
- 2 Good.
- 3 Not recommended.
- 4 Not recommended.

### CONNECTOR AND MATING CONNECTOR TYPES

CONNECTOR	TYPE	MATING CONNECTOR TYPE
J1	Molex 26-60-4030 or equivalent	Molex 09-50-3031 or equivalent with Molex 08-50-0105 or equivalent crimp terminals
J2	Male 0.250 quick disconnect	Molex AA-5261, AA22-01 or equivalent
J3	Molex 26-60-4040 or equivalent	Molex 09-50-3021 or equivalent with Molex 2478 phosphor bronze or equivalent crimp terminals
J5	Beau Interconnect 70505-C-50 or equivalent	N/A
J6	Molex 22-23-3021 or equivalent	Molex 22-01-2021 and contact 08-50-0113 terminals or equivalent
JRM3, JRM5 & JCS	Leoco 2421P02H000 or equivalent	Leoco 2420S02000 and contact 2453TPB00V1

#### J1 PIN CONNECTIONS

Pin 1	Neutral
Pin 2	Void
Pin 3	Line

#### J3 PIN CONNECTIONS

Pin 1	V <sub>D</sub> Positive
Pin 2	V <sub>D</sub> RTN

**Note:** V<sub>D</sub> is a floating output.  
It can be configured as positive or negative

#### J5 PIN CONNECTIONS

Pin 1	V <sub>A</sub> Positive
Pin 2	V <sub>A</sub> Positive
Pin 3	Main RTN
Pin 4	Main RTN
Pin 5	V <sub>B</sub> Positive

#### JRM5 PIN CONNECTIONS

Pin 1	V <sub>A</sub> Sense +
Pin 2	V <sub>A</sub> Sense -

#### J6 PIN CONNECTIONS

Pin 1	Signal
Pin 2	RTN

#### JCS PIN CONNECTIONS

Pin 1	Load A Current Sharing
Pin 2	Load B Current Sharing

#### JRM3 PIN CONNECTIONS

Pin 1	V <sub>B</sub> Sense +
Pin 2	V <sub>B</sub> Sense -

Datasheet © Artesyn Technologies® 2005

The information and specifications contained in this datasheet are believed to be correct at time of publication. However, Artesyn Technologies accepts no responsibility for consequences arising from printing errors or inaccuracies. The information and specifications contained or described herein are subject to change in any manner at any time without notice. No rights under any patent accompany the sale of any such product(s) or information contained herein.

Please consult our website for the following items: ✓ Application Note

[www.artesyn.com](http://www.artesyn.com)