

OV7675 VGA product brief



Higher Performance, Feature Rich VGA Sensor to Support Fast Growing Emerging Markets



available in
a lead-free
package

The OV7675 is a high performance VGA sensor designed specifically to address growing demand for consumer electronics from emerging markets. Its small optical format enables ultra-thin camera modules, which, combined with its excellent low-light performance, make it a very attractive solution for entry-level and mainstream mobile phones, notebooks, netbooks and webcams.

The OV7675 is a low-voltage color CMOS image sensor that supports the full functionality of a single chip VGA (640 x 480) camera in a small footprint package. The 1/9-inch OV7675 uses a unique 2.5-micron OmniPixel3-HS™ pixel design, which allows it to offer best-in-class low-light sensitivity (1800 mV/lux-sec), significantly reduced noise and outstanding color reproduction.

The OV7675 provides full-frame, sub-sampled, windowed images in VGA, QVGA and QQVGA formats via the control of the serial camera control bus (SCCB) interface. Its image array is capable of operating at up to 30 frames per second (fps) in full VGA resolution with complete user control over image quality, formatting and output data transfer.

All required image processing functions, including exposure control, gamma, white balance, color saturation, hue control, defective pixel canceling, noise canceling are programmable through the SCCB interface. In addition, OmniVision image sensors use proprietary sensor technology to improve image quality by reducing or eliminating common lighting/electrical sources of image contamination, such as fixed pattern noise and smearing to produce a clean, fully stable color image.

Find out more at www.ovt.com.

Applications

- Mobile Phones
- Notebooks/Netbooks and Webcams

Product Features

- support for image sizes: VGA (640 x 480), QVGA (320 x 240) and QQVGA (160 x 120)
- support for output formats: YUV4:2:2, Raw RGB, ITU656, RGB565
- digital video port (DVP) parallel output interface
- on-chip phase lock loop (PLL)
- built-in 1.5V regulator for core
- capable of maintaining register values at power down
- programmable controls for frame rate, mirror and flip, AEC/AGC, and windowing
- support for horizontal and vertical sub-sampling
- automatic image control functions:
 - automatic exposure control (AEC)
 - automatic white balance (AWB)
 - automatic black level calibration (ABLC)
- image quality controls: defect pixel correction and lens shading correction
- support for black sun cancellation
- standard serial SCCB interface
- parallel I/O tri-state configurability and programmable polarity
- module size: 6 mm x 6 mm

OV7675

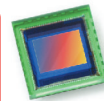

Ordering Information

- OV07675-A23A (color, lead-free, 23-pin CSP3)
- OV07675-G04A (color, chip probing, 200 μ m backgrinding, reconstructed wafer)
- OV07175-A23A (B&W, lead-free, 23-pin CSP3)

Product Specifications

- active array size: 640 x 480
- power supply:
 - analog: 2.6 - 3.0 V
 - core: 1.5 V \pm 5% (internal regulator)
 - I/O: 1.71 - 3.0 V
- power requirements:
 - active: 98 mW
 - standby: 60 μ W
- temperature range:
 - operating: -30°C to 70°C
 - stable image: 0°C to 50°C
- output formats: YUV422, RAW RGB, ITU656, RGB565
- lens size: 1/9"
- lens chief ray angle: 21°
- input clock frequency: 1.5 - 27 MHz
- scan mode: progressive
- maximum image transfer rate:
 - VGA: 30 fps
 - QVGA: 60 fps
 - QQVGA: 240 fps
- sensitivity: 1800 mV/(lux-sec)
- shutter: rolling shutter
- S/N ratio: 38 dB
- dynamic range: 71 dB
- maximum exposure interval: 510 x t_{ROW}
- pixel size: 2.5 μ m x 2.5 μ m
- image area: 1640 μ m x 1220 μ m
- package dimensions:
 - CSP3: 2815 μ m x 2825 μ m
 - COB: 2830 μ m x 2840 μ m

Functional Block Diagram

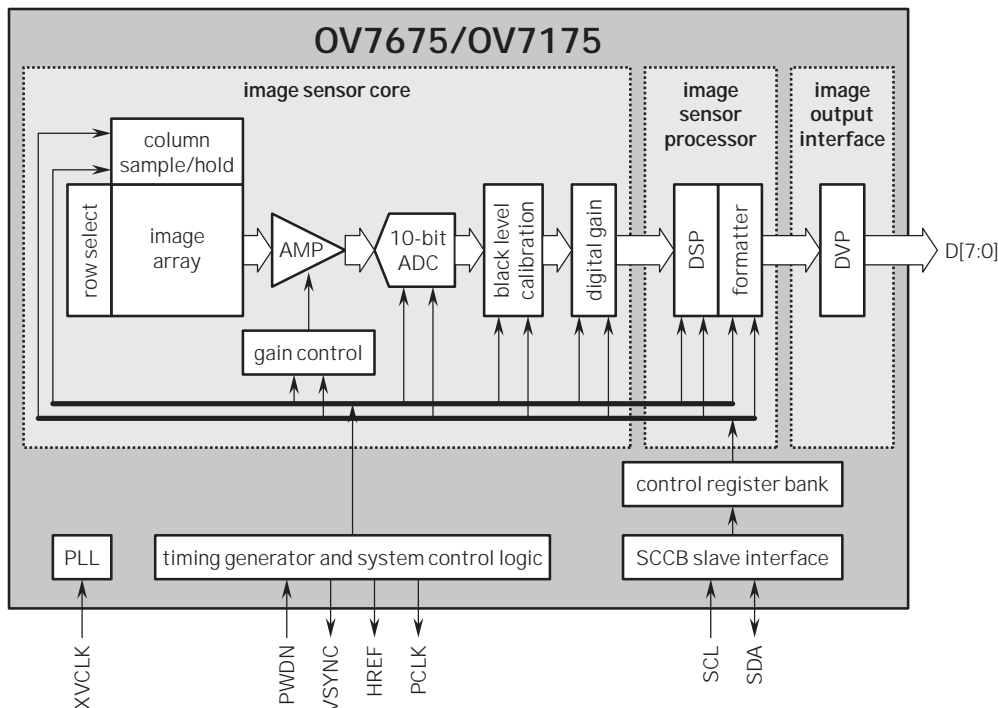

4275 Burton Drive
Santa Clara, CA 95054
USA

Tel: + 1 408 567 3000
Fax: + 1 408 567 3001
www.ovt.com

OmniVision reserves the right to make changes to their products or to discontinue any product or service without further notice. OmniVision and OmniPixel are registered trademarks of OmniVision Technologies, Inc. The OmniVision logo and OmniPixel3-HS are trademarks of OmniVision Technologies, Inc. All other trademarks are the property of their respective owners.