



6-Channel Low Noise Charge Pump White LED Driver



FEATURES

- Drives up to 4 main LEDs and 2 sub LEDs
- Separate control for main and sub LEDs
- Compatible with supply voltage of 3V to 5.5V
- Power efficiency up to 90%
- Output current up to 30mA per LED
- High-frequency Operation at 1MHz
- 2 modes of operation 1x and 1.5x
- White LED detect circuitry on all channels
- Shutdown current less than 1µA
- Small ceramic capacitors
- Soft start and current limiting
- Short circuit protection
- 16-pad TQFN package, 0.8mm max height

APPLICATION

- Cell phone main and sub-display backlight
- Navigation
- PDAs
- Digital Cameras

ORDERING INFORMATION

Part Number	Package	Quantity per Reel	Marking
CAT3606HV4-T2	TQFN-16 ⁽¹⁾	2000	G366
CAT3606HV4-GT2	TQFN-16 ⁽²⁾	2000	CDBB

Notes: (1) Matte-Tin Plated Finish (RoHS-compliant).
 (2) NiPdAu Plated Finish (RoHS-compliant).

DESCRIPTION

The CAT3606 controls up to four LEDs for the main display and two LEDs for the sub-display in cellular phones. The device is capable of operating in either 1x (LDO) mode or 1.5x charge pump mode. All LED pin currents are regulated and tightly matched to achieve uniformity of brightness across the LCD backlight. An external resistor (R_{SET}) sets the nominal output current.

The device can deliver as much as 20mA per channel during low voltage operation (3V), and 30mA per channel during nominal operation (3.3V). A constant high-frequency switching scheme (1MHz) provides low noise and allows the use of very small value ceramic capacitors..

A “zero” quiescent current mode can be achieved via the chip enable pin EN. The Main and Sub LEDs each have their own dedicated ON/OFF control pins ENM, ENS Dimming can be achieved using either a DC voltage to control the R_{SET} pin current, or by applying a PWM signal on the ENM and ENS pins.

The device is available in a 16-pad TQFN package with a max height of 0.8mm.

For Ordering Information details, see page 11.

TYPICAL APPLICATION CIRCUIT

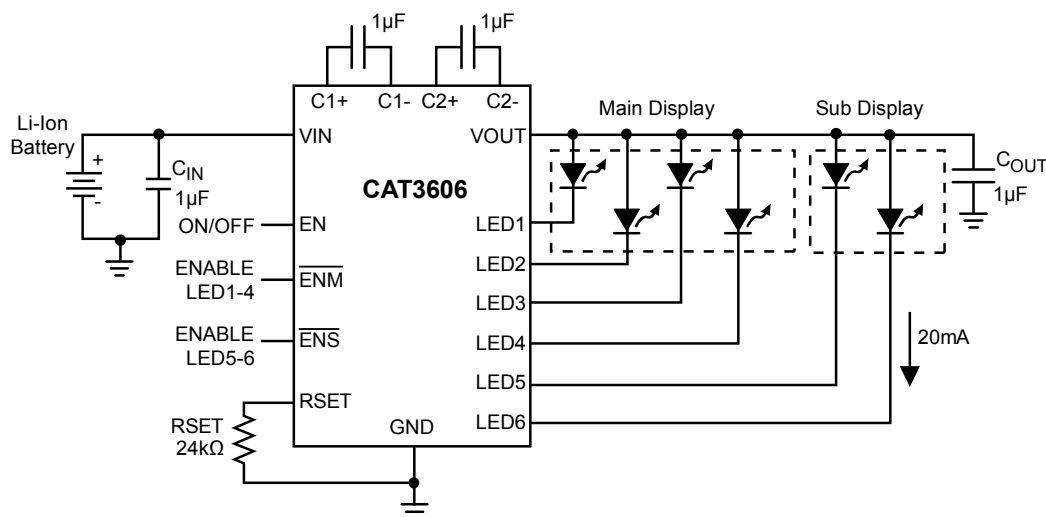

PIN CONFIGURATION ⁽¹⁾

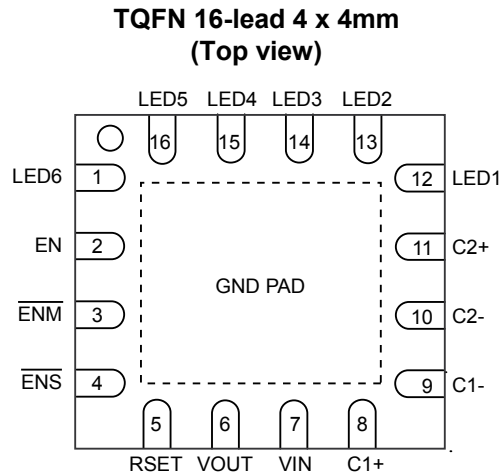

PIN DESCRIPTIONS

Pin Number	Name	Function
1	LED6	LED6 cathode terminal
2	EN	Enable/shutdown input, active high
3	$\overline{\text{ENM}}$	Enable "main" input for LED1 to LED4, active low
4	$\overline{\text{ENS}}$	Enable "sub" input for LED5 and LED6, active low
5	RSET	The LED output current is set by the current sourced out of the RSET pin
6	VOUT	Charge pump output connected to the LED anodes
7	VIN	Supply voltage
8	C1+	Bucket capacitor 1 terminal
9	C1-	Bucket capacitor 1 terminal
10	C2-	Bucket capacitor 2 terminal
11	C2+	Bucket capacitor 2 terminal
12	LED1	LED 1 cathode terminal
13	LED2	LED 2 cathode terminal
14	LED3	LED 3 cathode terminal
15	LED4	LED 4 cathode terminal
16	LED5	LED 5 cathode terminal
PAD	GND	Ground reference

Notes:

(1) The "exposed pad" under the package must be connected to the ground plane on the PCB.

ABSOLUTE MAXIMUM RATINGS

Parameter	Rating	Unit
V _{IN} , V _{OUT} , LED _x voltage	-0.3 to 7.0	V
EN, ENM, ENS voltage	-0.3 to V _{IN}	V
RSET voltage	-0.3 to V _{IN}	V
RSET current	± 1	mA
Ambient Temperature Range	-40 to +85	°C
Storage Temperature Range	-65 to +160	°C
Lead Temperature	300	°C
ESD Ratings		
Human Body Model (HBM)	2000	V
Machine Model (MM) ⁽¹⁾	200	V

RECOMMENDED OPERATING CONDITIONS

Parameter	Range	Unit
V _{IN}	3.0 to 5.5	V
Ambient Temperature Range	-40 to +85	°C
Input/Output/Bucket Capacitors	1 ± 20% Typical	µF
I _{LED} per LED pin	0 to 30	mA
I _{OUT} Total Output Current	0 to 150	mA

ELECTRICAL OPERATING CHARACTERISTICS

Limits over recommended operating conditions unless specified otherwise. Typical values at T_A = 25°C, V_{IN} = 3.5V, I_{RSET} = 5µA.

Symbol	Parameter	Conditions	Min	Typ	Max	Unit
I _Q	Quiescent Current	V _{EN} = 0V 1x Mode, No Load 1.5x Mode, No Load		0.1 0.3 2.6	1 1 5	µA mA mA
V _{RSET}	RSET Regulated Voltage		1.17	1.2	1.23	V
I _{LED}	Programmed LED Current	I _{RSET} = 5µA I _{RSET} = 37µA I _{RSET} = 78µA		2.4 15.0 30.0		mA
I _{LED}	LED Current Range with 6 LEDs	3.3 ≤ V _{IN} ≤ 4.5V 3.0 ≤ V _{IN} ≤ 4.5V			30 20	mA
I _{LED}	LED Current Range with 4 LEDs	3.3 ≤ V _{IN} ≤ 4.5V			30	mA
I _{LED-ACC}	LED Current Accuracy	0.5mA ≤ I _{LED} ≤ 3mA 3mA ≤ I _{LED} ≤ 30mA		±15 ±5		%
I _{LED-DEV}	LED Channel Matching	(I _{LED} - I _{LEDAVG}) / I _{LEDAVG}		±3		%
R _{OUT}	Output Resistance (Open Loop)	1x Mode, 1.5x mode, I _{OUT} = 100mA		1.4 6.5	2.5 10	Ω Ω
f _{OSC}	Charge Pump Frequency		0.8	1.0	1.3	MHz
T _{DROPOUT}	1x to 1.5x Mode Transition Dropout Delay		0.4	0.6	0.9	ms
I _{EN-CTR}	Input Leakage Current	On Inputs EN, ENM, ENS			1	µA
V _{EN-CTR}	High Detect Threshold Low Detect Threshold	On Inputs EN, ENM, ENS	0.4	0.8 0.7	1.3	V
I _{SC}	Input Current Limit	V _{OUT} = GND	30	45	60	mA
I _{LIM}	Maximum Input Current	V _{OUT} > 1V	200	400	600	mA

Notes:

(1) Machine model is with 200pF capacitor discharged directly into each pin.

BLOCK DIAGRAM

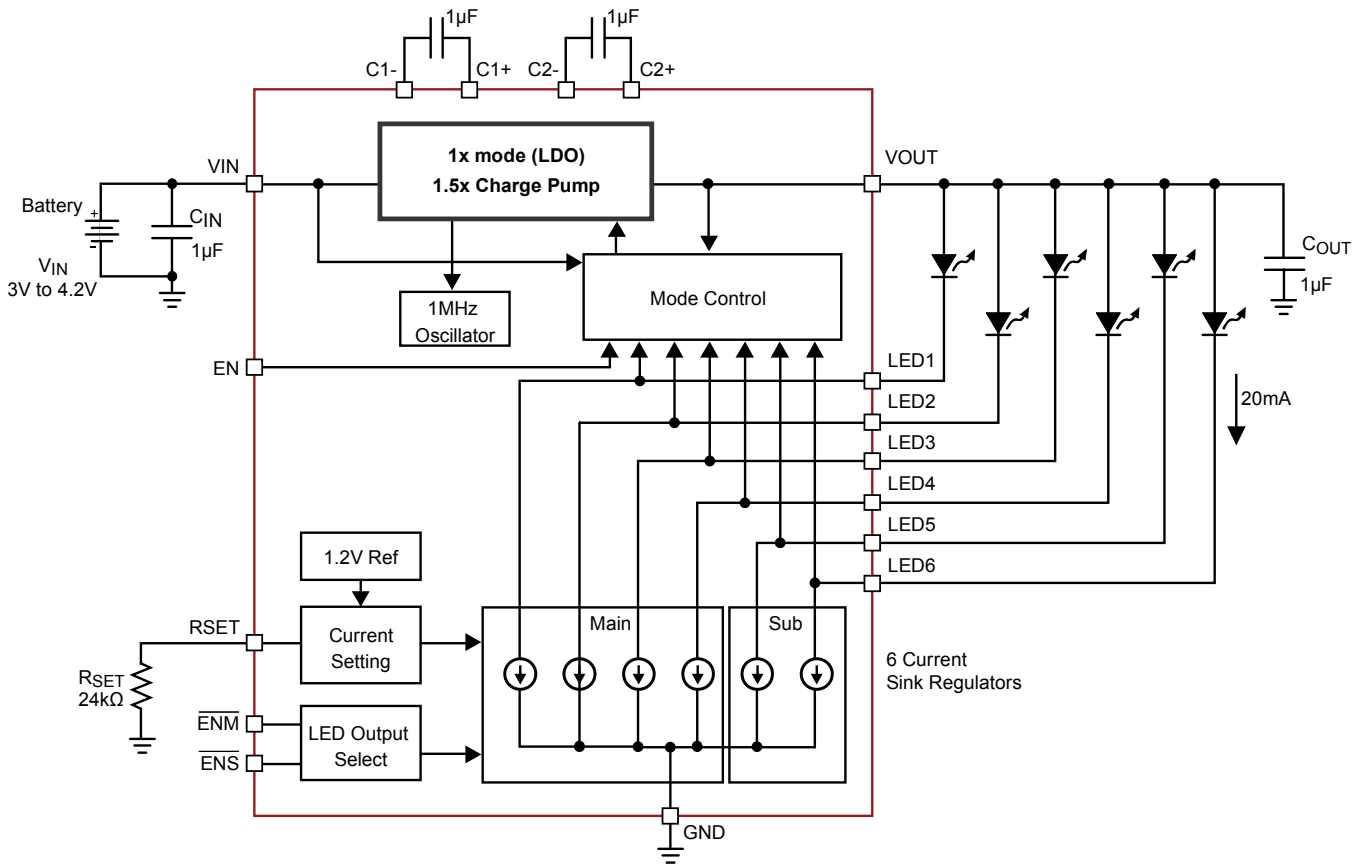

Figure 2. CAT3606 Functional Block Diagram

BASIC OPERATION

At power-up, the CAT3606 starts operation in 1x mode. If it is able to drive the programmed LED current, it continues in 1x mode. If the battery voltage drops to a level where the LED current cannot be met, the driver automatically switches into 1.5x mode, to boost the output voltage high enough to achieve the nominal LED current.

The above sequence is reinitialized each and every time the chip is powered up or is taken out of shutdown mode (via EN pin). The use of the Main and Sub display enable pins (ENM or ENS) does not affect the mode of operation.

LED CURRENT SETTING

The LED current is set by the external resistor RSET connected between the RSET pin and ground. Table 1 lists various LED currents and the associated RSET resistor value for standard 1% precision surface mount resistors.

Table 1. RSET Resistor Selection

LED Current (mA)	R _{SET} (kΩ)
1	649
2	287
5	102
10	49.9
15	32.4
20	23.7
30	15.4

The enable lines $\overline{\text{ENM}}$ and $\overline{\text{ENS}}$ allow to turn On or Off a group of LEDs as shown in Table 2.

Table 2: LED Selection

Control Lines			LED Outputs	
EN	$\overline{\text{ENM}}$	$\overline{\text{ENS}}$	Main LED1 - LED4	Sub LED5 -LED6
0	X	X	–	–
1	1	1	–	–
1	0	1	ON	–
1	1	0	–	ON
1	0	0	ON	ON

Notes: 1 = logic high (or VIN)
 0 = logic low (or GND)
 – = LED output OFF
 X = don't care

The unused LED channels can also be turned off by connecting the respective LED pins to VOUT. In which case, the corresponding LED driver is disabled and the typical LED Sink current is only about 0.2mA. When the following equation is true on any channel, the driver turns off the LED channel:

$$V_{\text{OUT}} - V_{\text{LED}} \leq 1\text{V (LED channel OFF)}$$

Note: The CAT3606 is designed to drive LEDs with forward voltage greater than 1V and is not compatible with resistive loads.

TYPICAL CHARACTERISTICS

$V_{IN} = 3.6V$, $EN = V_{IN}$, $\overline{ENM} = \overline{ENS} = GND$, $C_{IN} = C_{OUT} = 1\mu F$, $R_{SET} = 24k\Omega$ (20mA per LED), $T_{AMB} = 25^\circ C$, unless otherwise specified.

Efficiency vs. Input Voltage (6 LEDs)

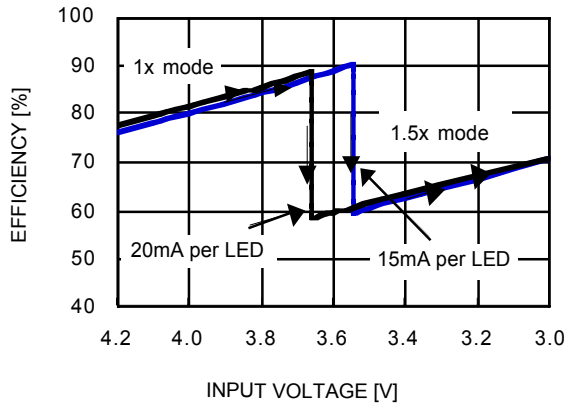

Efficiency vs. Total LED Current (6 LEDs)

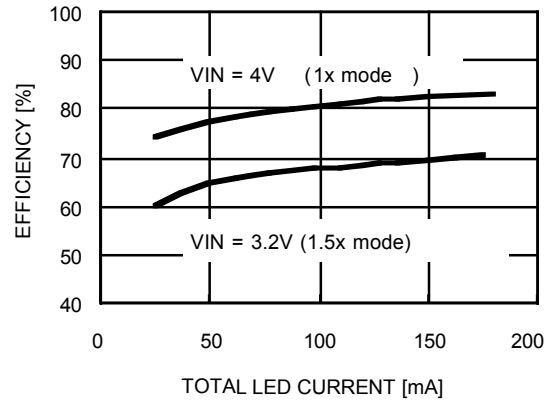

LED Current Change vs. Input Voltage

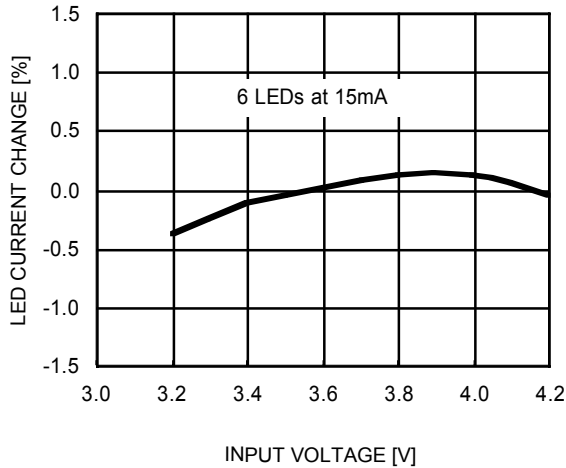

LED Current Change vs. Temperature

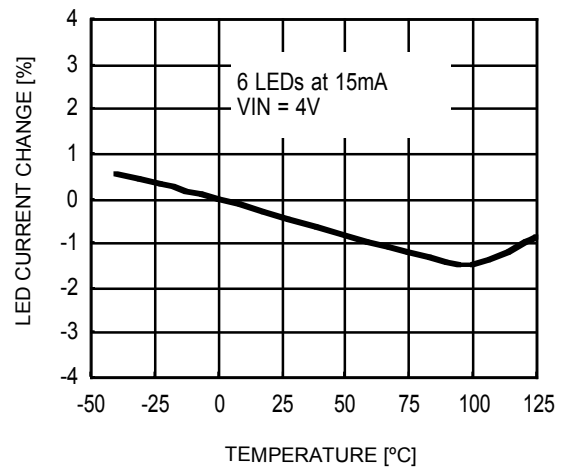

Ground Current vs. Input Voltage (1x mode)

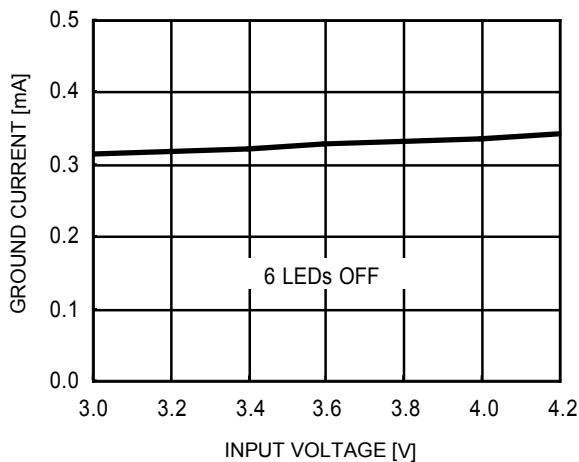

Ground Current vs. Temperature (1x mode)

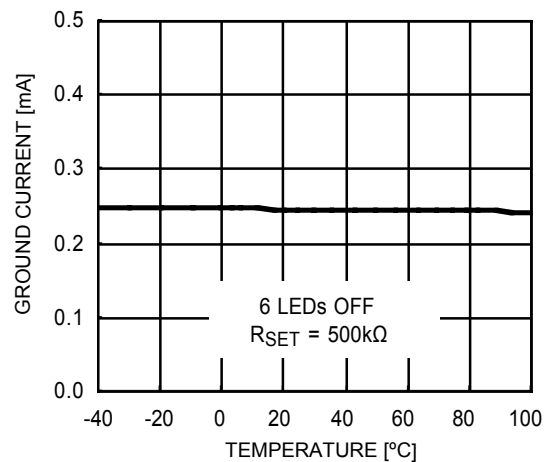

TYPICAL CHARACTERISTICS

V_{IN} = 3.6V, EN = V_{IN}, ENM = ENS = GND, C_{IN} = C_{OUT} = 1μF, R_{SET} = 24kΩ (20mA per LED), T_{AMB} = 25°C, unless otherwise specified.

Ground Current vs. Input Voltage (1.5x mode)

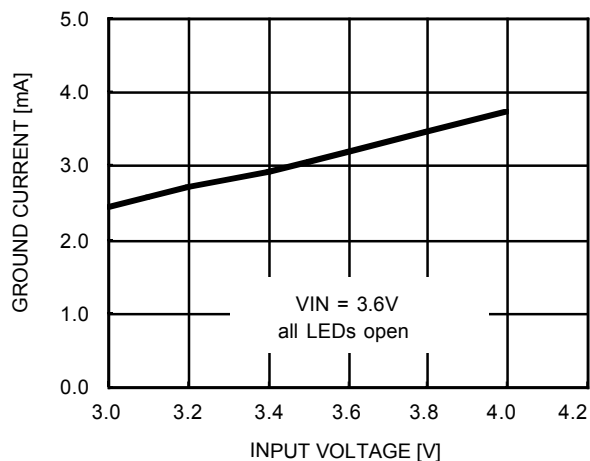

Supply Current vs. Input Voltage

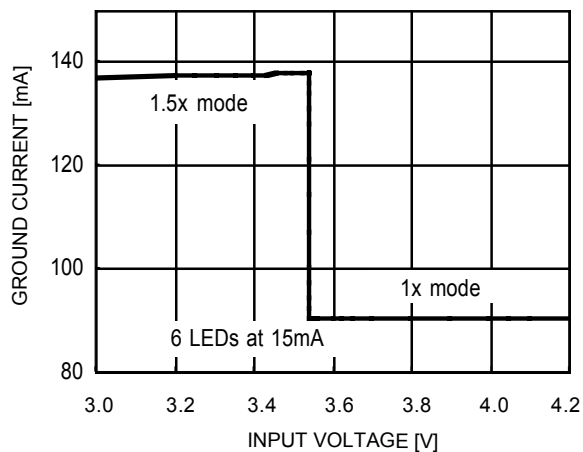

Oscillator Frequency vs. Input Voltage

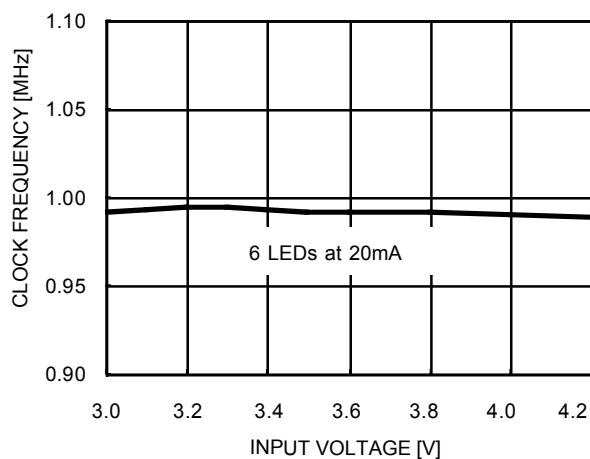

Oscillator Frequency vs. Temperature

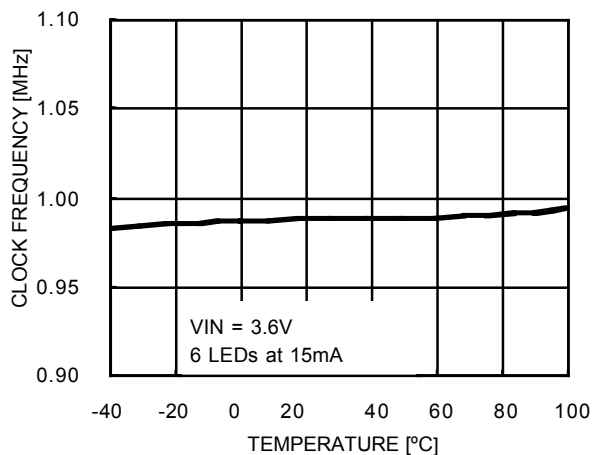

Output Resistance vs. Input Voltage (1x mode)

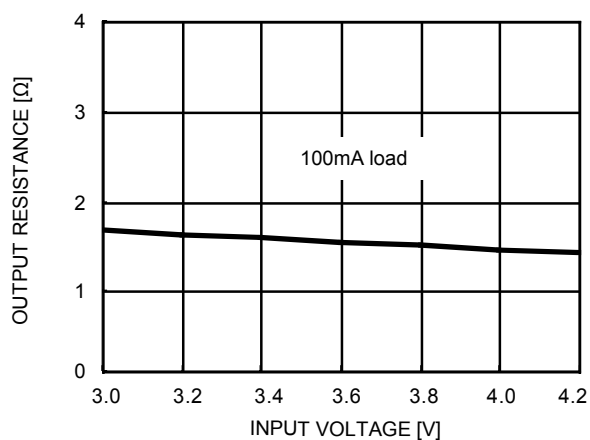

Output Resistance vs. Input Voltage (1.5x mode)

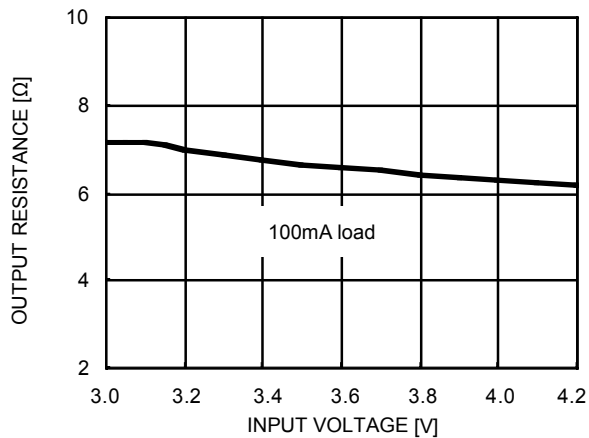

TYPICAL CHARACTERISTICS

VIN = 3.6V, EN = VIN, ENM = ENS = GND, CIN = COUT = 1μF, RSET = 24kΩ (20mA per LED), TAMB = 25°C, unless otherwise specified.

Switching Waveforms in 1.5x Mode

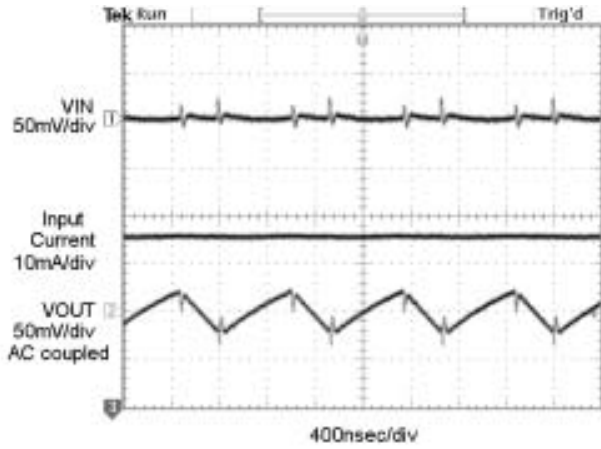

Operating Waveforms in 1x Mode

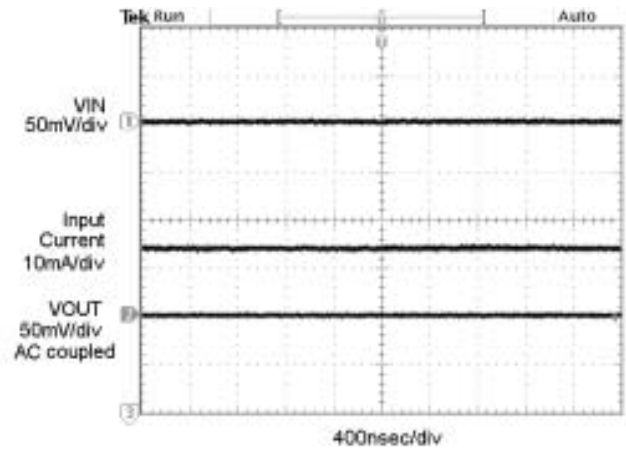

Power Up 6 LEDs at 15mA, VIN = 3V (1.5x Mode)

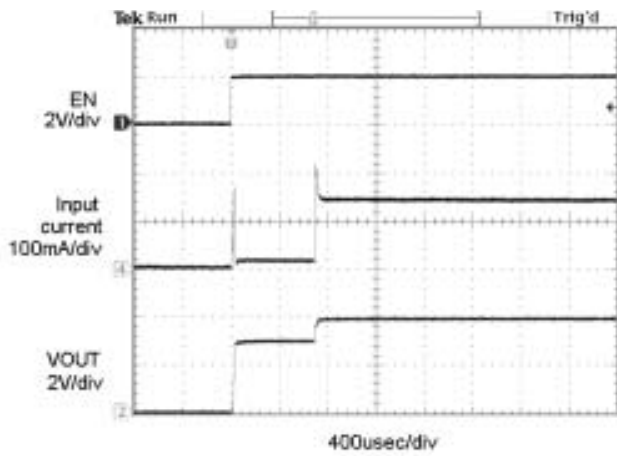

Power Up 6 LEDs at 15mA, VIN = 3.6V (1x Mode)

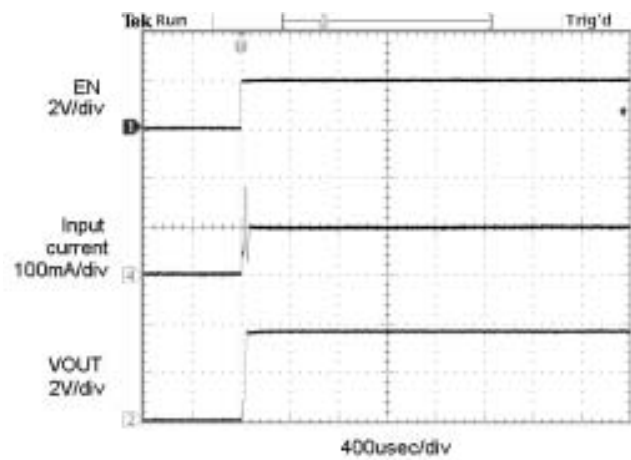

LED Current vs. RSET

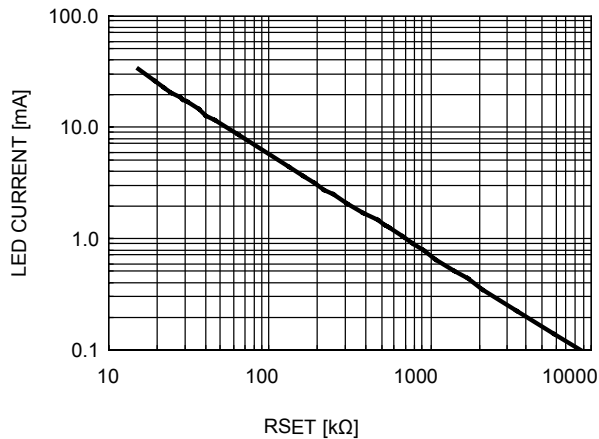

Line Transient Response in 1x Mode

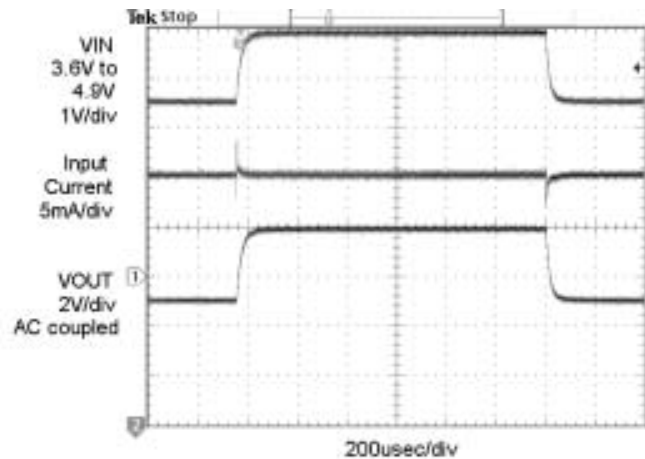

TYPICAL CHARACTERISTICS

V_{IN} = 3.6V, EN = V_{IN}, ENM = ENS = GND, C_{IN} = C_{OUT} = 1μF, T_{AMB} = 25°C, unless otherwise specified.

Foldback Current Limiting

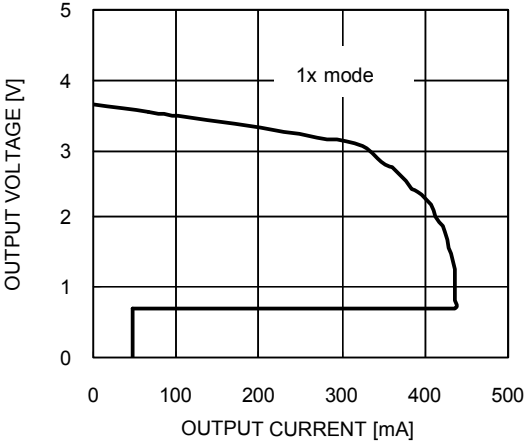

RSET Pin Voltage vs. Temperature

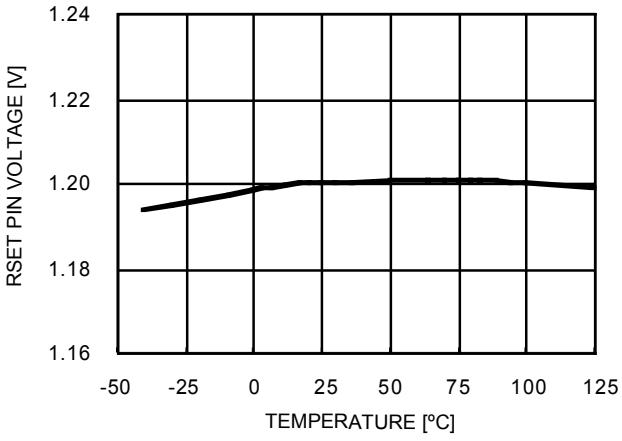

PWM Dimming at 1kHz on ENM and ENS

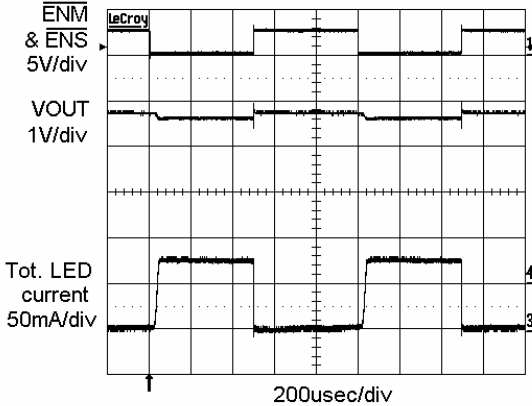

RECOMMENDED LAYOUT

When the driver is in the 1.5x charge pump mode, the 1MHz switching frequency operation requires to minimize trace length and impedance to ground on all 4 capacitors. A ground plane should cover the area on the bottom side of the PCB opposite to the IC and the bypass capacitors. Capacitors C_{in} and C_{out} require short connection to ground which can be done with multiple vias as shown on Figure 2. A square copper area matches the QFN16 exposed pad (GND) and must be connected to the ground plane underneath. The use of multiple via will improve the heat dissipation.

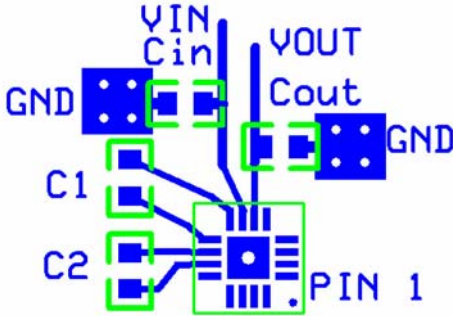
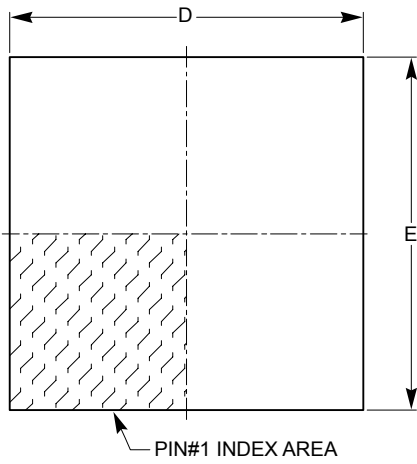

Figure 2. PCB Layout

PACKAGE OUTLINE DRAWING

TQFN 16-Pad 4 x 4mm (HV4) ⁽¹⁾⁽²⁾



TOP VIEW

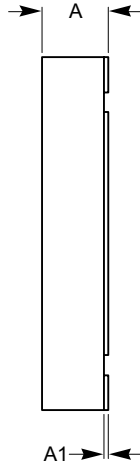

SIDE VIEW

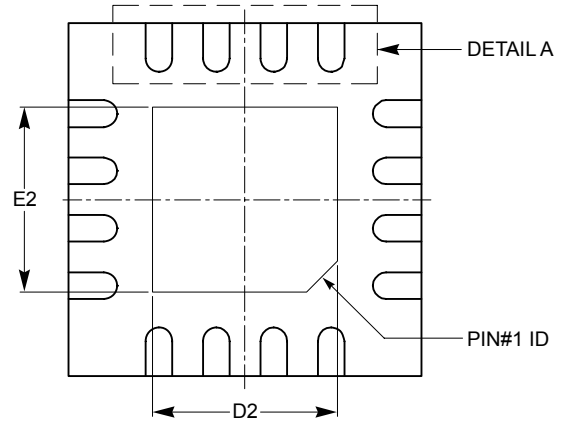

BOTTOM VIEW

SYMBOL	MIN	NOM	MAX
A	0.70	0.75	0.80
A1	0.00	0.02	0.05
A3	0.20 REF		
b	0.25	0.30	0.35
D	3.90	4.00	4.10
D2	2.00	–	2.25
E	3.90	4.00	4.10
E2	2.00	–	2.25
e	0.65 BSC		
L	0.45	–	0.65

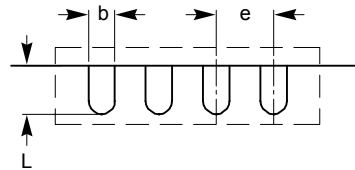

DETAIL A

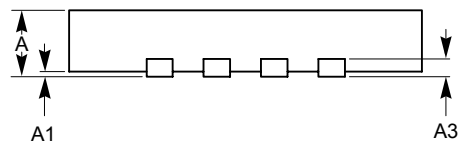

FRONT VIEW

For current Tape and Reel information, download the PDF file from:
<http://www.catsemi.com/documents/TapeandReel.pdf>

Notes:

- (1) All dimensions are in millimeters.
- (2) Complies with JEDEC standard MO-220.

EXAMPLE OF ORDERING INFORMATION

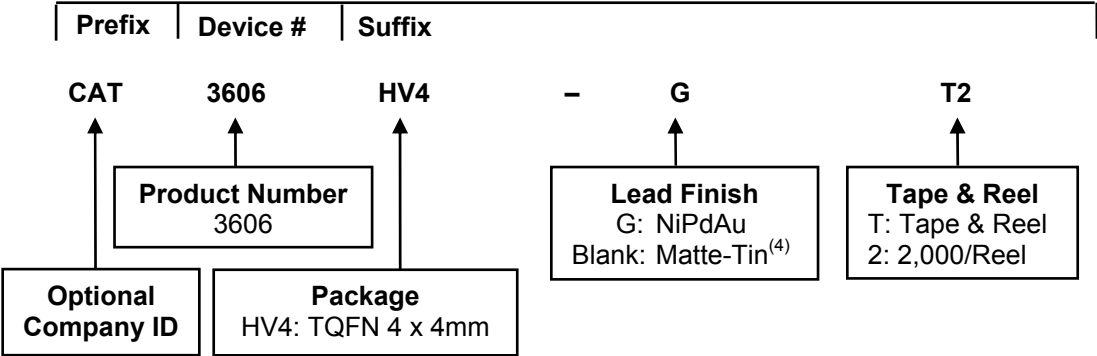

For Product Top Mark Codes, click here:
<http://www.catsemi.com/techsupport/producttopmark.asp>

Notes:

- (1) All packages are RoHS-compliant (Lead-free, Halogen-free).
- (2) The standard lead finish is NiPdAu.
- (3) The device used in the above example is a CAT3606HV4-GT2 (TQFN, NiPdAu Plated Finish, Tape & Reel, 2,000/Reel).
- (4) For Matte-Tin package option, please contact your nearest ON Semiconductor Sales office.

REVISION HISTORY

Date	Rev.	Reason
21-Jan-05	A	Initial Issue
8-Jan-05	B	Updated LED Current Setting
30-May-08	C	Update Package Outline Drawing Delete PbSn plated finish; add NiPdAu plated finish Add Example of Ordering Information Add Top Mark Code Link Add MD- to document number
12-Nov-08	D	Change logo and fine print to ON Semiconductor

ON Semiconductor and  are registered trademarks of Semiconductor Components Industries, LLC (SCILLC). SCILLC reserves the right to make changes without further notice to any products herein. SCILLC makes no warranty, representation or guarantee regarding the suitability of its products for any particular purpose, nor does SCILLC assume any liability arising out of the application or use of any product or circuit, and specifically disclaims any and all liability, including without limitation special, consequential or incidental damages. "Typical" parameters which may be provided in SCILLC data sheets and/or specifications can and do vary in different applications and actual performance may vary over time. All operating parameters, including "Typicals" must be validated for each customer application by customer's technical experts. SCILLC does not convey any license under its patent rights nor the rights of others. SCILLC products are not designed, intended, or authorized for use as components in systems intended for surgical implant into the body, or other applications intended to support or sustain life, or for any other application in which the failure of the SCILLC product could create a situation where personal injury or death may occur. Should Buyer purchase or use SCILLC products for any such unintended or unauthorized application, Buyer shall indemnify and hold SCILLC and its officers, employees, subsidiaries, affiliates, and distributors harmless against all claims, costs, damages, and expenses, and reasonable attorney fees arising out of, directly or indirectly, any claim of personal injury or death associated with such unintended or unauthorized use, even if such claim alleges that SCILLC was negligent regarding the design or manufacture of the part. SCILLC is an Equal Opportunity/Affirmative Action Employer. This literature is subject to all applicable copyright laws and is not for resale in any manner.

PUBLICATION ORDERING INFORMATION

LITERATURE FULFILLMENT:

Literature Distribution Center for ON Semiconductor
P.O. Box 5163, Denver, Colorado 80217 USA
Phone: 303-675-2175 or 800-344-3860 Toll Free USA/Canada
Fax: 303-675-2176 or 800-344-3867 Toll Free USA/Canada
Email: orderlit@onsemi.com

N. American Technical Support: 800-282-9855 Toll Free USA/Canada
Europe, Middle East and Africa Technical Support:
Phone: 421 33 790 2910
Japan Customer Focus Center:
Phone: 81-3-5773-3850

ON Semiconductor Website: www.onsemi.com
Order Literature: <http://www.onsemi.com/orderlit>
For additional information, please contact your local Sales Representative