



**Huck  
Fasteners**

From Cordant Technologies

# NOSE ASSEMBLY DATA SHEET

Yellow marking on anvil  
of LGP® fasteners.

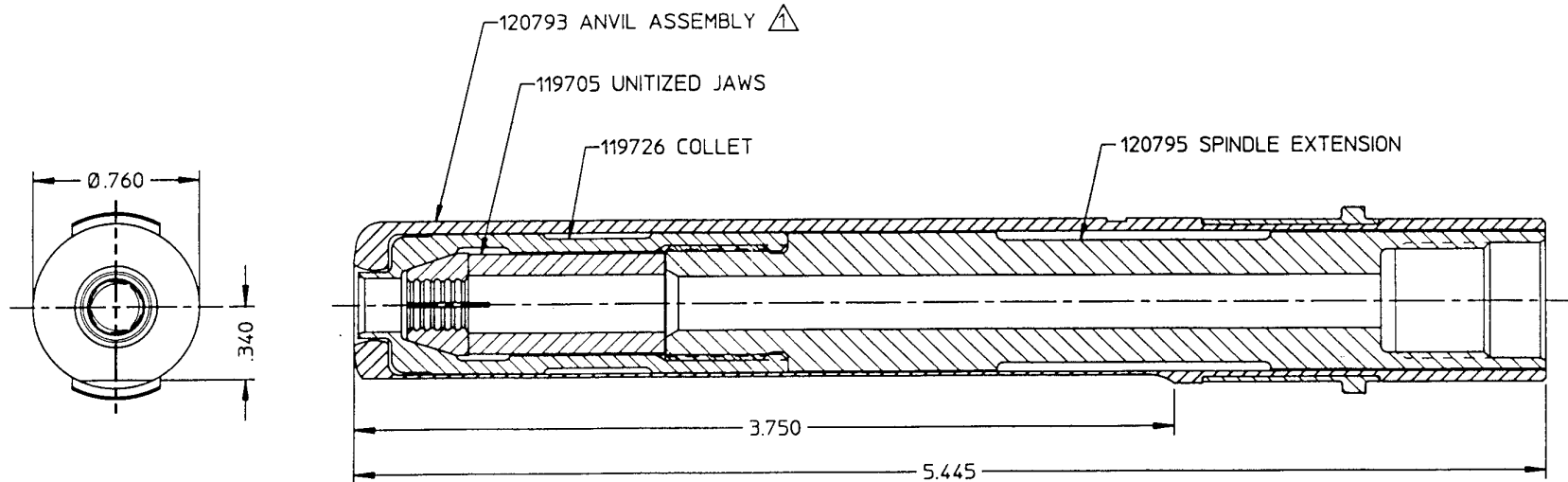

©Huck International, Inc. 1995  
 ©Registered Trademark of Huck International, Inc., Irvine, CA  
 ™Trademark of Huck International, Inc., Irvine, CA

Aluminum pins only in 352 Tool

<b>99-2514</b>	<b>Huck International, Inc.</b> Installation System Division 1 Corporate Drive - Kingston, NY 12401	
	<b>TYPE:</b> Non Self-releasing, Long <b>FOR:</b> HUCKBOLT LGP -08 <b>TOOL:</b> 230; 352; 2400; 2702	
	<b>OTHER</b>	<b>ISSUED:</b> 11-91 <b>REVISED:</b>

NOTES:

ANVIL ASSEMBLY P/N 120793 CONSISTS OF:  
 ANVIL P/N 120790 AND  
 RETAINER 120738  
 NOT AVAILABLE SEPARATELY.

## Nose Assembly Maintenance

1. Prepare tool per manual - remove any shims from spindle/rod with small pick. Select pintail tube below to prevent small diameter pintails from jamming in pull piston or spindle.

**Fastener** 200/210/212/230/352

**Dia.** 2400/2702\*

-04(1/8) 100534-1

-05(5/32) 100534-1

-06k08(3/16-1/4) None req'd.

\*Tube available separately.

### WARNING

**Before maintenance or adjustments:**  
**POWERIG Hydraulic Unit must be disconnected from electrical or air supply; air operated tools must be disconnected from air supply. If not disconnected, severe personal injury and/or damage may result.**

#### 2. Tools that use hydraulic source:

Connect tool's hoses and controls to POWERIG Hydraulic Unit. Reconnect power source. Depress trigger for 30 seconds. Disconnect controls and **RETURN** hose - **tool piston must be completely forward.**

Tools using air source: Air supply should have filter - regulator - lubricator unit with regulator set at 90 psi (620 kPa) - see **WARNING** - cycle tool a few times and disconnect with spindle/rod completely forward.

**CAUTION:** In severe conditions, **VIBRA-TITE** can be used on collet and/or extension threads to prevent loosening or damage. Carefully follow container's directions.

#### 3. Disassembly/assembly as applicable:

Remove parts of nose assembly for inspection and maintenance.

**Collet/extension:** Assemble parts as shown. Spread thin film of SUPER O-LUBE on O-rings and O D of follower. Screw assembled collet onto extension using 9/16 collet wrench, wrench flats or 5/32 - 3/16 - 1/4 hex key - tighten wrench-tight. Screw assembled collet or collet/extension onto spindle/rod. Tighten wrench-tight - see **CAUTION.**

**200 Tool:** Hold spanner wrench, 111239, in slots at rear while snugging-up collet or extension - use collet wrench.

**210/212/230/2400/2702 Tools:** Hold 1/4 (230) or 5/16 hex key (210/2400/2702) in hex at rear while snugging-up collet/extension - use collet wrench.

**Anvil:** Assemble anvil retainer to anvil. Thread correct anvil insert into anvil holder - when changing anvil insert, retaining nut need not be removed.

#### 4. Attaching nose to tool as applicable:

Slide holder/anvil over collet; stop and retaining nut over anvil/holder - tighten hand-tight.

**352 Tool if applicable:** Slide holder/anvil over collet until ear depresses half-moon retainer. Turn holder until locked by retainer - remove shim if ears do not enter groove. On rotatable nose assemblies, hold key, 110237, in anvil slot - as anvil is turned, retainer ears will enter groove.

5. **As applicable:** See **WARNING.** Reconnect controls and **RETURN** hose on hydraulic tool - reconnect hydraulic unit or air tool to power source. Install fasteners in test plate of correct thickness with proper size holes - inspect installed fasteners.

#### Notes:

1. To extend jaw life: Disassemble nose assembly periodically; clean and inspect components - use a pick to clean jaw grooves. **CAUTION:** Wash parts in mineral spirits or isopropyl alcohol only - dry O-rings; urethane jaw assemblies immediately after cleaning as prolonged contact with solvent causes swelling - dry other parts.

2. Spare parts - - as required: Jaws, O-rings, springs, ret. rings, anvil inserts and anvil retainer.

3. Tools/service items - - as required: NYLON bristle brushes - 105805 (04, 05 & 06), 105806 (08) 9/16 collet wrench, 502914; 5/32 hex key, 502450; 3/16 hex key, 502296; 1/4 hex key, 502445 (230) 5/16 hex key, 502446 (2400/2702) adjustable wrench, 503044; spanner wrench, 111239 (200) 0300 TRUARC Pliers, 502858; VIBRA-TITE, 505125; PARKER O-LUBE, 505476.

(352) 200/210/212/230/2400/2702  
W/O lock collars; W or W/O ears  
99-1800 2500; 2600; 3200; 3300; 3400  
in-line series