

# HS-2607

**Eden processor  
Embedded Engine Board**

- CompactFlash • Mini PCI •
- CRT/LVDS • TV-Out • Dual LAN • Audio •
- ATA/33/66/100 • 4 COM • USB2.0 • WDT •

## Copyright Disclaimers

The accuracy of contents in this manual has passed thorough checking and review before publishing. BOSER Technology Co., Ltd., the manufacturer and publisher, is not liable for any infringements of patents or other rights resulting from its use. The manufacturer will not be responsible for any direct, indirect, special, incidental or consequential damages arising from the use of this product or documentation, even if advised of the possibility of such damage(s).

This manual is copyrighted and BOSER Technology Co., Ltd. reserves all documentation rights. Unauthorized reproduction, transmission, translation, and storage of any form and means (i.e., electronic, mechanical, photocopying, recording) of this document, in whole or partly, is prohibited, unless granted permission by BOSER Technology Co., Ltd.

BOSER Technology Co., Ltd. reserves the right to change or improve the contents of this document without due notice. BOSER Technology Co., Ltd. assumes no responsibility for any errors or omissions that may appear in this manual, nor does it make any commitment to update the information contained herein.

## Trademarks

*BOSER is a registered trademark of BOSER Technology Co., Ltd.*

*ISB is a registered trademark of BOSER Technology Co., Ltd.*

*Intel is a registered trademark of Intel Corporation.*

*Award is a registered trademark of Award Software, Inc.*

*AMI is a registered trademark of AMI Software, Inc.*

*All other trademarks, products and or product names mentioned herein are mentioned for identification purposes only, and may be trademarks and/or registered trademarks of their respective companies or owners.*



**© Copyright 2007 BOSER Technology Co., Ltd.  
All Rights Reserved.  
Edition 1.3, December 05, 2007**

## Table of Contents

<b>Chapter 1</b>	<b>General Description .....</b>	<b>1</b>
1.1	Major Features .....	2
1.2	Specifications .....	3
1.3	Board Dimensions .....	4
<b>Chapter 2</b>	<b>Unpacking .....</b>	<b>5</b>
2.1	Opening the Delivery Package .....	5
2.2	Inspection .....	5
<b>Chapter 3</b>	<b>Hardware Installation .....</b>	<b>7</b>
3.1	Before Installation .....	7
3.2	Board Layout .....	8
3.3	Jumper List .....	9
3.4	Connector List .....	9
3.5	Configuring the CPU .....	9
3.6	System Memory .....	10
3.7	CMOS Data Clear .....	10
3.8	Power and Fan Connectors .....	10
3.9	System Front Panel Control .....	11
3.10	VGA Controller .....	11
3.11	TV-Out Connector .....	13
3.12	Ethernet Connector .....	13
3.13	Audio Connectors .....	14
3.14	PCI E-IDE Drive Connector .....	15
3.15	Serial Port Connectors .....	16
3.16	USB Connector .....	16
3.17	Keyboard/Mouse Connectors .....	17
3.18	Mini PCI Slot .....	17
3.19	CompactFlash™ Connector .....	17

<b>Chapter 4</b>	<b>Award BIOS Setup .....</b>	<b>19</b>
4.1	Starting Setup .....	19
4.2	Using Setup .....	20
4.3	Main Menu .....	21
4.4	Standard CMOS Features .....	22
4.5	Advanced BIOS Features .....	23
4.6	Advanced Chipset Features .....	24
4.7	Integrated Peripherals .....	26
4.8	Power Management Setup .....	28
4.9	PnP/PCI Configurations.....	29
4.10	Frequency/Voltage Control .....	30
<b>Chapter 5</b>	<b>Software Utilities .....</b>	<b>31</b>
5.1	VGA Driver Installation .....	31
5.2	LAN Driver Installation.....	41
5.3	Audio Driver Installation.....	51
5.4	USB2.0 Driver Installation .....	57

## Safety Instructions

Integrated circuits on computer boards are sensitive to static electricity. To avoid damaging chips from electrostatic discharge, observe the following precautions:

- Do not remove boards or integrated circuits from their anti-static packaging until you are ready to install them.
- Before handling a board or integrated circuit, touch an unpainted portion of the system unit chassis for a few seconds. This helps to discharge any static electricity on your body.
- Wear a wrist-grounding strap, available from most electronic component stores, when handling boards and components. Fasten the ALLIGATOR clip of the strap to the end of the shielded wire lead from a grounded object. Please wear and connect the strap before handle the product to ensure harmlessly discharge any static electricity through the strap.
- Please use an anti-static pad when putting down any components or parts or tools outside the computer. You may also use an anti-static bag instead of the pad. Please inquire from your local supplier for additional assistance in finding the necessary anti-static gadgets.

**NOTE:** *DO NOT TOUCH THE BOARD OR ANY OTHER SENSITIVE COMPONENTS WITHOUT ALL NECESSARY ANTI-STATIC PROTECTIONS.*



# Chapter 1

## General Description

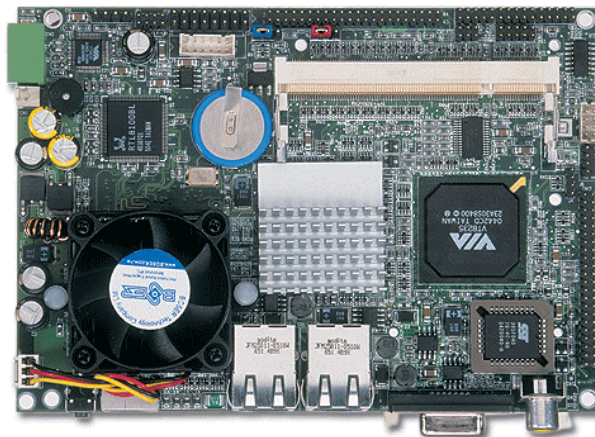

The HS-2607 is a 133MHz FSB VIA CLE266/VT8235 chipset-based board designed for Mini PCI Local Bus VIA Eden 1GHz Embedded CPU. These features combine and make the HS-2607 an ideal all-in-one industrial single board computer. Additional features include an enhanced I/O with CompactFlash reader, CRT/Panel, audio, dual LAN, TV-Out, 4 COM, and USB2.0 interfaces.

Its onboard ATA/33/66/100 to IDE drive interface architecture allows the HS-2607 to support data transfers of 33, 66 or 100MB/sec. To one IDE drive connection. Designed with the VIA CLE266/VT8235 core logic chipset, the board supports VIA Eden 1GHz Embedded CPU. The VIA CLE266 integrated S3 3D supports CRT/Panel displays up to 1600 x 1200 at 32-bit.

HS-2607 offers CompactFlash reader in addition. +7~+26V wide range single DC power in can make HS-2607 suitable for all kinds of environments even more.

System memory is also sufficient with the one 200-pin SO-DDR socket that can supports up to 1GB.

Additional onboard connectors include 4 USB2.0 port providing faster data transmission. And two external RJ-45 connectors for 10/100 Based Ethernet use.

## 1.1 Major Features

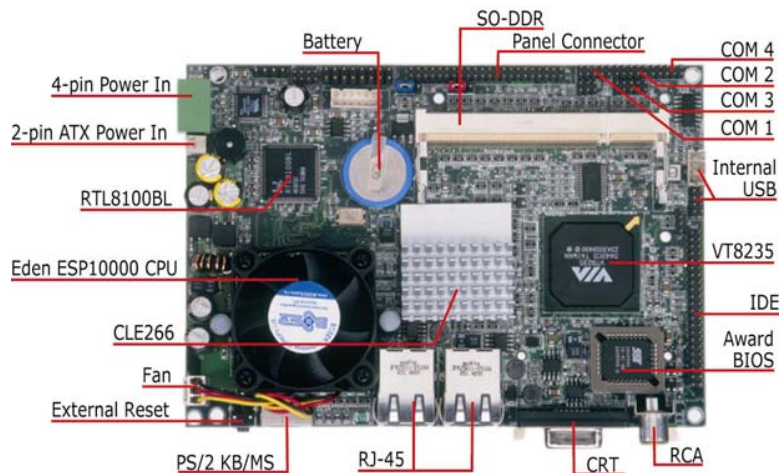

The HS-2607 comes with the following features:

- VIA Eden processor 1GHz
- One SO-DDR socket with a max. capacity of 1GB
- VIA CLE266/VT8235 chipset
- Winbond W83697UF super I/O chipset
- VIA CLE266 graphics controller
- Dual RealTek RTL8100BL Ethernet controller
- AC97 3D audio controller
- Fast PCI ATA/33/66/100 IDE controller
- CF, 4 COM, 4 USB2.0
- +7~+26V wide range single DC power in
- TV-Out function (optional)



## 1.2 Specifications

- **CPU:** VIA Eden processor 1GHz
- **Memory:** One SO-DDR socket supports up to 1GB
- **Chipset:** VIA CLE266/VT8235
- **I/O Chipset:** Winbond W83697UF
- **CompactFlash:** Type I/II IDE interface adapter x 1
- **PCI Slot:** Type I mini PCI slot x 1
- **VGA:** VIA CLE266 integrated S3 3D supports AGP Bus and Hardware MPEG-2
- **TV-Out:** Supports PAL or NTSC TV system (optional)
- **Ethernet:** Dual RealTek RTL8100BL 10/100 Based LAN
- **Audio:** AC97 3D audio controller
- **IDE:** 2.0-pitch 44-pin IDE connector x 1
- **Serial Port:** 16C550 UART-compatible RS-232 x 4 serial ports with 16-byte FIFO
- **USB:** 4 internal USB2.0 ports
- **Keyboard/Mouse:** PS/2 6-pin Mini DIN
- **BIOS:** Award PnP Flash BIOS
- **Watchdog Timer:** Software programmable time-out intervals from 1~255 sec.
- **CMOS:** Battery backup
- **Power In:** +7~+26V wide range single DC power in
- **Temperature:** 0~+60°C (operating)
- **Dimensions:** 14.5(L) x 10.2(W) cm

### 1.3 Board Dimensions

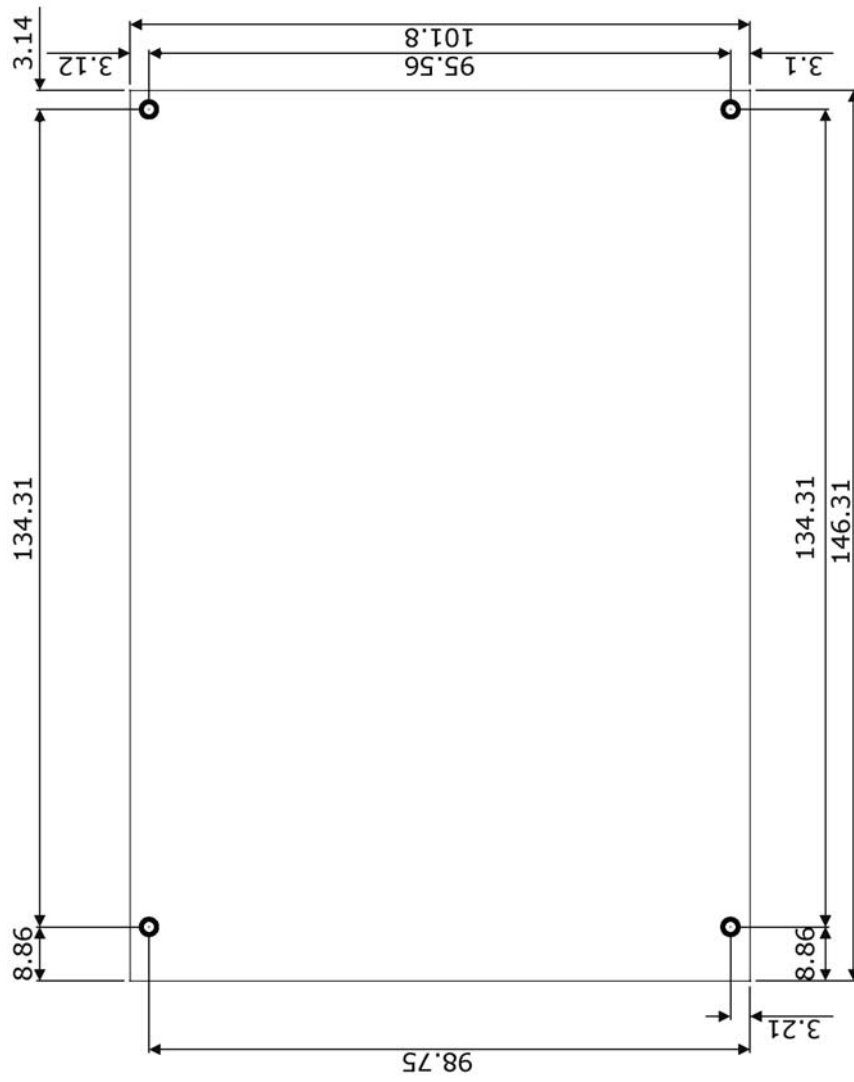

# Chapter 2

---

## Unpacking

### 2.1 Opening the Delivery Package

The HS-2607 is packed in an anti-static bag. The board has components that are easily damaged by static electricity. Do not remove the anti-static wrapping until proper precautions have been taken. Safety instructions in front of this manual describe anti-static precautions and procedures.

### 2.2 Inspection

After unpacking the board, place it on a raised surface and carefully inspect the board for any damage that might have occurred during shipment. Ground the board and exercise extreme care to prevent damage to the board from static electricity.

Integrated circuits will sometimes come out of their sockets during shipment. Examine all integrated circuits, particularly the BIOS, processor, memory modules, ROM-Disk, and keyboard controller chip to ensure that they are firmly seated. The HS-2607 delivery package contains the following items:

- HS-2607 Board x 1
- Utility CD Disk x 1
- Cables Package x 1
- Jumper Bag x 1
- User's Manual



Cables Package	
NO.	Description
1	4-pin power cable x 1
2	MIC/Audio cable x 1
3	8-pin USB split type cable x 1
4	RS-232 cable x 4
5	PS/2 KB/MS transfer cable x 1
6	IDE flat cable x 1

It is recommended that you keep all the parts of the delivery package intact and store them in a safe/dry place for any unforeseen event requiring the return shipment of the product. In case you discover any missing and/or damaged items from the list of items, please contact your dealer immediately.

# Chapter 3

---

## Hardware Installation

This chapter provides the information on how to install the hardware using the HS-2607. This chapter also contains information related to jumper settings of switch, and watchdog timer selection etc.

### 3.1 Before Installation

After confirming your package contents, you are now ready to install your hardware. The following are important reminders and steps to take before you begin with your installation process.

1. Make sure that all jumper settings match their default settings and CMOS setup correctly. Refer to the sections on this chapter for the default settings of each jumper.
2. Go through the connections of all external devices and make sure that they are installed properly and configured correctly within the CMOS setup. Refer to the sections on this chapter for the detailed information on the connectors.
3. Keep the manual and diskette in good condition for future reference and use.

## 3.2 Board Layout

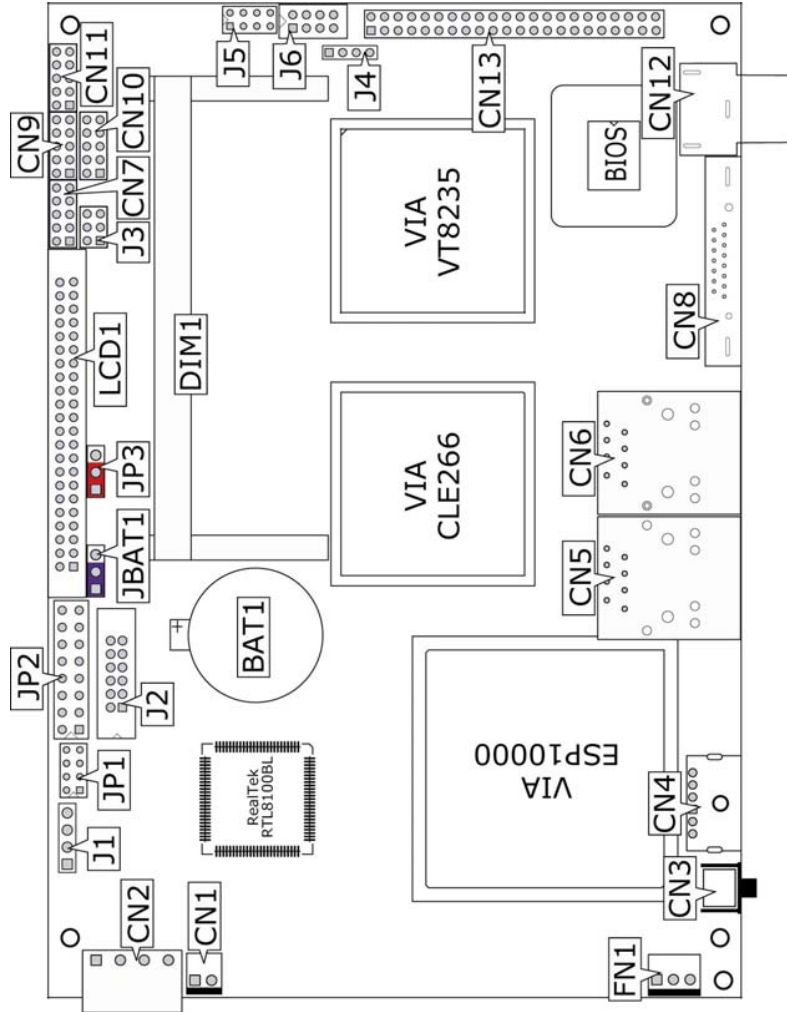

### 3.3 Jumper List

Jumper	Default Setting	Setting	Page
<b>JBAT1</b>	Clear CMOS: <i>Normal Operation</i>	Short 1-2	10
<b>JP3</b>	Panel Voltage Select: +3.3V	Short 1-2	12

### 3.4 Connector List

Connector	Definition	Page
<b>CN1</b>	2-pin ATX Power Control	10
<b>CN2</b>	4-pin DC Power In Connector	10
<b>CN3</b>	External Reset Button	----
<b>CN4</b>	PS/2 6-pin Mini DIN KB/MS Connector	17
<b>CN5/CN6</b>	RJ-45 Connector	14
<b>CN7/CN9/CN10/CN11</b>	COM 1~COM 4 Connector (5x2 header)	16
<b>CN8</b>	15-pin CRT Connector	12
<b>CN12</b>	RCA Connector	13
<b>CN13</b>	IDE Connector	15
<b>CN14</b>	CompactFlash Connector	20
<b>DIM1</b>	SO-DDR Socket	10
<b>FN1</b>	Fan Power In Connector	10
<b>J1</b>	Line In Connector	14
<b>J5/J6</b>	USB Connector	17
<b>JP1</b>	MIC In/Line Out Connector	14
<b>JP2</b>	System Front Panel Control	11
<b>LCD1</b>	LVDS Panel Connector	12
<b>PC1</b>	Mini PCI Connector	18

### 3.5 Configuring the CPU

The HS-2607 embedded with a VIA Eden ESP10000 1GHz embedded CPU, user don't need to adjust the frequently and check speed of the CPU.

The new VIA Eden ESP10000 processors based on the Nehemiah core build on the VIA Eden platform lineup, enabling improved digital media performance with ultra low power consumption.

## 3.6 System Memory

The HS-2607 provides one 200-pin SO-DDR socket at locations *DIM1*. The maximum capacity of the onboard memory is 512MB.

## 3.7 CMOS Data Clear

The HS-2607 has a Clear CMOS jumper on *JBAT1*.

- **JBAT1: Clear CMOS**

Options	Settings
Normal Operation (default)	Short 1-2
Clear CMOS	Short 2-3



**IMPORTANT:** Before you turn on the power of your system, please set *JBAT1* to Short 1-2 for normal operation.

## 3.8 Power and Fan Connectors

HS-2607 provides one 4-pin power connector at *CN2*. And one 2-pin ATX power in at *CN1*. Connector *FN1* onboard HS-2607 is a 3-pin fan power output connector. And HS-2607 supports +5V fan only.

- **CN1: 2-pin ATX Power Control**

PIN	Description
1	PS_ON
2	5VSB



- **CN14: 4-pin DC Power In Connector**

PIN	Description
1	+7~+26V
2	GND
3	GND
4	+7~+26V



- **FN1: Fan Power In Connector**

PIN	Description
1	GND
2	+5V
3	N/C

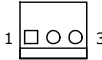



### 3.9 System Front Panel Control

The HS-2607 has system front panel control at location *JP2*.

- **JP2: System Front Panel Control**

PIN	Description	PIN	Description
1	VCC	2	330Ω Pull +5V
3	GND	4	GND
5	N/C	6	LAN Link LED
7	Speaker	8	GND
9	GND	10	PW Button
11	Reset Switch	12	GND
13	330Ω Pull +5V	14	LAN TX/RX LED
15	HDD LED	2+	GND

#### Connector JP2 Orientation

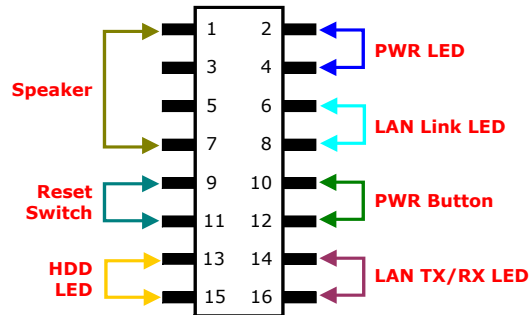

### 3.10 VGA Controller

The HS-2607 provides two connection methods of a VGX device. *CN8* offers a single standard CRT connector while *LCD1* is the 44-pin panel connector. VIA CLE266 VGA chipset shared main memory 8/16/32MB, and provides high quality DVD video playback. HS-2607 also provides Hardware MPEG-2.

● **CN8: 15-pin CRT Connector**

PIN	Description	PIN	Description
1	Red	2	Green
3	Blue	4	N/C
5	GND	6	GND
7	GND	8	GND
9	N/C	10	GND
11	N/C	12	SDA
13	HSYNC	14	VSYNC
15	SCL		

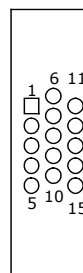

● **LCD1: 44-pin Panel Connector**

PIN	Description	PIN	Description
1	N/C	2	N/C
3	GND	4	GND
5	V <sub>LCD</sub>	6	ENAVDD
7	ENAVEE	8	GND
9	GFPD0	10	GFPD1
11	GFPD2	12	GFPD3
13	GFPD4	14	GFPD5
15	GFPD6	16	GFPD7
17	GFPD8	18	GFPD9
19	GFPD10	20	GFPD11
21	GFPD12	22	GFPD13
23	GFPD14	24	GFPD15
25	GFPD16	26	GFPD17
27	GFPD18	28	GFPD19
29	GFPD20	30	GFPD21
31	GFPD22	32	GFPD23
33	N/C	34	N/C
35	SHFLCK	36	GFPVS
37	GFPDEN	38	GHPHS
39	GND	40	FPBKLP
41	N/C	42	N/C
43	N/C	44	N/C

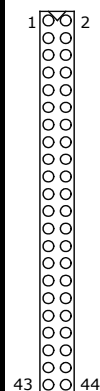

**NOTE:** Please set the proper voltage of your panel use JP3 before proceeding on installing it.

The HS-2607 has an onboard jumper that selects the working voltage of the flat panel connected to the system. Jumper *JP3* offers two voltages setting for the user.

- **JP3: Panel Voltage Select**

Options	Settings
<b>+3.3V (default)</b>	Short 1-2
<b>+5V</b>	Short 2-3



### 3.11 TV-Out Connector

The HS-2607 can supports TV-Out function which input could be up to 800 x 600 graphics resolutions. World Wide Video standards are supported including NTSC-M (North America, Taiwan), NTSC-J (Japan), PAL-B, D, G, H, I (Europe Asia), PAL-M (Brazil), PAL-N (Uruguay, Paraguay) and PAL-NC (Argentina).

- **CN12: RCA Connector (for TV-Out function)**

PIN	Description
<b>1</b>	SPDIFO
<b>2</b>	GND
<b>3</b>	GND
<b>4</b>	GND

### 3.12 Ethernet Connector

The HS-2607 provides two external RJ-45 interface connectors. Please refer to the following for its pin information.

- **CN5/CN6: RJ-45 Connector**

PIN	Description
<b>1</b>	TX+
<b>2</b>	TX-
<b>3</b>	RX+
<b>4</b>	R/C GND
<b>5</b>	R/C GND
<b>6</b>	RX-
<b>7</b>	R/C GND
<b>8</b>	R/C GND

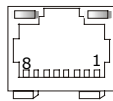

### 3.13 Audio Connectors

The HS-2607 has an onboard AC97 3D audio controller. The following tables list the pin assignments of the Line In/Audio Out connector.

- **JP1: MIC In/Audio Out Connector**

PIN	Description	PIN	Description
1	AOUTL	2	AOUTR
3	GND	4	GND
5	MIC IN	6	N/C
7	GND	8	GND



- **J1: Line In Connector**

PIN	Description	PIN	Description
1	LINE R	2	GND
3	GND	4	LINE L



### 3.14 PCI E-IDE Drive Connector

CN12 is a standard 44-pin 2.0-pitch connector daisy-chain driver connector serves the PCI E-IDE drive provisions onboard the HS-2607. A maximum of two ATA/33/66/100 IDE drives can be connected to the HS-2607 via CN13.

- **CN13: IDE Connector**

PIN	Description	PIN	Description
1	Reset	2	GND
3	DATA 7	4	DATA 8
5	DATA 6	6	DATA 9
7	DATA 5	8	DATA 10
9	DATA 4	10	DATA 11
11	DATA 3	12	DATA 12
13	DATA 2	14	DATA 13
15	DATA 1	16	DATA 14
17	DATA 0	18	DATA 15
19	GND	20	N/C
21	PDREQ	22	GND
23	IOW#	24	GND
25	IOR#	26	GND
27	PIORDY	28	GND
29	RPDACK-	30	GND
31	Interrupt	32	N/C
33	RPDA1-	34	PATA66
35	RPDA0-	36	RPDA2-
37	RPCS1-	38	RPCS3-
39	HDD Active	40	GND
41	VCC	42	VCC
43	GND	44	N/C

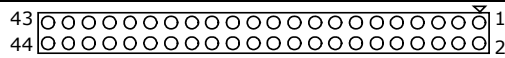

### 3.15 Serial Port Connectors

The HS-2607 offers NS16C550 compatible UARTs with Read/Receive 16-byte FIFO serial ports and internal 10-pin headers.

- **CN7/CN9~CN11: COM 1~COM 4 Connector (5x2 Header)**

PIN	Description	PIN	Description
1	DCD	2	DSR
3	RXD	4	RTX
5	TXD	6	CTX
7	DTR	8	RI
9	GND	10	N/C



### 3.16 USB Connector

The HS-2607 provides two 8-pin connectors, at location J5 and J6, for four USB2.0 ports to the HS-2607.

- **J5/J6: USB2.0 Connector**

PIN	Description	PIN	Description
1	VCC	2	VCC
3	BD2-/ BD0-	4	BD3-/BD1-
5	BD2+/ BD0+	6	BD3+/BD1+
7	GND	8	GND

### 3.17 Keyboard/Mouse Connectors

The connection via CN4 for an external PS/2 type KB/MS.

- **CN4: PS/2 6-pin Mini DIN KB/MS Connector**

PIN	Description
1	Keyboard Data
2	Mouse Data
3	GND
4	+5V
5	Keyboard Clock
6	Mouse Clock

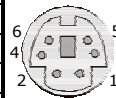

### 3.18 Mini PCI Slot

HS-2607 supports a mini PCI connector. The peripheral component with standard Typel mini PCI can be used. For particular requirement, please refer to “BOSER Mini PCI Series” product on website or contact with us.

### 3.19 CompactFlash™ Connector

The HS-2607 also offers a Type I/II CompactFlash™ connector which is IDE interface located at the solder side of the board (beneath the SO-DIMM connector). The designated CN14 connector, once soldered with an adapter, can hold CompactFlash™ cards of various sizes. Please turn off the power before inserting the CF card.

Inserting a CompactFlash™ card into the adapter is not a difficult task. The socket and card are both keyed and there is only one direction for the card to be completely inserted. Refer to the diagram on the following page for the traditional way of inserting the card.

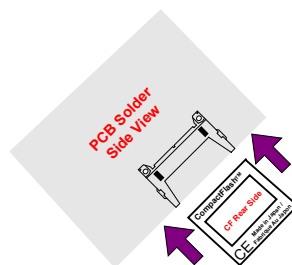

**This page is the blank page.**



# Chapter 4

---

## Award BIOS Setup

The HS-2607 uses Award BIOS for the system configuration. The Award BIOS setup program is designed to provide the maximum flexibility in configuring the system by offering various options that could be selected for end-user requirements. This chapter is written to assist you in the proper usage of these features.

### 4.1 Starting Setup

The Award BIOS is immediately activated when you first power on the computer. The BIOS reads the system information contained in the CMOS and begins the process of checking out the system and configuring it. When it finishes, the BIOS will seek an operating system on one of the disks and then launch and turn control over to the operating system.

While the BIOS is in control, the Setup program can be activated in one of two ways:

1. By pressing <Del> immediately after switching the system on, or
2. By pressing the <Del> key when the following message appears briefly at the bottom of the screen during the POST (Power On Self Test).





**Press DEL to enter SETUP.**

If the message disappears before you respond and you still wish to enter Setup, restart the system to try again by turning it OFF then ON or pressing the "RESET" button on the system case. You may also restart by simultaneously pressing <Ctrl>, <Alt>, and <Delete> keys. If you do not press the keys at the correct time and the system does not boot, an error message will be displayed and you will be asked to...

**PRESS F1 TO CONTINUE, DEL TO ENTER SETUP**

## 4.2 Using Setup

In general, you use the arrow keys to highlight items, press <Enter> to select, use the <PageUp> and <PageDown> keys to change entries, and press <Esc> to quit. The following table provides more detail about how to navigate in the Setup program using the keyboard.

	Move to previous item
	Move to next item
	Move to previous item
	Move to previous item
<b>Esc key</b>	Main Menu -- Quit and not save changes into CMOS Status Page Setup Menu and Option Page Setup Menu -- Exit current page and return to Main Menu
<b>PgUp key</b>	Decrease the numeric value or make changes
<b>PgDn key</b>	Increase the numeric value or make changes
<b>+ key</b>	Increase the numeric value or make changes
<b>- key</b>	Decrease the numeric value or make changes
<b>F1 key</b>	Reserved
<b>F2 key</b>	Change color from total 8 colors. F2 to select color forward
<b>F3 key</b>	F2 to select color backward
<b>F4 key</b>	Reserved
<b>F5 key</b>	Reserved
<b>F6 key</b>	Reserved
<b>F7 key</b>	Reserved
<b>F8 key</b>	Reserved
<b>F9 key</b>	Reserved
<b>F10 key</b>	Save all the CMOS changes, only for Main Menu

### 4.3 Main Menu

Once you enter the Award BIOS CMOS Setup Utility, the Main Menu will appear on the screen. The Main Menu allows you to select from several setup functions and two exit choices. Use the arrow keys to select among the items and press <Enter> to enter the sub-menu.

▶ Standard CMOS Features	Load Fail-Safe Defaults
▶ Advanced BIOS Features	Load Optimized Defaults
▶ Advanced Chipset Features	Set Supervisor Password
▶ Integrated Peripherals	Set User Password
▶ Power Management Setup	Save & Exit Setup
▶ PnP/PCI Configurations	Exit Without Saving
▶ Frequency/Voltage Control	
Esc: Quit                      F9: Menu in BIOS                      ↑ ↓ ← →: Select Item	
F10: Save & Exit Setup	

**NOTE:** *A brief description of the highlighted choice appears at the bottom of the screen.*

## 4.4 Standard CMOS Features

The standard CMOS is used for the basic hardware system configuration. The main function is for Data/Time and Floppy/Hard Disk Drive settings. Please refer to the following screen for the setup. When the IDE hard disk drive you are using is larger than 528MB, you must set the HDD mode to LBA mode. Please use the IDE setup utility in BIOS setup to install the HDD correctly.

Phoenix – AwardBIOS CMOS Setup Utility  
Standard CMOS Features

Date (mm:dd:yy)	Mon, Aug 9 2004	Item Help
Time (hh:mm:ss)	10 : 32 : 57	
▶ IDE Primary Master	[Auto]	
▶ IDE Primary Slave	[Auto]	
▶ IDE Secondary Master	[Auto]	
▶ IDE Secondary Slave	[Auto]	
Video	[EGA/VGA]	
Halt On	[All, But Keyboard]	
Base Memory	640K	
Extended Memory	56320K	
Total Memory	57344K	
↑ ↓ ← →: Select Item    +/-/PU/PD: Value    F10: Save    Esc: Quit    F1: General Help		
F5: Previous Values    F6: Fail-Safe Defaults    F7: Optimized Defaults		

## 4.5 Advanced BIOS Features

This section allows you to configure your system for the basic operation. You have the opportunity to select the system's default speed, boot-up sequence, keyboard operation, shadowing and security.

### Phoenix – AwardBIOS CMOS Setup Utility Advanced CMOS Features

Virus Warning	[Disabled]	Item Help
CPU Internal Cache	[Enabled]	
External Cache	[Enabled]	
CPU L2 Cache ECC Checking	[Enabled]	
Quick Power On Self Test	[Enabled]	
First Boot Device	[HDD-0]	
Second Boot Device	[CDROM]	
Third Boot Device	[HDD-1]	
Boot Other Device	[Enabled]	
Boot Up NumLock Status	[On]	
Gate A20 Option	[Fast]	
Typematic Rate Setting	[Disabled]	
Typematic Rate (Chars/Sec)	6	
Typematic Delay (Msec)	250	
Security Option	[Setup]	
MPS Version Control For OS	[1.4]	
OS Select For DRAM > 64MB	[Non-OS2]	
Video BIOS Shadow	[Enabled]	
Small Logo(EPA) Show	[Enabled]	
↑ ↓ ← →: Select Item    +/-/PU/PD: Value    F10: Save    Esc: Quit    F1: General Help F5: Previous Values    F6: Fail-Safe Defaults    F7: Optimized Defaults		

## 4.6 Advanced Chipset Features

This section allows you to configure the system based on the specific features of the installed chipset. This chipset manages bus speeds and the access to the system memory resources, such as DRAM and the external cache. It also coordinates the communications between the conventional ISA and PCI buses. It must be stated that these items should never be altered. The default settings have been chosen because they provide the best operating conditions for your system. You must consider making any changes only if you discover that the data has been lost while using your system.

### Phoenix – AwardBIOS CMOS Setup Utility Advanced Chipset Features

DRAM Click/Drive Control	[Press Enter]	Item Help	
AGP & P2P Bridge Control	[Press Enter]		
CPU & PCI Bus Control	[Press Enter]		
Memory Hole	[Disabled]		
System BIOS Cacheable	[Enabled]		
Video RAM Cacheable	[Enabled]		
VGA Share Memory Size	[32M]		
Select Display Device	[CRT]		
TV_type	[NTSC]		
TV_Connector	[Auto Mode]		
TV_Layout	[Default]		
Panel Type	[00]		
↑ ↓ ← →: Select Item    +/-/PU/PD: Value    F10: Save    Esc: Quit    F1: General Help			
F5: Previous Values    F6: Fail-Safe Defaults    F7: Optimized Defaults			

### Phoenix – AwardBIOS CMOS Setup Utility DRAM Clock/Drive Control

Current FSB Frequency	133MHz	Item Help
Current DRAM Frequency	133MHz	
DRAM Clock	[By PSD]	
DRAM Timing	[By PSD]	
DRAM CAS Latency	2.5	
Bank Inter leave	Disabled	
Precharge to Active (Trp)	3T	
Active to Precharge (Tras)	6T	
Active to CMD (Tred)	3T	
DRAM Command Rate	[2T Command]	
↑ ↓ ← →: Select Item    +/-/PU/PD: Value    F10: Save    Esc: Quit    F1: General Help		
F5: Previous Values    F6: Fail-Safe Defaults    F7: Optimized Defaults		

Phoenix – AwardBIOS CMOS Setup Utility  
AGP & P2P Bridge Control

AGP Aperture Size                    [64M] AGP Mode                                [4X] AGP Driving Control                    [Auto] AGP Driving Value                      DA AGP Fast Write                          [Disabled] AGP Master 1 WS Write                [Disabled] AGP Master 1 WS Read                [Disabled]	Item Help
↑ ↓ ← →: Select Item    +/-/PU/PD: Value    F10: Save    Esc: Quit    F1: General Help F5: Previous Values                  F6: Fail-Safe Defaults                  F7: Optimized Defaults	

Phoenix – AwardBIOS CMOS Setup Utility  
CPU & PCI Bus Control

CPU to PCI Write Buffer                [Enabled] PCI Master 0 WS Write                [Enabled] PCI Delay Transaction                [Disabled]	Item Help
↑ ↓ ← →: Select Item    +/-/PU/PD: Value    F10: Save    Esc: Quit    F1: General Help F5: Previous Values                  F6: Fail-Safe Defaults                  F7: Optimized Defaults	

## 4.7 Integrated Peripherals

Phoenix – AwardBIOS CMOS Setup Utility

### Integrated Peripherals

VIA OnChip IDE Device	[Press Enter]	Item Help
VIA OnChip PCI Device	[Press Enter]	
Super IO Device	[Press Enter]	
GPIO Pin 8-11 I/O Program	[Input]	
GPO 8 High/Low State	Low	
GPO 9 High/Low State	Low	
GPO 10 High/Low State	Low	
GPO 11 High/Low State	Low	
Init Display First	[PCI Slot]	
Onboard Serial Port 3	[3E8]	
Serial Port 3 Use IRQ	[IRQ10]	
Onboard Serial Port 4	[2E8]	
Serial Port 4 Use IRQ	[IRQ11]	
↑ ↓ ← →: Select Item    +/-/PU/PD: Value    F10: Save    Esc: Quit    F1: General Help		
F5: Previous Values    F6: Fail-Safe Defaults    F7: Optimized Defaults		

Phoenix – AwardBIOS CMOS Setup Utility

### VIA OnChip IDE Device

OnChip IDE Channel0	[Enabled]	Item Help
OnChip IDE Channel1	[Enabled]	
IDE Prefetch Mode	[Enabled]	
Primary Master PIO	[Auto]	
Primary Slave PIO	[Auto]	
Secondary Master PIO	[Auto]	
Secondary Slave PIO	[Auto]	
Primary Master UDMA	[Auto]	
Primary Slave UDMA	[Auto]	
Secondary Master UDMA	[Auto]	
Secondary Slave UDMA	[Auto]	
IDE HDD Block Mode	[Enabled]	
↑ ↓ ← →: Select Item    +/-/PU/PD: Value    F10: Save    Esc: Quit    F1: General Help		
F5: Previous Values    F6: Fail-Safe Defaults    F7: Optimized Defaults		



Phoenix – AwardBIOS CMOS Setup Utility  
VIA OnChip PCI Device

VIA-3058 AC97 Audio	[Auto]	Item Help
OnChip USB Controller	[All Enabled]	
OnChip EHCI Controller	[Enabled]	
USB Keyboard Support	[Enabled]	
USB Mouse Support	[Disabled]	
↑ ↓ ← →: Select Item    +/-/PU/PD: Value    F10: Save    Esc: Quit    F1: General Help		
F5: Previous Values    F6: Fail-Safe Defaults    F7: Optimized Defaults		

Phoenix – AwardBIOS CMOS Setup Utility  
Super IO Device

Onboard Serial Port 1	[3F8/IRQ4]	Item Help
Onboard Serial Port 2	[2F8/IRQ3]	
UART Mode Select	[Normal]	
RxD , TxD Active	[Hi,Lo]	
IR Transmission Delay	[Enabled]	
UR2 Duplex Mode	[Half]	
Use IR Pins	[IR-Rx2Tx2]	
Midi Port Address	[330]	
Midi Port IRQ	5	
↑ ↓ ← →: Select Item    +/-/PU/PD: Value    F10: Save    Esc: Quit    F1: General Help		
F5: Previous Values    F6: Fail-Safe Defaults    F7: Optimized Defaults		

## 4.8 Power Management Setup

The power management setup allows user to configure the system for saving energy in a most effective way while operating in a manner consistent with his owns style of computer use.

### Phoenix – AwardBIOS CMOS Setup Utility Power Management Setup

ACPI function	[Enabled]	Item Help
ACPI Suspend Type	[S1(POS)]	
Power Management Option	[User Define]	
HDD Power Down	[Disabled]	
Suspend Mode	[Disabled]	
Video Off Option	[Suspend → Off]	
Video Off Method	[V/H SYNC+Blank]	
MODEM Use IRQ	[3]	
Soft-off by PWRBTN	[Instant-off]	
Run VGABIOS if S3 Resume	[Auto]	
IRQ/Event Activity Detect	[Press Enter]	
↑ ↓ ← →: Select Item    +/-/PU/PD: Value    F10: Save    Esc: Quit    F1: General Help		
F5: Previous Values    F6: Fail-Safe Defaults    F7: Optimized Defaults		

### Phoenix – AwardBIOS CMOS Setup Utility IRQ/Event Activity Detect

PS2KB Wakeup Select	[Hot Key]	Item Help
PS2KB Wakeup from S3/S4/S5	[Disabled]	
Power Button Lock	Enabled	
PS2MS Wakeup from S3/S4/S5	[Disabled]	
USB Resume from S3	[Disabled]	
VGA	[OFF]	
LPT & COM	[LPT/COM]	
HDD & FDD	[ON]	
PCI Master	[OFF]	
PowerOn By PCI Card	[Disabled]	
Modem Ring Resume	[Disabled]	
RTC Alarm Resume	[Disabled]	
Date (of Month)	0	
Resume Time (hh:mm:ss)	0:0:0	
IRQs Activity Monitoring	[Press Enter]	
↑ ↓ ← →: Select Item    +/-/PU/PD: Value    F10: Save    Esc: Quit    F1: General Help		
F5: Previous Values    F6: Fail-Safe Defaults    F7: Optimized Defaults		

Phoenix – AwardBIOS CMOS Setup Utility  
IRQs Activity Monitoring

Primary INTR	[ON]	Item Help
IRQ3 (COM 2)	[Enabled]	
IRQ4 (COM 1)	[Enabled]	
IRQ5 (LPT 2)	[Enabled]	
IRQ6 (Floppy Disk)	[Enabled]	
IRQ7 (LPT 1)	[Enabled]	
IRQ8 (RTC Alarm)	[Disabled]	
IRQ9 (IRQ2 Redir)	[Disabled]	
IRQ10 (Reserved)	[Disabled]	
IRQ11 (Reserved)	[Disabled]	
IRQ12 (PS/2 Mouse)	[Enabled]	
IRQ13 (Coprocessor)	[Enabled]	
IRQ14 (Hard Disk)	[Enabled]	
IRQ15 (Reserved)	[Disabled]	
↑ ↓ ← →: Select Item    +/-/PU/PD: Value    F10: Save    Esc: Quit    F1: General Help F5: Previous Values    F6: Fail-Safe Defaults    F7: Optimized Defaults		

## 4.9 PnP/PCI Configurations

This section describes the configuration of the PCI bus system. Peripheral Components Interconnect (PCI), is a system that allows I/O devices to operate at speeds nearing the speed the CPU itself uses when communicating with its own special components. This section covers some very technical items and it is strongly recommended that only experienced users should make any changes to the default settings.

Phoenix – AwardBIOS CMOS Setup Utility  
PnP/PCI Configurations

PNP OS Installed	[No]	Item Help	
Reset Configuration Data	[Disabled]		
Resources Controlled By	[Auto(ESCD)]		
IRQ Resources	Press Enter		
PCI/VGA Palette Snoop	[Disabled]		
Assign IRQ For VGA	[Enabled]		
Assign IRQ For USB	[Enabled]		
↑ ↓ ← →: Select Item    +/-/PU/PD: Value    F10: Save    Esc: Quit    F1: General Help F5: Previous Values    F6: Fail-Safe Defaults    F7: Optimized Defaults			

## 4.10 Frequency/Voltage Control

Phoenix - AwardBIOS CMOS Setup Utility  
Frequency/Voltage Control

VIA C3 Clock Ratio	[Default]	Item Help
Auto Detect DIMM/PCI Clk	[Enabled]	
Spread Specturm	[Disabled]	
CPU Host/PCI Clock	[Default]	
↑ ↓ ← →: Select Item    +/-/PU/PD: Value    F10: Save    Esc: Quit    F1: General Help		
F5: Previous Values    F6: Fail-Safe Defaults    F7: Optimized Defaults		

# Chapter 5

## Software Utilities

The chapter contains the detailed information of VGA, LAN, audio, and USB2.0 driver installation procedures.

The drivers are located in the following directories of the utility disk:

- ◆ **VGA Driver:** \VGA\WIN98\_ME or \VGA\XP\_2K
- ◆ **LAN Driver:** \LAN
- ◆ **Audio Driver:** \AC97
- ◆ **USB2.0 Driver:** \USB20\2K or \USB\XP

### 5.1 VGA Driver Installation

#### 5.1.1 WIN95/98

1. With the Utility CD Disk still in your CD-ROM drive, open the File Manager and then select the VGA driver folder.

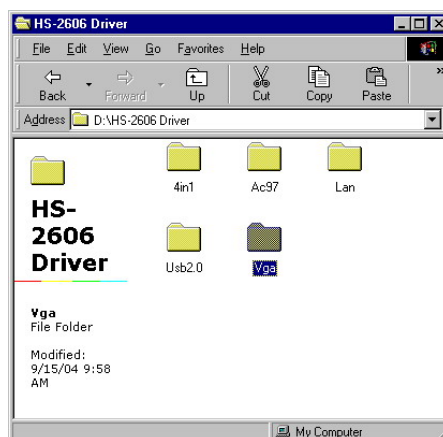

2. Select the operation system of your computer to proceed with the installation process.

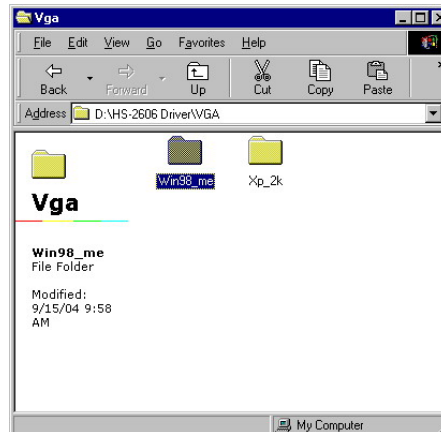

3. Click on the "Setup.exe" and to go setup.



4. Once the Welcome screen appears on the screen, make sure to close applications that are running and then click the **Next>** button.



5. When the display below appears on your screen, Setup is already ready to install and copy the related files onto your hard drive. Click on the Next button to proceed.

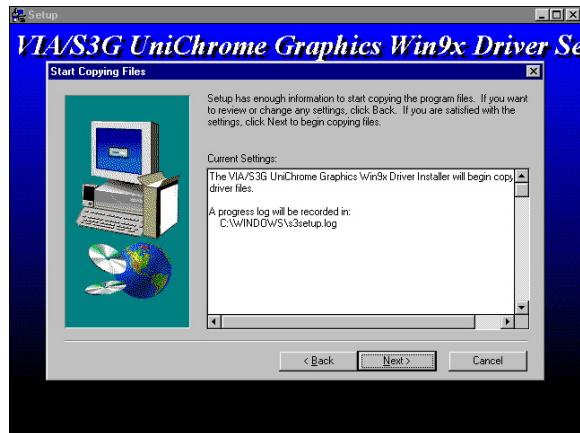

6. After the installation finishes, you will be prompted to restart your system. We recommend you to reboot your computer to allow the new settings to take effect. Click on the Finish button to reboot.



### 5.1.2 VGA Driver Installation for WIN2K/XP

**NOTE:** Please make sure you have already installed *Service Pack 6.0*.

1. With the Utility CD Disk still in your CD ROM drive, open the File Manager and then select the VGA driver folder.

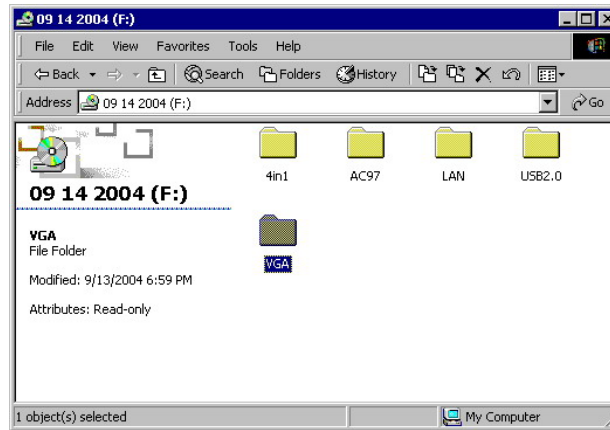



2. Select the operating system of your computer to proceed with the installation process.

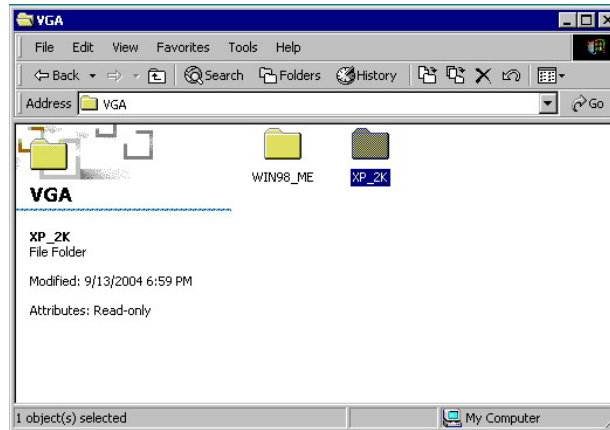

3. Click on the "Setup.exe" and to go setup.

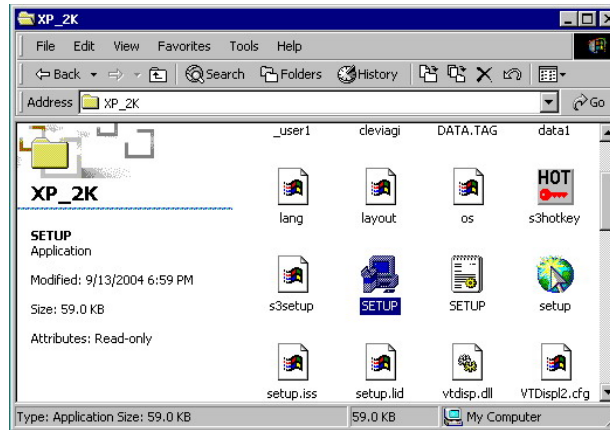

4. Once the Welcome screen appears on the screen, make sure to close applications that are running and then click the Next button.

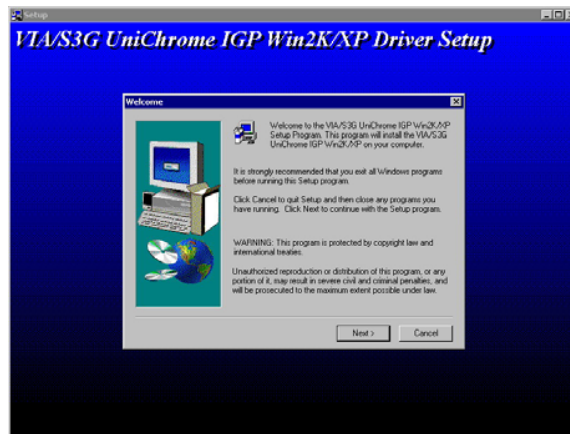

5. When the display below appears on your screen, Setup is already ready to install and copy the related files onto your hard drive. Click on the Next button to proceed.

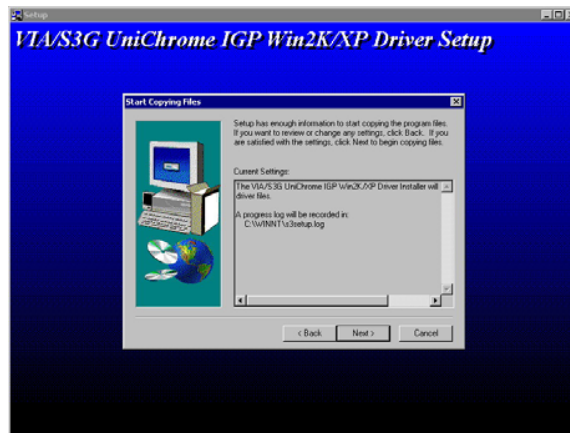

6. After the installation finishes, you will be prompted to restart your system. We recommend you to reboot your computer to allow the new settings to take effect. Click on the **Finish** button to reboot.

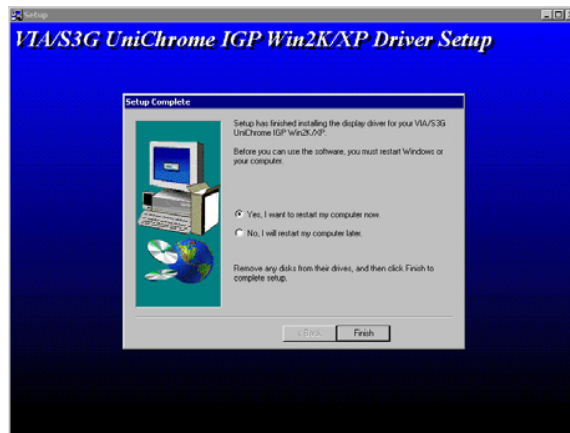

### 5.1.3 VGA Driver Installation for WIN NT4.0

1. Click the **Start** button on the lower left hand corner of your screen, then select **Setting**. Choose **Control Panel** and double-click on the **Display** icon to launch its **Display Properties** window.

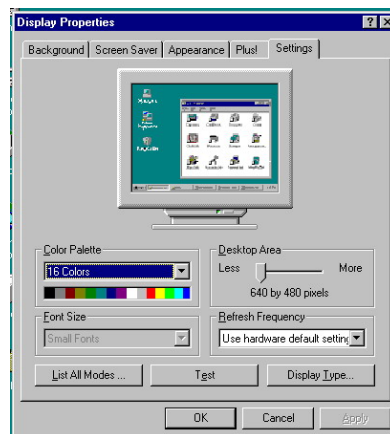

2. Click on the **Settings** tab, and then choose **Display Type**.

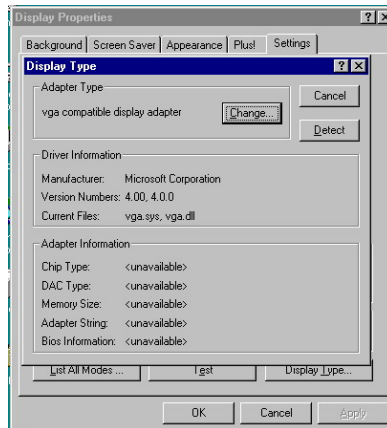

3. In the **Change Display Type** window, click on **Have Disk**.

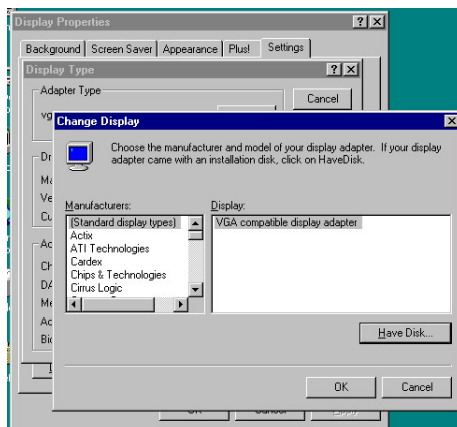

4. Specify the path of the new driver and then press on **Enter**. (If in driver E:, type E:\Vga\WinNT)

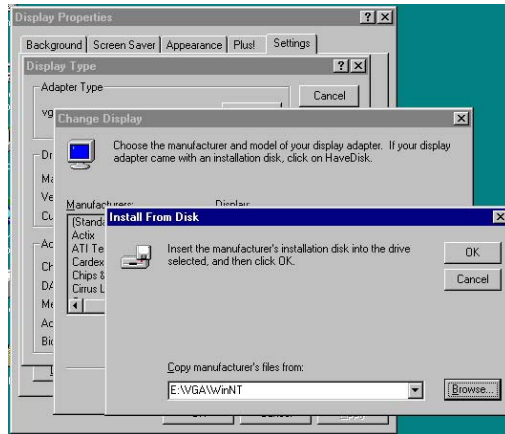

5. Select VIA/S3G UniChrome Graphics, then click OK or press Enter.

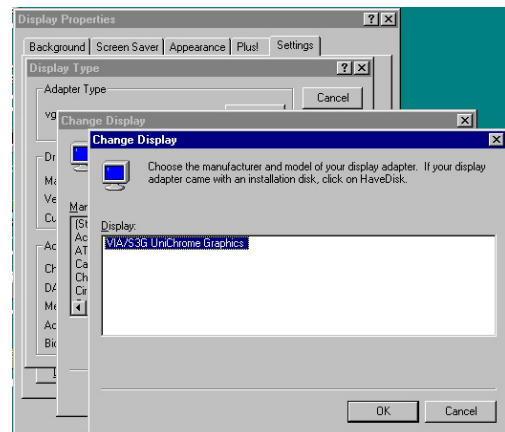

6. You will see warning panel about **Third Party Drivers**. Click on **Yes** to finish the installation.

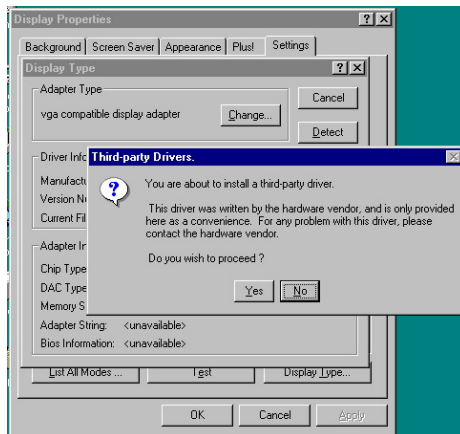

7. Once the installation is completed, you must shut down the system and restart for the new driver to take effect.

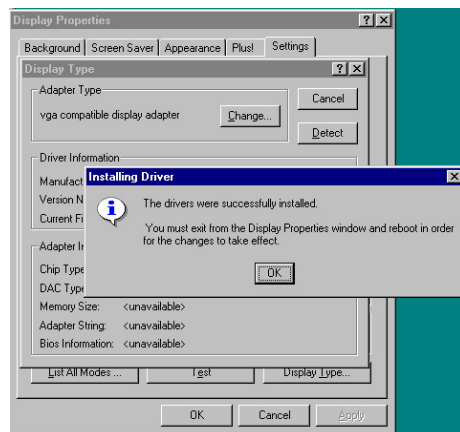

8. Press on the **OK** button as soon as you have located the path of your driver.

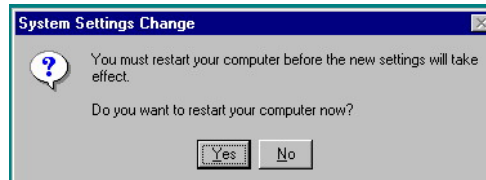

## 5.2 LAN Driver Installation

### 5.2.1 LAN Driver Installation for WIN95/98/2K

1. With the Utility CD Disk still in your CD ROM drive, right click on My Computer icon from the Windows menu. Select on System Properties and then proceed to the Device Manager from the main menu.

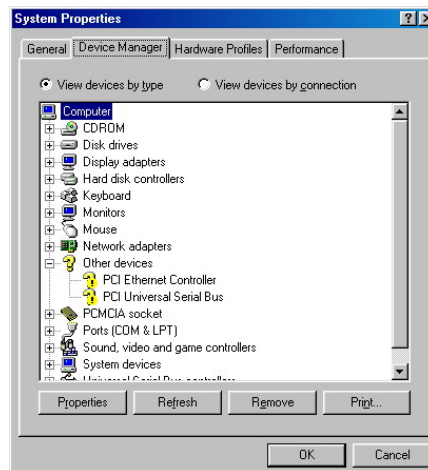
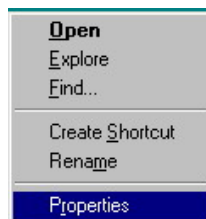

2. Select on PCI Ethernet Controller from Other devices list, right-click and then select on Properties.

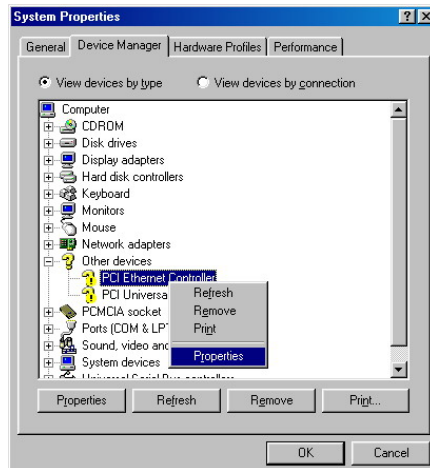

3. The PCI Ethernet Controller Properties screen then appears, allowing you to reinstall the driver. Select Driver from the main menu to proceed.





- The window then displays the current status of your LAN driver. Press on Update Driver button to continue.
- The program will then launch the Update Device Driver Wizard window that will install your device driver. Click on the Next button to proceed to the next step.

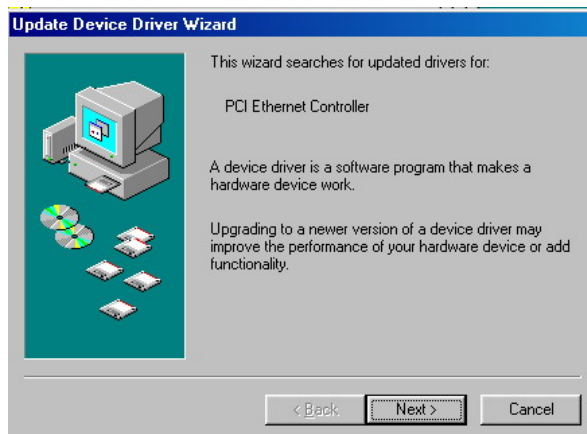

- The Update Device Driver Wizard will then ask you to specify, by ticking, the path of the new driver. Tick on the open boxes where you require the program to search for the device driver then click on the Browse button to manually specify the path. (If in E:, type E:\HS-2607 Driver\LAN\w/in98)
- Update Device Driver Wizard will ask are you sure to updated driver, tick on update, and then press Next to continue.



8. Once the program detects the device driver (\*.inf) file from your specified location, it will automatically copy the files into your hard drive.



9. The program then copies the necessary files from your Windows installation disk to complete the driver setup process. Once the driver is completely installed, the following message appears on your display. Click on the Finish button to proceed.

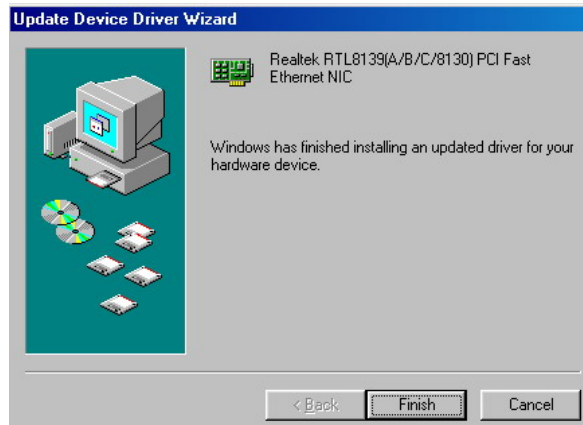

- Restart your computer to make the new system settings take effect. Click on the Yes button when the screen below appears and your LAN Driver for Win95 and Win98 are now completely installed.

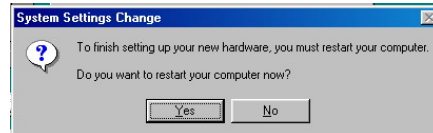

### 5.2.2 LAN Driver Installation for WIN NT4.0

- With the Utility CD Disk still in your CD ROM drive, right click on Network Neighborhood icon from the Windows menu. Select on Properties.

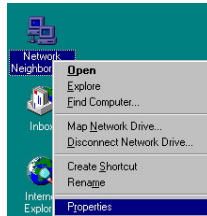

- The system automatically detects the absence of Windows NT Networking. Click on the Yes button to start installation.

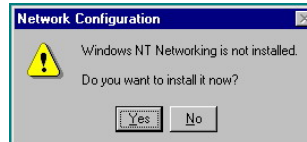

3. Tick on the "Wired to Network" once the following screen appears. Click on the Next to proceed.

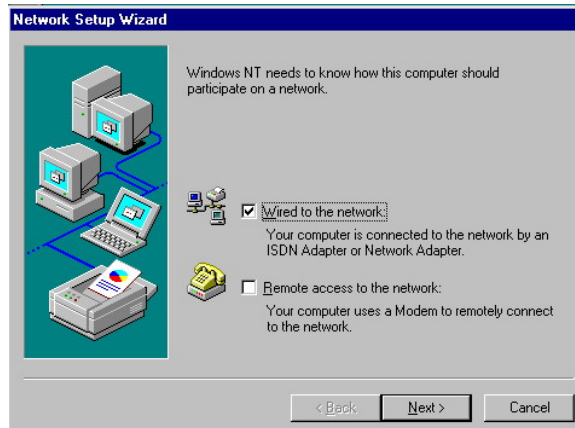

4. Click on the Start Search button for the program to locate the Network Adapter.



5. Once setup finishes the search, it will list a number of adapters for you to choose from. Press on the Have Disk button to assign the driver path location.

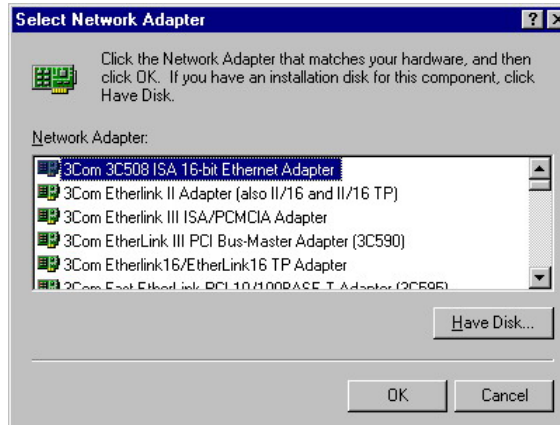

6. Setup now asks you for the location of the driver. When you have entered the new driver path, press on the OK button to continue.

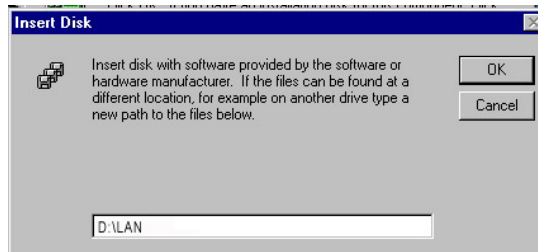

7. When Setup finds the information it needs about the new driver, it will display the device it found on the following screen. Press on the OK button to accept and proceed.

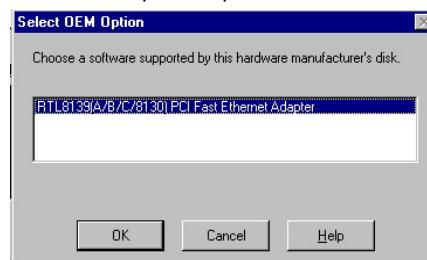

8. Setup then returns to Network Setup Wizard screen and displays your new Network Adapter. Click on Next to continue.

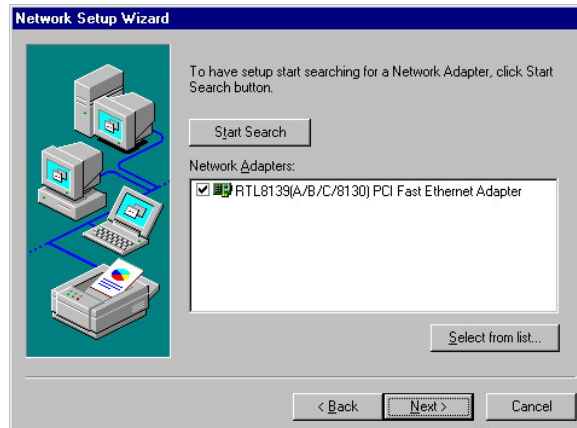

9. The Network Setup Wizard then allows you to set the Network Protocols on your network. Select the appropriate protocol and then click on Next to continue.

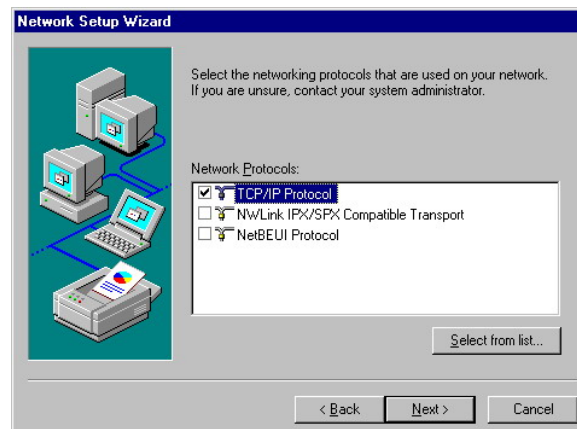

10. The Network Setup Wizard then allows you to set the Network Services on your Network, then click on Next to continue.

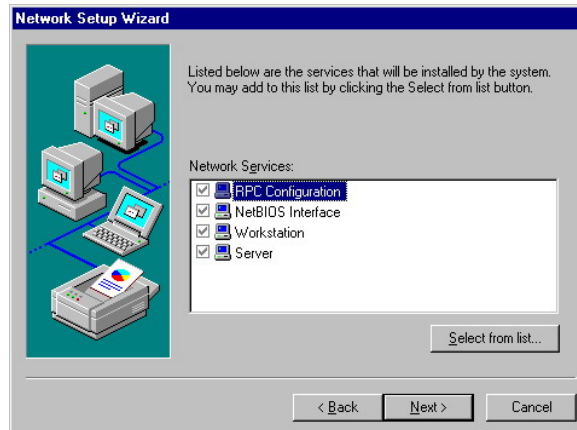

11. Before Setup starts installing the components found and the settings you made, it will give you the option to proceed or go back for changes from the following screen. Click on the Next button once you are sure of your devices.



12. Windows NT Setup will then need to copy files necessary to update the system information. Specify the path then press Continue.

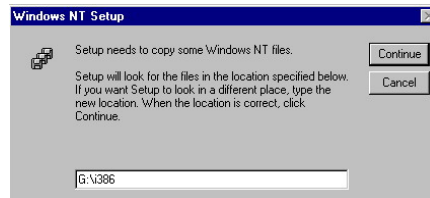

13. Once it finishes copying the files, Setup will now allow you to choose the Duplex Mode of your LAN controller. Press on the Continue button after making your selection.

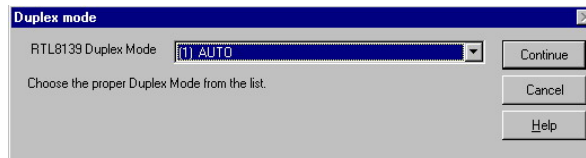

14. When Setup asks if you wish to change the TCP/IP settings of your system, select the appropriately. The default choice is No.

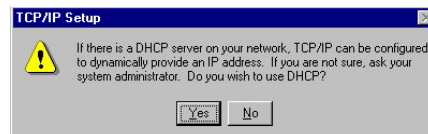

15. When the screen below appears, click on Next to continue.

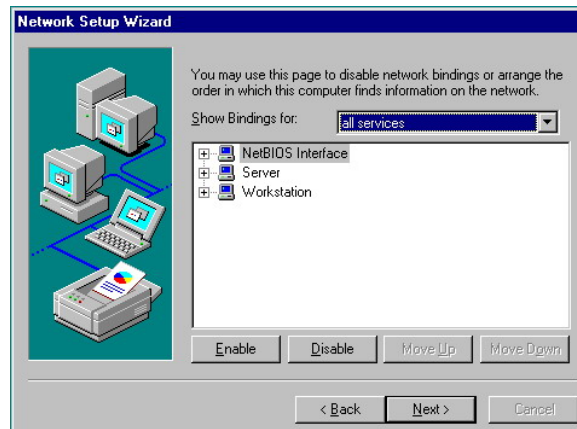



- Setup then prompts you that it is ready to start the network. You may complete the installation thereafter. Click on Next to continue.

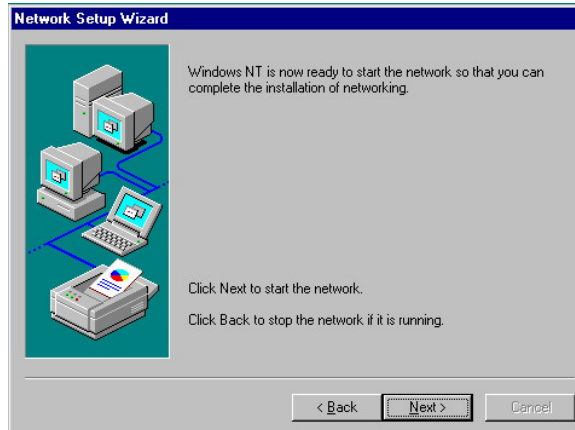

- Restart your computer. The LAN driver installation for WIN NT4.0 is now complete.

## 5.3 Audio Driver Installation

### 5.3.1 Audio Driver Installation for WIN98/2K/XP

- With the Utility CD Disk still in your CD ROM drive, open the File Manager and then select the driver folder. (If in E:, type E:\HS-2607 Driver\AC97)

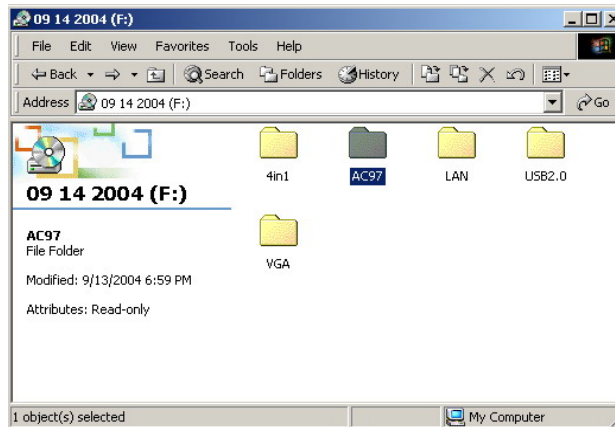

2. Press "Setup.exe" and to go setup.

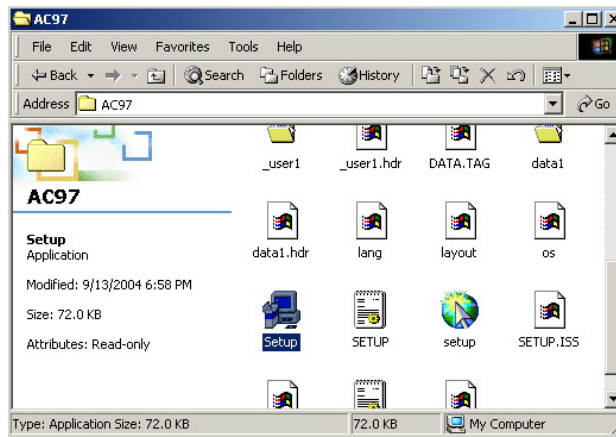

3. Once the Welcome screen appears on the screen, make sure to close applications that are running and then click the Next button.



4. The Select Components dialog box is now displayed. Select on Install driver and then click on Next.



5. After the audio driver installation finishes, select the Finish button to complete the installation process.



### 5.3.2 Audio Driver Installation for WINNT

1. With the Utility CD Disk still in your CD ROM drive, open the File Manager and then select the driver folder. (If in E:, type E:\HS-2607 Driver\AC97)

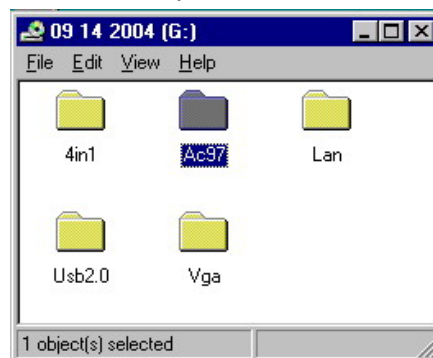

2. Press "Setup.exe" and to go setup.

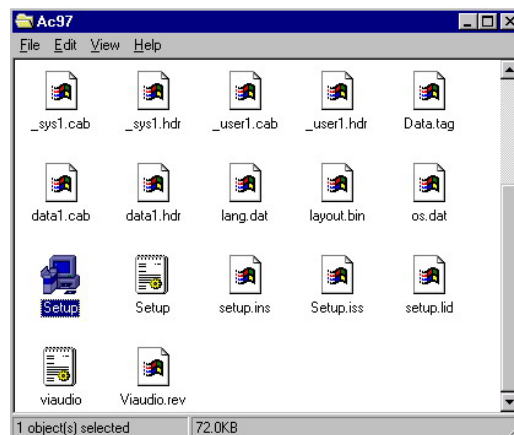

3. Once the Welcome screen appears on the screen, make sure to close applications that are running and then click the Next button.



4. The Select Components dialog box is now displayed. Select on VT8233/VT8235 and then click on Next.



5. After the audio driver installation finishes, select restart computer now, and click the Finish button to complete the installation process.



## 5.4 USB2.0 Driver Installation

### 5.4.1 Win 98

1. With the Utility CD Disk still in your CD ROM drive, right click on “**My Computer**” icon from the Windows menu. Select on System Properties and then proceed to the Device Manager from the main menu.

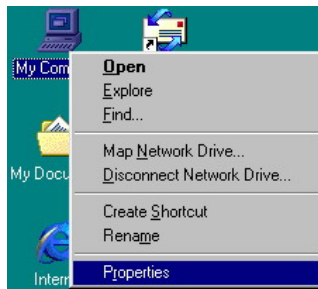

2. Select on Other Devices from the list of devices then double-click on PCI Universal Serial Bus.

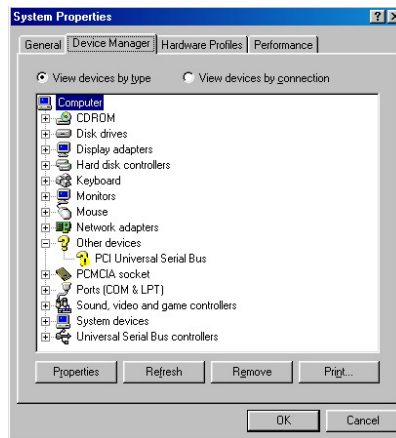

3. The PCI Universal Serial Bus Properties screen then appears, allowing you to re-install the driver. Select Driver from the main menu to proceed.



4. When the dialog box below appears, make sure you close all other Windows applications then click on the **Next >** button to proceed.





5. Tick on the “Search for a better driver” once the following screen appears. Click on the **Next** to proceed.



6. Once the program returns to the Add New Hardware Wizard screen, your specified location will appear. Press on the **Next** button to continue.



7. When Setup finds the information it needs about the new driver, it will display the device it found on the following screen. Press on the **Next** button to accept and proceed.



8. Once the InstallShield Wizard completes the operation and update of your USB2.0 driver. Click on the **Finish** button to complete the installation process.



### 5.4.2 Win 2000

1. With the Utility CD Disk still in your CD ROM drive, right click on "My Computer" icon from the Windows menu. Select on System Properties and then proceed to the Device Manager from the main menu.
2. Select on Other Devices from the list of devices then double-click on PCI Universal Serial Bus.

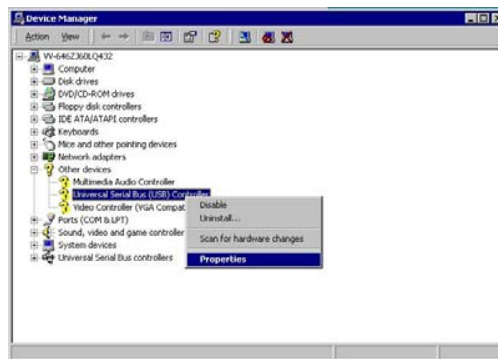

3. The PCI Universal Serial Bus Properties screen then appears, allowing you to re-install the driver. Select Driver from the main menu to proceed.

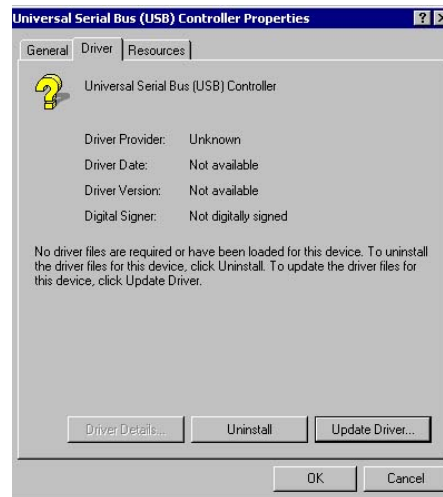

4. When the dialog box below appears, make sure you close all other Windows applications then click on the **Next >** button to proceed.



5. Tick on the "Search for a suitable driver" once the following screen appears. Click on the **Next** to proceed.

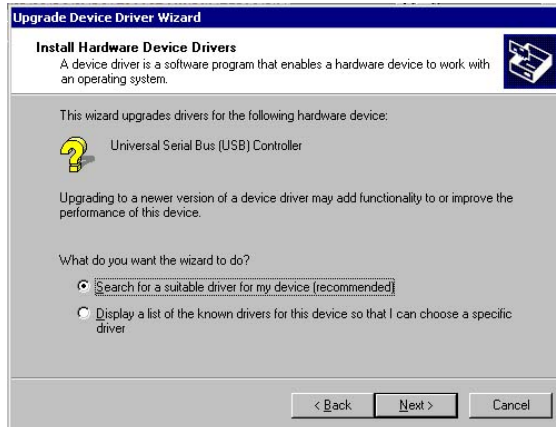

6. Once the program returns to the Add New Hardware Wizard screen, your specified location will appear. Press on the **Next** button to continue.



7. Choose sisusb2.inf and press on the **Open** button to accept and proceed.

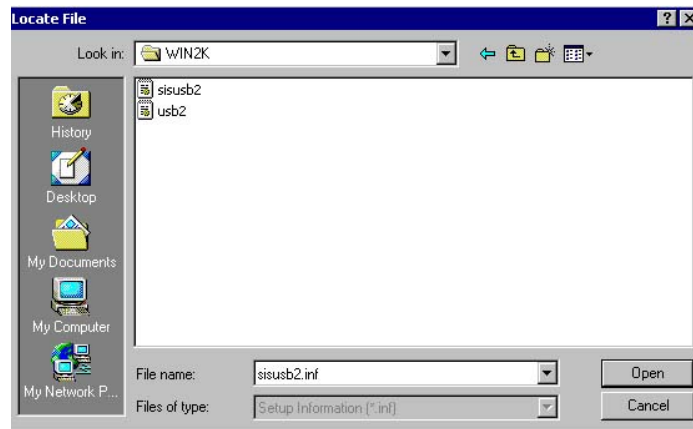

8. Once the InstallShield Wizard completes the operation and update of your USB2.0 driver. Click on the **Finish** button to complete the installation process.



### 5.4.3 Win XP

1. With the Utility CD Disk still in your CD ROM drive, open the File Manager and then select the driver folder. (If in E:, type E:\HS-2607 Driver\USB2.0)

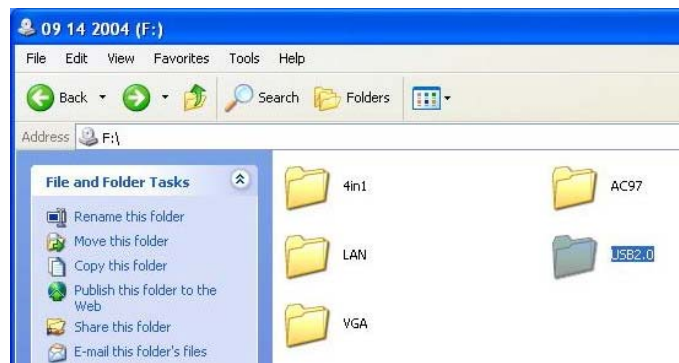

2. Click on "Setup.exe" and to go setup.

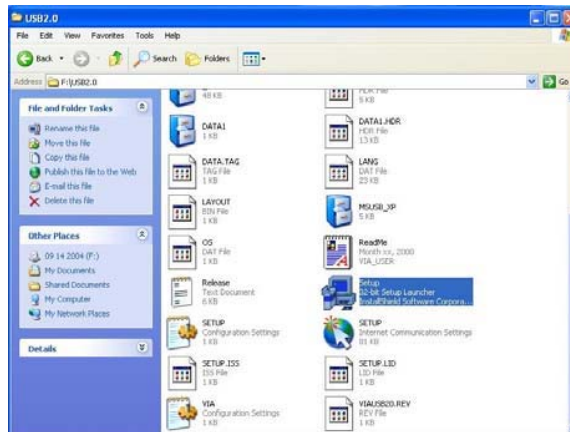

3. When the dialog box below appears, make sure you close all other Windows applications then click on the **Next >** button to proceed.

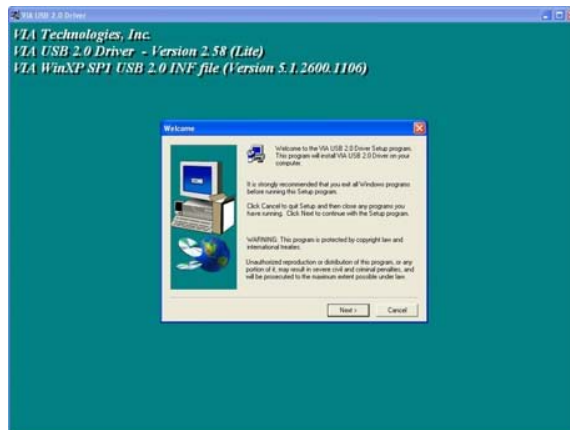

4. The program starts to install the USB2.0 driver when you click the Next> button on the screen below.

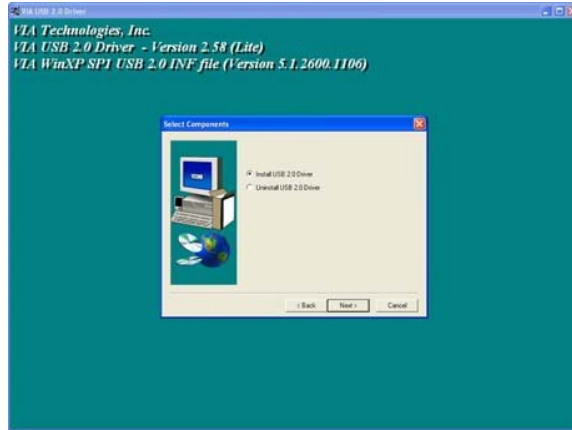

5. Once the InstallShield Wizard completes the operation and update of your USB2.0 driver. Click on the **Yes** button to restart computer to complete the installation process.

