

HD74BC245A

Octal Bus Transceivers With 3 State Outputs

REJ03D0282-0400Z
 (Previous ADE-205-008B (Z))
 Rev.4.00
 Jul.16.2004

Description

The HD74BC245A provides high drivability and operation equal to or better than high speed bipolar standard logic IC by using Bi-CMOS process. The device features low power dissipation that is about 1/5 of high speed bipolar logic IC, when the frequency is 10 MHz. The device has ten buffers with three state outputs in a 20 pin package. Each device has an active low enable input \overline{G} and a direction control input DiR. When DiR is high, data flows from the A inputs to the B outputs. When DiR is low, data flows from the B inputs to the A outputs. When \overline{G} is high, disables both A and B ports by placing them in a high impedance.

Features

- Input/Output are at high impedance state when power supply is off.
- Built in input pull up circuit can make input pins be open, when not used.
- TTL level input
- Wide operating temperature range
 $T_a = -40$ to $+85^\circ\text{C}$
- Ordering Information

Part Name	Package Type	Package Code	Package Abbreviation	Taping Abbreviation (Quantity)
HD74BC245AP	DILP-20 pin	DP-20N, -20NEV	P	—
HD74BC245AFPEL	SOP-20 pin (JEITA)	FP-20DAV	FP	EL (2,000 pcs/reel)
HD74BC245ATELL	TSSOP-20 pin	TTP-20DAV	T	ELL (2,000 pcs/reel)

Note: Please consults the sales office for the above package availability.

Function Table

Control Inputs		Operation
\overline{G}	DiR	
L	L	B data to A bus
L	H	A data to B bus
H	X	Z

H : High level
 L : Low level
 Z : High impedance

Pin Arrangement

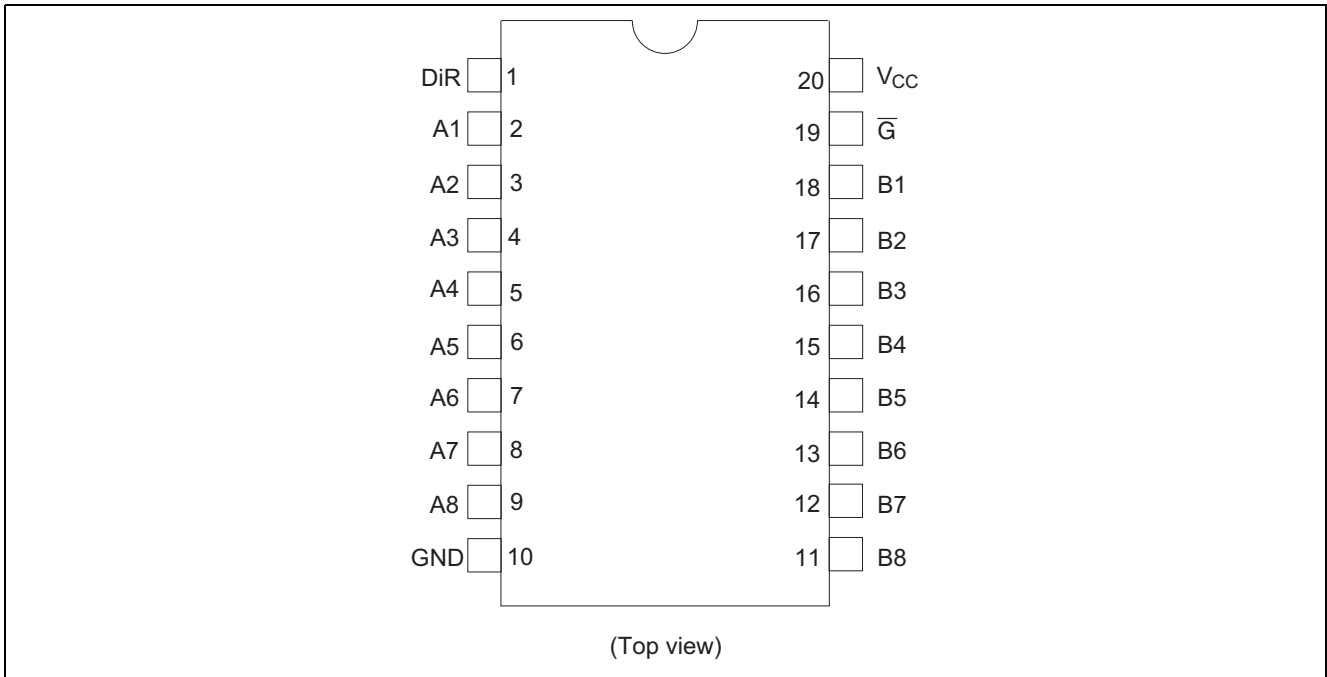

Absolute Maximum Ratings

Item	Symbol	Rating	Unit
Supply voltage	V_{CC}	-0.5 to +7.0	V
Input diode current	I_{IK}	± 30	mA
Input voltage	V_{IN}	-0.5 to +7.5	V
Output voltage	V_{OUT}	-0.5 to +7.5	V
Off state output voltage	$V_{OUT(off)}$	-0.5 to +5.5	V
Storage temperature	T_{stg}	-65 to +150	$^{\circ}C$

Note: 1. The absolute maximum ratings are values which must not individually be exceeded, and furthermore, no two of which may be realized at the same time.

Recommended Operating Conditions

Item	Symbol	Min	Typ	Max	Unit
Supply voltage	V_{CC}	4.5	5.0	5.5	V
Input voltage	V_{IN}	0	—	V_{CC}	V
Output voltage	V_{OUT}	0	—	V_{CC}	V
Operating temperature	T_{opr}	-40	—	85	$^{\circ}C$
Input rise/fall time*1	t_r, t_f	0	—	8	ns/V

Note: 1. This item guarantees maximum limit when one input switches.
Waveform: Refer to test circuit of switching characteristics.

Logic Diagram

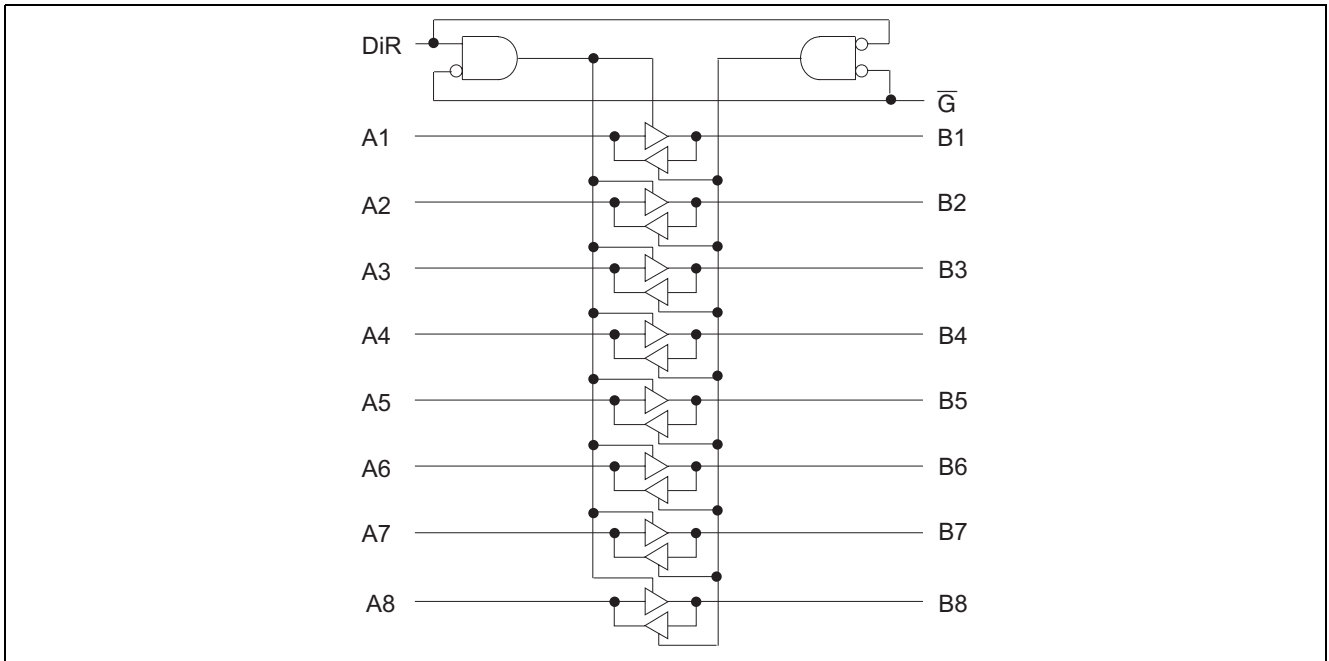

Electrical Characteristics (Ta = -40°C to +85°C)

Item	Symbol	V _{CC} (V)	Min	Max	Unit	Test Conditions
Input voltage	V _{IH}		2.0	—	V	
	V _{IL}		—	0.8	V	
Output voltage	V _{OH}	4.5	2.4	—	V	I _{OH} = -3 mA
		4.5	2.0	—	V	I _{OH} = -15 mA
	V _{OL}	4.5	—	0.5	V	I _{OL} = 48 mA
		4.5	—	0.55	V	I _{OL} = 64 mA
Input diode voltage	V _{IK}	4.5	—	-1.2	V	I _{IN} = -18 mA
Input current	I _I	5.5	—	-250	μA	V _{IN} = 0 V
		5.5	—	100	μA	An or Bn, V _{IN} = 5.5 V
		5.5	—	1.0	μA	DiR or \overline{G} , V _{IN} = 5.5 V
		5.5	—	100	μA	DiR or \overline{G} , V _{IN} = 7.0 V
Short circuit output current*1	I _{OS}	5.5	-100	-225	mA	V _O = 0 V, V _{IN} = 5.5 V
Off state output current	I _{OZH}	5.5	—	-100	μA	V _O = 2.7 V
	I _{OZL}	5.5	—	-250	μA	V _O = 0.5 V
Supply current	I _{CCL}	5.5	—	31.5	mA	V _{IN} = 0 or 5.5 V All outputs is "L"
	I _{CCH}	5.5	—	0.5	mA	V _{IN} = 0 or 5.5 V All outputs is "H"
	I _{CCZ}	5.5	—	4.5	mA	V _{IN} = 0 or 5.5 V All outputs is "Z"
	I _{CCT} *2	5.5	—	1.5	mA	V _{IN} = 3.4 or 0.5 V

Notes : 1. Not more than one output should be shorted at a time and duration of the short circuit should not exceed one second.

2. When input by the TTL level, it shows I_{CC} increase at per one input pin.

Switching Test Method (C_L = 50 pF)

Item	Symbol	Ta = 25°C V _{CC} = 5.0 V		Ta = -40 to 85°C V _{CC} = 5.0 V ±10%		Unit	Test Conditions
		Min	Max	Min	Max		
Propagation delay time	t _{PLH}	3.0	6.0	3.0	7.0	ns	An to Bn
	t _{PHL}	3.0	6.0	3.0	7.0		
	t _{PLH}	3.0	6.0	3.0	7.0	ns	Bn to An
	t _{PHL}	3.0	6.0	3.0	7.0		
Output enable time	t _{ZH}	3.0	9.0	3.0	11.0	ns	\overline{G} to Bn
	t _{ZL}	3.0	9.0	3.0	11.0		
	t _{ZH}	3.0	9.0	3.0	11.0	ns	\overline{G} to An
	t _{ZL}	3.0	9.0	3.0	11.0		
Output disable time	t _{HZ}	3.0	8.0	3.0	10.0	ns	\overline{G} to Bn
	t _{LZ}	3.0	8.0	3.0	10.0		
	t _{HZ}	3.0	8.0	3.0	10.0	ns	\overline{G} to An
	t _{LZ}	3.0	8.0	3.0	10.0		
Input capacitance	C _{IN}	3.0(Typ)		—		pF	V _{IN} = V _{CC} or GND
Input/output capacitance	C _{I/O}	15.0(Typ)		—		pF	V _{I/O} = V _{CC} or GND

Test Circuit

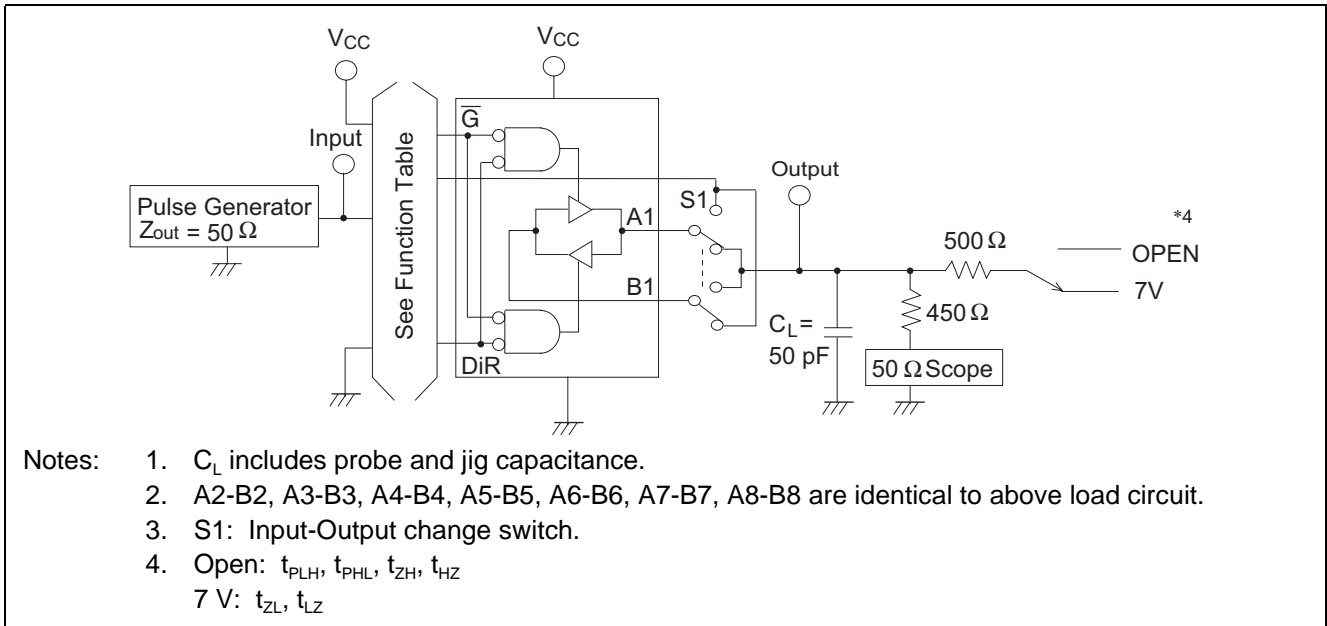

Waveforms-1

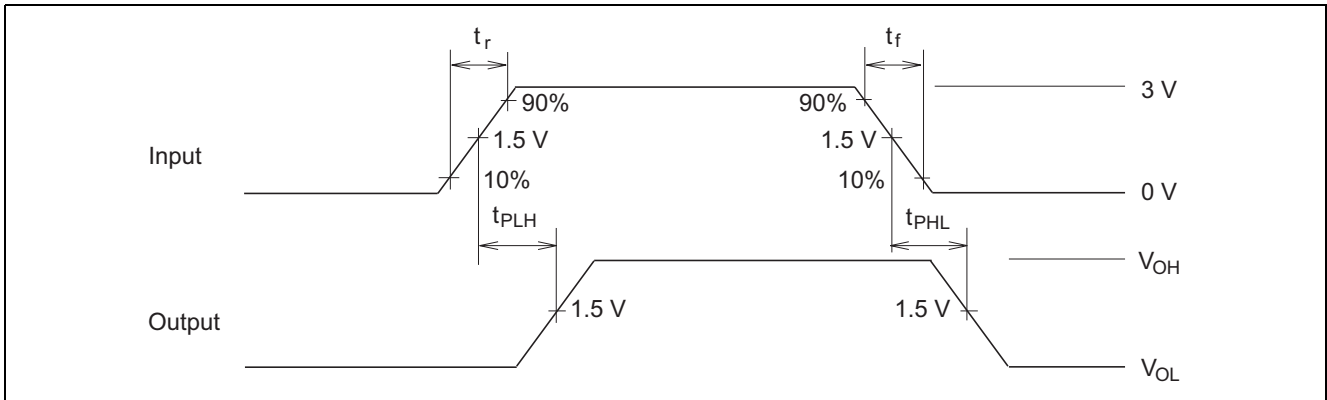

Waveforms-2

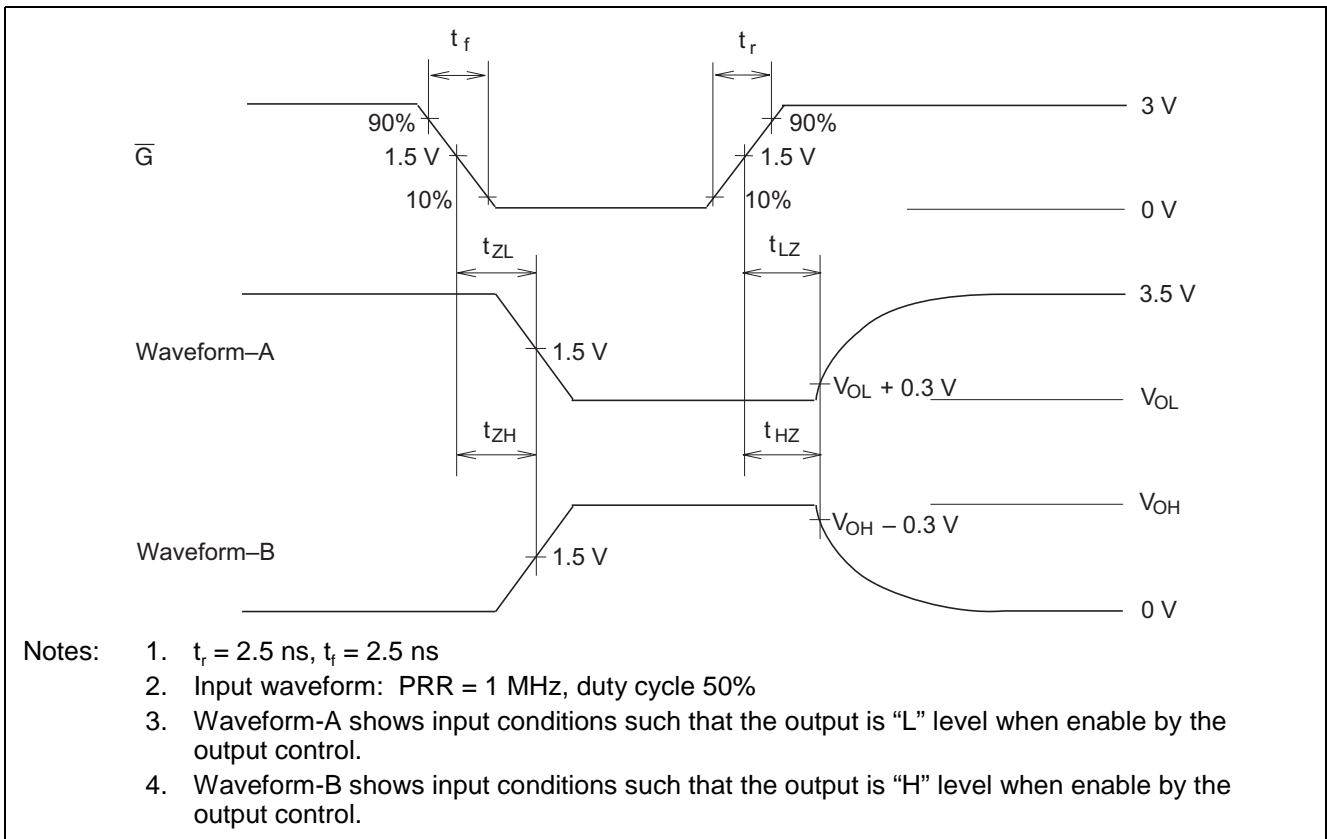

Package Dimensions

As of January, 2003
Unit: mm

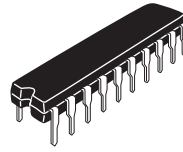
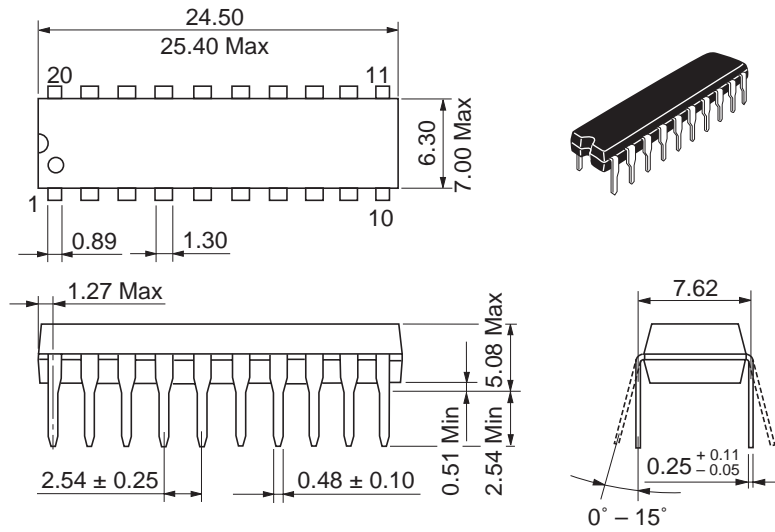

Package Code	DP-20N
JEDEC	—
JEITA	Conforms
Mass (reference value)	1.26 g

Unit: mm

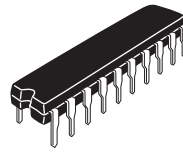
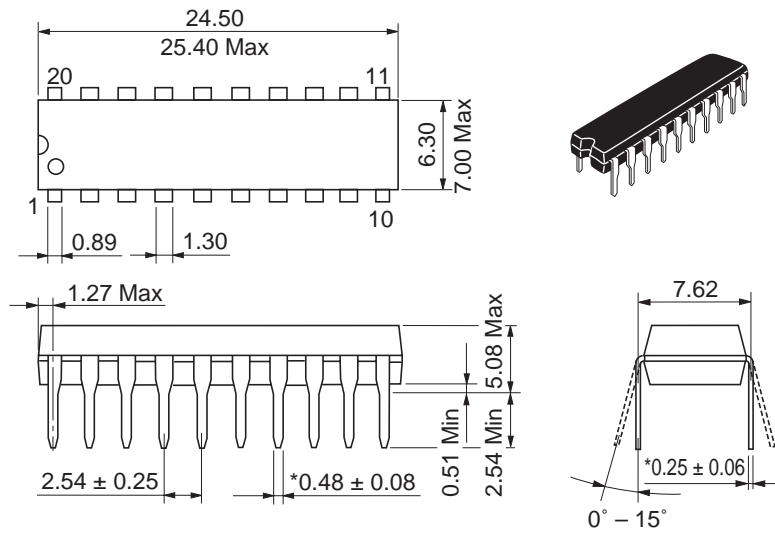

*Ni/Pd/AU Plating

Package Code	DP-20NEV
JEDEC	—
JEITA	Conforms
Mass (reference value)	1.26 g

As of January, 2003

Unit: mm

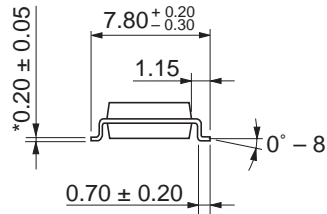
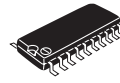
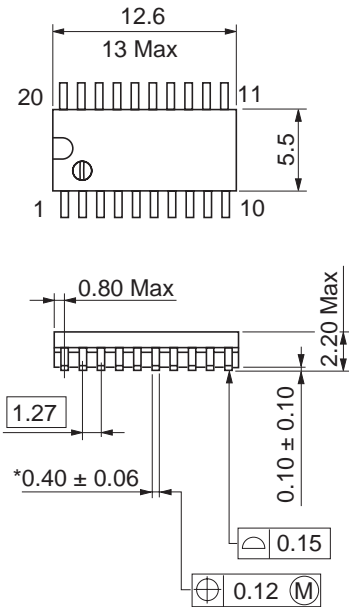

*Ni/Pd/Au plating

Package Code	FP-20DAV
JEDEC	—
JEITA	Conforms
Mass (reference value)	0.31 g

As of January, 2003

Unit: mm

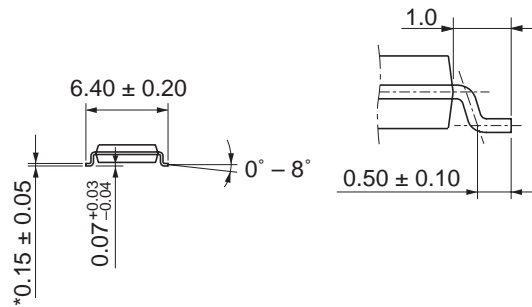
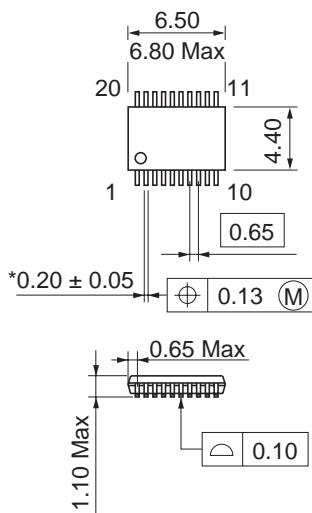

*Ni/Pd/Au plating

Package Code	TTP-20DAV
JEDEC	—
JEITA	—
Mass (reference value)	0.07 g

Renesas Technology Corp. Sales Strategic Planning Div. Nippon Bldg., 2-6-2, Ohte-machi, Chiyoda-ku, Tokyo 100-0004, Japan

Keep safety first in your circuit designs!

1. Renesas Technology Corp. puts the maximum effort into making semiconductor products better and more reliable, but there is always the possibility that trouble may occur with them. Trouble with semiconductors may lead to personal injury, fire or property damage. Remember to give due consideration to safety when making your circuit designs, with appropriate measures such as (i) placement of substitutive, auxiliary circuits, (ii) use of nonflammable material or (iii) prevention against any malfunction or mishap.

Notes regarding these materials

1. These materials are intended as a reference to assist our customers in the selection of the Renesas Technology Corp. product best suited to the customer's application; they do not convey any license under any intellectual property rights, or any other rights, belonging to Renesas Technology Corp. or a third party.
 2. Renesas Technology Corp. assumes no responsibility for any damage, or infringement of any third-party's rights, originating in the use of any product data, diagrams, charts, programs, algorithms, or circuit application examples contained in these materials.
 3. All information contained in these materials, including product data, diagrams, charts, programs and algorithms represents information on products at the time of publication of these materials, and are subject to change by Renesas Technology Corp. without notice due to product improvements or other reasons. It is therefore recommended that customers contact Renesas Technology Corp. or an authorized Renesas Technology Corp. product distributor for the latest product information before purchasing a product listed herein.
The information described here may contain technical inaccuracies or typographical errors.
Renesas Technology Corp. assumes no responsibility for any damage, liability, or other loss rising from these inaccuracies or errors.
Please also pay attention to information published by Renesas Technology Corp. by various means, including the Renesas Technology Corp. Semiconductor home page (<http://www.renesas.com>).
 4. When using any or all of the information contained in these materials, including product data, diagrams, charts, programs, and algorithms, please be sure to evaluate all information as a total system before making a final decision on the applicability of the information and products. Renesas Technology Corp. assumes no responsibility for any damage, liability or other loss resulting from the information contained herein.
 5. Renesas Technology Corp. semiconductors are not designed or manufactured for use in a device or system that is used under circumstances in which human life is potentially at stake. Please contact Renesas Technology Corp. or an authorized Renesas Technology Corp. product distributor when considering the use of a product contained herein for any specific purposes, such as apparatus or systems for transportation, vehicular, medical, aerospace, nuclear, or undersea repeater use.
 6. The prior written approval of Renesas Technology Corp. is necessary to reprint or reproduce in whole or in part these materials.
 7. If these products or technologies are subject to the Japanese export control restrictions, they must be exported under a license from the Japanese government and cannot be imported into a country other than the approved destination.
Any diversion or reexport contrary to the export control laws and regulations of Japan and/or the country of destination is prohibited.
 8. Please contact Renesas Technology Corp. for further details on these materials or the products contained therein.
-



RENESAS SALES OFFICES

<http://www.renesas.com>

Renesas Technology America, Inc.

450 Holger Way, San Jose, CA 95134-1368, U.S.A
Tel: <1> (408) 382-7500 Fax: <1> (408) 382-7501

Renesas Technology Europe Limited.

Dukes Meadow, Millboard Road, Bourne End, Buckinghamshire, SL8 5FH, United Kingdom
Tel: <44> (1628) 585 100, Fax: <44> (1628) 585 900

Renesas Technology Europe GmbH

Dornacher Str. 3, D-85622 Feldkirchen, Germany
Tel: <49> (89) 380 70 0, Fax: <49> (89) 929 30 11

Renesas Technology Hong Kong Ltd.

7/F., North Tower, World Finance Centre, Harbour City, Canton Road, Hong Kong
Tel: <852> 2265-6688, Fax: <852> 2375-6836

Renesas Technology Taiwan Co., Ltd.

FL 10, #99, Fu-Hsing N. Rd., Taipei, Taiwan
Tel: <886> (2) 2715-2888, Fax: <886> (2) 2713-2999

Renesas Technology (Shanghai) Co., Ltd.

26/F., Ruijin Building, No.205 Maoming Road (S), Shanghai 200020, China
Tel: <86> (21) 6472-1001, Fax: <86> (21) 6415-2952

Renesas Technology Singapore Pte. Ltd.

1, Harbour Front Avenue, #06-10, Keppel Bay Tower, Singapore 098632
Tel: <65> 6213-0200, Fax: <65> 6278-8001