

Silicon NPN Power Transistors

S2055

**DESCRIPTION**

- With TO-3PH package
- High voltage ,high speed
- Low collector saturation voltage
- Built-in damper diode

**APPLICATIONS**

- Color TV horizontal output applications
- Color TV switching regulator applications

**PINNING** □ See Fig.2 □

PIN	DESCRIPTION
1	Base
2	Collector;connected to mounting base
3	Emitter

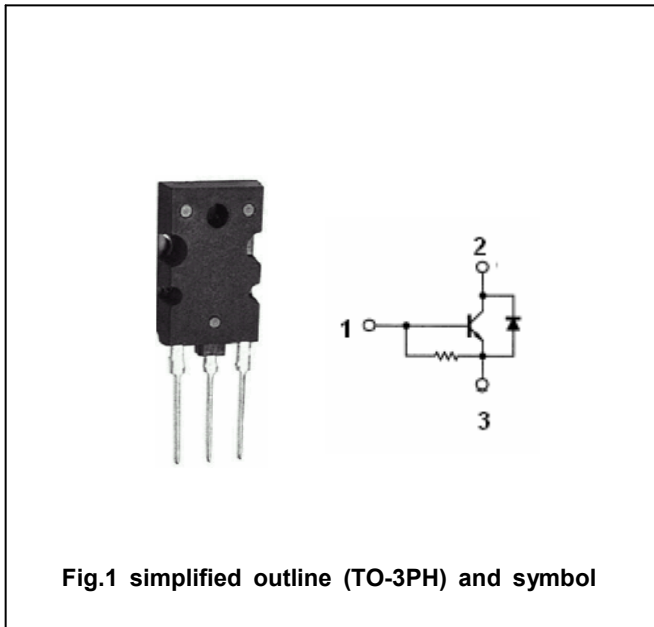

**ABSOLUTE MAXIMUM RATINGS (T<sub>C</sub>=25□)**

SYMBOL	PARAMETER	CONDITIONS	VALUE	UNIT
V <sub>CBO</sub>	Collector-base voltage	Open emitter	1500	V
V <sub>CEO</sub>	Collector-emitter voltage	Open base	700	V
V <sub>EBO</sub>	Emitter-base voltage	Open collector	5	V
I <sub>C</sub>	Collector current		8	A
I <sub>CM</sub>	Collector current-peak		15	A
I <sub>B</sub>	Base current		4	A
P <sub>C</sub>	Collector power dissipation	T <sub>C</sub> =25□	125	W
T <sub>j</sub>	Junction temperature		150	□
T <sub>stg</sub>	Storage temperature		-55~150	□

## Silicon NPN Power Transistors

S2055

## CHARACTERISTICS

T<sub>j</sub>=25°C unless otherwise specified

SYMBOL	PARAMETER	CONDITIONS	MIN	TYP.	MAX	UNIT
V <sub>CEQ(SUS)</sub>	Collector-emitter sustaining voltage	I <sub>B</sub> =500mA ; V <sub>BE</sub> =-1.7V; L=40mH	700			V
V <sub>CE(sat)</sub>	Collector-emitter saturation voltage	I <sub>C</sub> =4.5A ; I <sub>B</sub> =1.0A			5.0	V
V <sub>BE(sat)</sub>	Base-emitter saturation voltage	I <sub>C</sub> =4.5A ; I <sub>B</sub> =1.0A			1.2	V
I <sub>CBO</sub>	Collector cut-off current	V <sub>CB</sub> =1500V; V <sub>BE</sub> =0			1.0	mA
I <sub>EBO</sub>	Emitter cut-off current	V <sub>EB</sub> =5V; I <sub>C</sub> =0			300	mA
h <sub>FE-1</sub>	DC current gain	I <sub>C</sub> =1A ; V <sub>CE</sub> =5V	10		30	
h <sub>FE-2</sub>	DC current gain	I <sub>C</sub> =4.5A ; V <sub>CE</sub> =5V	4.5		9	
C <sub>OB</sub>	Collector output capacitance	I <sub>E</sub> =0 ; V <sub>CB</sub> =10V; f=1MHz		95		pF
f <sub>T</sub>	Transition frequency	I <sub>C</sub> =0.1A ; V <sub>CE</sub> =10V		2		MHz

Silicon NPN Power Transistors

S2055

PACKAGE OUTLINE

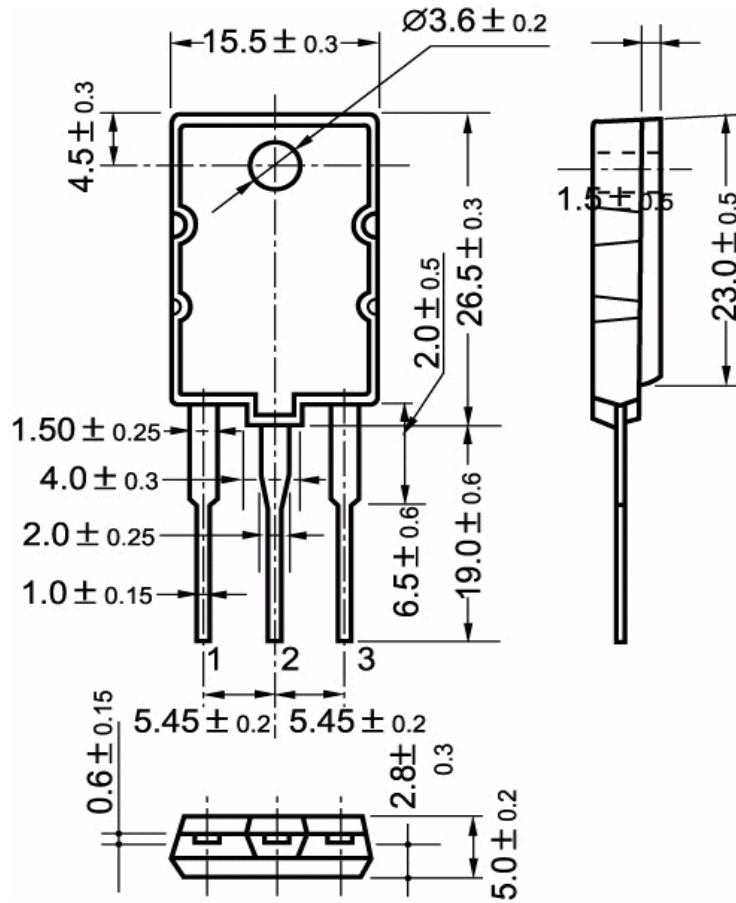

Fig.2 outline dimensions