

## MPC5606S

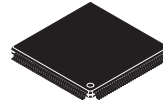

LQFP-144  
20 mm x 20 mm

LQFP-176  
24 mm x 24 mm

## MPC560xS Microcontroller Data Sheet

### 32-bit MCU for cluster applications with stepper motor, TFT graphic controller and LCD driver

The MPC5606S family of devices is designed to enable the development of automotive instrument cluster applications by providing a single-chip solution capable of hosting real-time applications and driving a TFT display directly using an on-chip color TFT display controller.

MPC5606S devices incorporate a cost-efficient host processor core compliant with the Power Architecture™ embedded category. The processor is 100% user-mode compatible with the original PowerPC user instruction set architecture (UISA) and capitalizes on the available development infrastructure of current Power Architecture™ devices with full support from available software drivers, operating systems and configuration code to assist with users' implementations.

Offering high performance processing at speeds up to 64 MHz, the MPC5606S family is optimized for low power consumption and supports a range of on-chip SRAM and internal flash memories. The 1 MB flash version (MPC5606S) features 160 KB of on-chip graphics SRAM.

Refer to [Table 1](#) for specific memory and feature sets of the product family members.

This document describes the features of the MPC5606S family of microcontrollers and highlights important electrical and physical characteristics of the devices. For functional characteristics, refer to the MPC5606S *Microcontroller Reference Manual*.

This document contains information on a product under development. Freescale reserves the right to change or discontinue this product without notice.

© Freescale Semiconductor, Inc., 2008. All rights reserved.



**Preliminary—Subject to Change Without Notice**

# Table of Contents

1	Overview	3	3.6.2	I/O Input DC Characteristics	50
1.1	Device Comparison	3	3.6.3	I/O Output DC Characteristics	51
1.2	MPC5606S Features	5	3.6.4	I/O Pad Current Specification	55
1.3	MPC5606S Series Blocks	6	3.7	RESET electrical characteristics	57
1.3.1	Block Diagram	6	3.8	Main Oscillator Electrical Characteristics	59
1.3.2	Block Summary	7	3.9	Low Power Oscillator Electrical Characteristics	61
2	Pinout and Signal Descriptions	9	3.10	FMPLL Electrical Characteristics	62
2.1	144 LQFP Package Pinout	10	3.11	Main RC Oscillator Electrical Characteristics	63
2.2	176 LQFP Package Pinout	11	3.12	Low Power RC Oscillator Electrical Characteristics	64
2.3	208 MAPBGA Package Pinout	11	3.13	Flash Memory Electrical Characteristics	64
2.4	Signal Description	13	3.14	Analog to Digital Converter (ADC) Electrical Characteristics	65
2.4.1	Pad Configuration during Reset Phases	13	3.14.1	Input Impedance and ADC Accuracy	66
2.4.2	Voltage Supply Pins	13	3.14.2	ADC Electrical Characteristics	70
2.4.3	Pad Types	15	3.15	AC Specifications	72
2.4.4	System Pins	15	3.15.1	Pad AC Specifications	72
2.4.5	Nexus Pins	16	3.16	AC Timing	74
2.4.6	Functional Ports A, B, C, D, E, F, G, H, I, J, K	18	3.16.1	IEEE 1149.1 Interface Timing	74
2.4.7	Signal Details	36	3.16.2	Nexus Debug Interface	77
3	Electrical Characteristics	39	3.16.3	Interface to TFT LCD Panels	78
3.1	Absolute Maximum Ratings	39	3.16.4	External Interrupt (IRQ) and Non-Maskable Interrupt (NMI) Timing	81
3.1.1	Recommended Operating Conditions	41	3.16.5	Enhanced Modular I/O Subsystem (eMIOS) Timing	82
3.2	Thermal Characteristics	44	3.16.6	FlexCAN Timing	82
3.2.1	General Notes for Specifications at Maximum Junction Temperature	45	3.16.7	Deserial Serial Peripheral Interface (DSPI)	83
3.3	EMI (Electromagnetic Interference) Characteristics	47	3.16.8	I <sup>2</sup> C Timing	88
3.4	Power Management	47	3.16.9	Mechanical Outline Drawings	89
3.4.1	Voltage Regulator Electrical Characteristics	47	3.17	144 LQFP	89
3.4.2	Voltage monitor electrical characteristics	48	3.18	176 LQFP	93
3.4.3	Low voltage domain power consumption	49	4	Ordering Information	96
3.5	DC Electrical Specifications	50			
3.6	I/O Pad Electrical Characteristics	50			
3.6.1	I/O Pad Types	50			

# 1 Overview

The following sections provide high-level descriptions of the features found on the MPC5606S.

## 1.1 Device Comparison

**Table 1. MPC5606S Family**

Feature	MPC5602S	MPC5604S	MPC5606S
CPU	e200z0h		
Execution Speed	Static - 64 MHz		
Flash (ECC)	256 KB	512 KB	1 MB
EEPROM Emulation Block (ECC)	4 × 16 KB		
RAM (ECC)	24 KB	48 KB	48 KB
Graphics RAM	No	No	160 KB
MPU	12 entry		
eDMA	16 channels		
Display Control Unit	No	No	Yes
Parallel Data Interface	No	No	Yes
Stepper Motor Controller	6 motors		
Stepper Motor Stall Detect	Yes		
Sound Generation	Yes	Yes	Using eMIOS
LCD Segment Driver	64 × 6	64 × 6	40 × 4, 38 × 6 <sup>1</sup>
32 kHz External Crystal Oscillator	Yes		
Real Time Counter and Autonomous Periodic Interrupt	Yes	Yes	Yes
Periodic Interrupt Timer	4 ch, 32-bit		
System Watchdog Timer	Yes		
System Timer Module	4 ch, 32-bit		
Timed I/O <sup>2</sup>	8 ch, 16-bit IC/OC		
	16 ch, 16-bit OPWM/IC/OC		
ADC <sup>3</sup>	16 channels, 10-bit		
CAN (64 Mailboxes)	1 × FlexCAN	2 × FlexCAN	2 × FlexCAN
CAN Sampler	Yes		
SCI	2 × LINFlex		
SPI	2 × DSPI	2 × DSPI	3 <sup>4</sup> × DSPI
QuadSPI Serial Flash Interface	No	No	Yes

Table 1. MPC5606S Family (continued)

Feature	MPC5602S	MPC5604S	MPC5606S
I <sup>2</sup> C	2	2	4
GPIO	105	105	105 / 132
Debug	Nexus 1	Nexus 1	Nexus 2+ <sup>5</sup>
Package	144 LQFP	144 LQFP	144 LQFP <sup>6</sup> 176 LQFP 208 MAPBGA <sup>7</sup>

<sup>1</sup> Configuration is software-programmable

<sup>2</sup> IC-Input Capture, OC-Output Compare, OPWM-Output Pulse Width Modulation

<sup>3</sup> Support for external multiplexer enabling up to 23 channels

<sup>4</sup> QuadSPI serial Flash controller can be optionally used as a third DSPI

<sup>5</sup> Nexus2+ available on 176 LQFP as alternate pin function and on 208 MAPBGA

<sup>6</sup> Not all features are available simultaneously in 144 LQFP package option

<sup>7</sup> The 208-pin package is not a production package; it is available in limited quantities for tool development only.

## 1.2 MPC5606S Features

- Single issue, 32-bit Power Architecture Book E compliant CPU core complex (e200z0h)
  - Compatible with classic PowerPC instruction set
  - Includes variable length encoding (VLE) instruction set for smaller code size footprint; with the encoding of mixed 16-bit and 32-bit instructions, it is possible to achieve significant code size footprint reduction over conventional Book E compliant code
- On-chip ECC flash memory with flash controller
  - Up to 1 MB primary flash—two 512 KB modules with prefetch buffer and 128-bit data access port
  - 64 KB data flash—separate 4×16 KB flash block for EEPROM Emulation with prefetch buffer and 128-bit data access port
- Up to 48 KB on-chip ECC SRAM with SRAM controller
- Up to 160 KB on-chip non-ECC graphics SRAM with SRAM controller
- Memory protection unit (MPU) with up to 12 region descriptors and 32-byte region granularity to provide basic memory access permission
- Interrupt controller (INTC) with up to 127 peripheral interrupt sources and eight software interrupts
- Two frequency-modulated phase-locked loops (FMPLLs)
  - Primary FMPLL provides a 64 MHz system clock
  - Auxiliary FMPLL is available for use as an alternate, modulated or non-modulated clock source to eMIOS modules and as alternate clock to the DCU for pixel clock generation
- Crossbar switch architecture enables concurrent access of peripherals, flash memory or RAM from multiple bus masters (AMBA 2.0 v6 AHB)
- 16-channel enhanced direct memory access controller (eDMA) with multiple transfer request sources using a DMA channel multiplexer
- Boot assist module (BAM) for embedded boot code supports boot options including download of code via a serial link (CAN or SPI)
- Display control unit to drive TFT LCD displays. It includes processing of up to four planes that can be blended together and offers a direct un-buffered hardware bit-blitter of up to 16 software-configurable dynamic layers in order to drastically minimize graphic memory requirements and provide fast animations. Programmable display resolutions are available up to WVGA.
- Parallel Data Interface for digital video input
- The LCD segment driver module has two software programmable configurations:
  - Up to 40 front plane drivers and 4 backplane drivers
  - Up to 38 frontplane drivers and 6 backplane drivers
- Stepper Motor Controller module with high-current drivers for up to six instrument cluster gauges driven in full dual H-Bridge configuration including full diagnostics for short circuit detection
- Stepper motor return-to-zero and stall detection module
- Sound generation and playback utilizing PWM channels and eDMA; supports monotonic and polyphonic sound
- 24 eMIOS channels providing up to 16 PWM and 24 input capture / output compare channels
- 10-bit analog-to-digital converter (ADC) with a maximum conversion time of 1μs
  - 16 internal channels
  - Extendable to eight multiplexed external channels
- Up to three DSPI (Deserial Serial Peripheral Interface) modules for full-duplex, synchronous, communications with external devices
- QuadSPI serial flash memory controller supporting single, dual and quad modes of operation to interface to external serial flash memory or optionally can be configured to function as another DSPI module (MPC5606S only)
- Two Local Interconnect Network (LIN) controller modules capable of autonomous message handling (master), autonomous header handling (slave mode), and UART support. Compliant with LIN protocol rev 2.1

## Overview

- Two full CAN 2.0B controllers with 64 configurable buffers each; the bit rate can be programmed up to 1 Mb/s
- Up to four Inter-integrated circuit (I<sup>2</sup>C) internal bus controllers with master/slave bus interface
- Up to 132 configurable general purpose pins supporting input and output operations
- Real Time Counter (RTC). Clock sources are:
  - Internal 128 kHz or 16 MHz RC oscillator supporting autonomous wake-up with 1 ms resolution with maximum timeout of 2 seconds
  - External 32 kHz crystal oscillator, supporting wake-up with 1 s resolution and maximum timeout of one hour
  - External 4 - 16 MHz oscillator
- System Timers:
  - 4-channel 32-bit System Timer Module (STM)—included in processor platform
  - 4-channel 32-bit Periodic Interrupt Timer (PIT) module
  - System watchdog timer
- System Integration Unit (SIU) module to manage resets, external interrupts, GPIO and pad control
- System Status and Configuration Module (SSCM) to provide information for identification of the device, last boot mode, or debug status and provides an entry point for the censorship password mechanism
- Clock Generation Module (CGM) to generate system clock sources and provide a unified register interface, enabling access to all clock sources
- Clock Monitor Unit (CMU) to monitor the integrity of the main crystal oscillator and the PLL and act as a frequency meter, measuring the frequency of one clock source and comparing it to a reference clock
- Mode Entry Module (MEM) to control the device power mode, i.e., RUN, HALT, STOP, or STANDBY, control mode transition sequences, and manage the power control, voltage regulator, clock generation and clock management modules
- Reset Generation Module (RGM) to manage reset assertion and release to the device at initial power-up
- Nexus development interface (NDI) per IEEE-ISTO 5001-2003 Class Two Plus standard
- Device/board boundary-scan testing supported per Joint Test Action Group (JTAG) of IEEE (IEEE 1149.1)
- On-chip voltage regulator controller for regulating the 3.3 or 5 V supply voltage down to 1.2 V for core logic (requires external ballast transistor)
- The MPC5606S microcontrollers are offered in the following packages:<sup>1</sup>
  - 144 LQFP, 0.5 mm pitch, 20 mm × 20 mm outline
  - 176 LQFP, 0.5 mm pitch, 24 mm × 24 mm outline
  - 208 MAPBGA, 1.0 mm pitch, 17 mm × 17 mm outline

## 1.3 MPC5606S Series Blocks

### 1.3.1 Block Diagram

Figure 1 shows a top-level block diagram of the MPC5606S series.

---

1. See the device comparison table or orderable parts summary for package offerings for each device in the family.

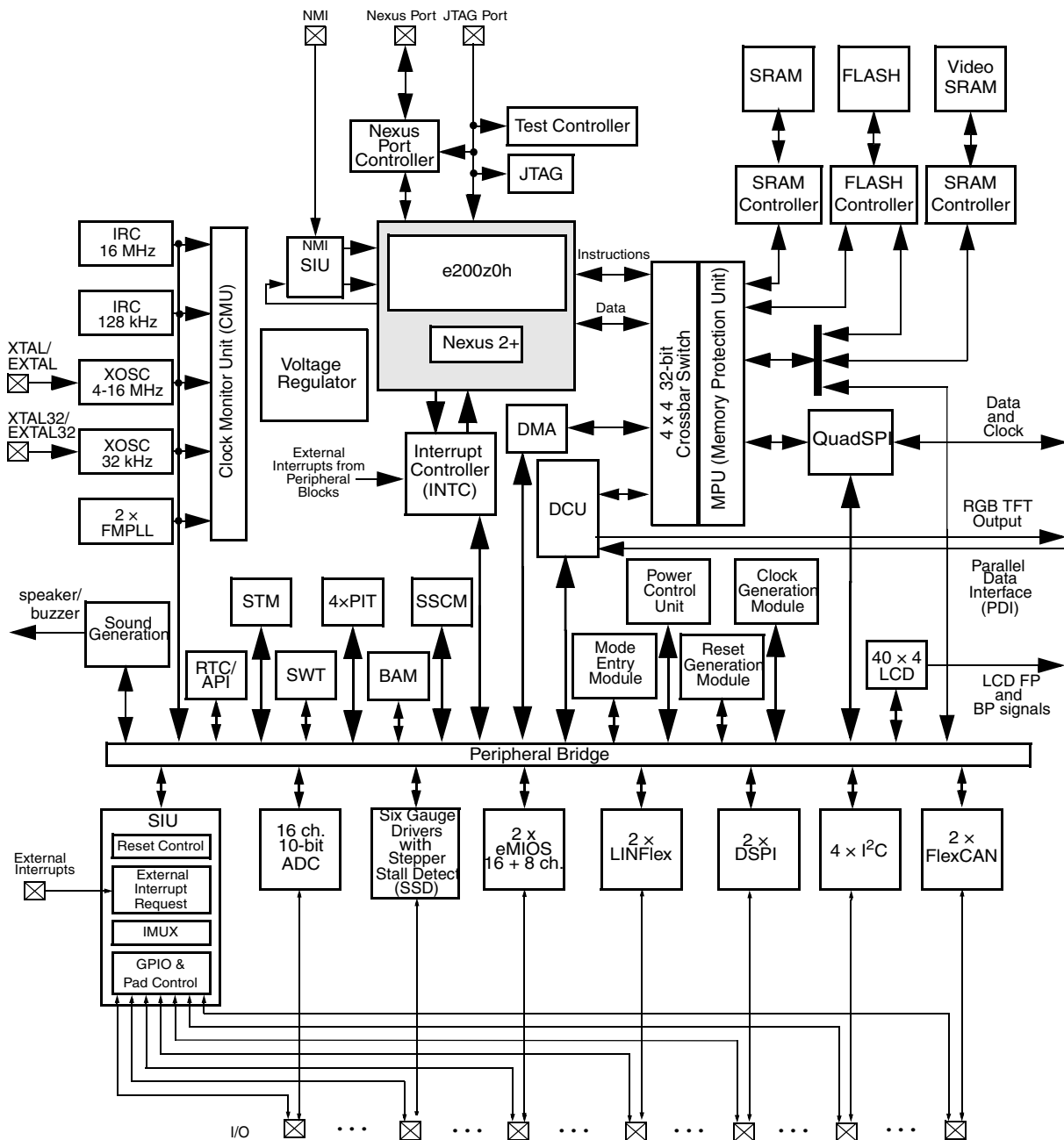

Figure 1. MPC5606S Series Block Diagram

### 1.3.2 Block Summary

Table 2 summarizes the functions of all blocks present in the MPC5606S series microcontrollers. Please note that the presence and number of blocks varies by device and package.

Table 2. MPC5606S Series Block Summary

Block	Function
16-channel 2nd-generation Direct Memory Access (eDMA)	Second-generation platform module capable of performing complex data transfers with minimal intervention from a host processor via “n” programmable channels
AHB crossbar switch “lite” (XBAR-Lite)	Internal busmaster
Analog-to-digital converter (ADC)	16-channel, 10-bit analog to digital converter
Boot assist module (BAM)	A block of read-only memory containing VLE code which is executed according to the boot mode of the device
Clock generation module (CGM)	Provides logic and control required for the generation of system and peripheral clocks
Clock monitor unit (CMU)	Monitors clock source (internal and external) integrity
Display control unit (DCU)	Generates all signals required to drive a TFT LCD display, allowing blending of data of up to 16 layers; can also display digital video/graphics in the background plane
Deserial serial peripheral interface (DSPI)	Provides a synchronous serial interface for communication with external devices
QuadSPI (QSPI)	Provides a synchronous serial bus for communication with external serial flash memory and is optionally configurable as a third DSPI module
Enhanced modular input output system (eMIOS)	Provides the functionality to generate or measure events
Flash memory	Provides non-volatile storage for program code, constants and variables
FlexCAN (controller area network)	Supports the standard CAN communications protocol
FMPLL (frequency-modulated phase-locked loop)	Two FMPLLs generate high-speed system clocks and support programmable frequency modulation
Inter-integrated circuit (I <sup>2</sup> C™) bus	A two wire bidirectional serial bus that provides a simple and efficient method of data exchange between devices
Interrupt controller (INTC)	Provides priority-based preemptive scheduling of interrupt requests
JTAG controller	Provides the means to test chip functionality and connectivity while remaining transparent to system logic when not in test mode
LCD driver module	Provides 40 × 4 (frontplane drivers × backplane drivers) or 6 × 38 driver configuration for driving LCD segments
LINflex controller	Manages a high number of LIN (Local Interconnect Network protocol) messages efficiently with a minimum of CPU load
Memory protection unit (MPU)	Provides hardware access control for all memory references generated in a device
Error Correction Status Module (ECSM)	Provides miscellaneous control functions including program-visible information about the platform configuration and revision levels, a reset status register, wakeup control for exiting sleep modes, and generic access error information for the processor core



Table 2. MPC5606S Series Block Summary (continued)

Block	Function
Mode entry module (MEM)	Provides a mechanism for controlling the device operational mode and mode transition sequences in all functional states; also manages the power control unit, reset generation module and clock generation module, and holds the configuration, control and status registers accessible for applications
Nexus development interface (NDI) level	Provides real-time development support capabilities in compliance with the IEEE-ISTO 5001-2003 standard
Peripheral interrupt timer (PIT)	Produces periodic interrupts and triggers
Power control unit (PCU)	Reduces the overall power consumption by disconnecting parts of the device from the power supply via a power switching device; device components are grouped into sections called “power domains” which are controlled by the PCU
Static random-access memory (SRAM)	Provides storage for program code, constants, and variables
Reset generation module (RGM)	Centralizes reset sources and manages the device reset sequence of the device
Real time counter (RTC)	A free running counter used for time keeping applications, the RTC can be configured to generate an interrupt at a pre-defined interval independent of the mode of operation (run mode or low-power mode)
Sound generation logic (SGL)	Provides monotonic and polyphonic sound generation capability
Stepper motor controller (SMC)	A PWM motor controller suitable for driving instruments in a cluster configuration or any other loads requiring a PWM signal
Stepper stall detect (SDD)	The SSD module connects to one stepper (SM) motor with 2 coils and is used to monitor the movement of the SM to detect that the attached gauge pointer has reached the stall position of the scale
System integration unit (SIU)	Provides control over all the electrical pad controls and up to 32 ports with 16 bits of bidirectional, general-purpose input and output signals and supports up to 32 external interrupts with trigger event configuration
System status configuration module (SSCM)	Provides system configuration and status data, e.g., memory size and status, device mode and security status, DMA status, etc., device identification data, debug status port enable and selection, and bus and peripheral abort enable/disable
System timer (STM)	Provides a set of output compare events to support AutoSAR and operating system tasks
System watchdog timer (SWT)	Provides protection from runaway code
Test control unit (TCU)	An extension of the JTAG controller module, the TCU provides the means to test chip functionality and connectivity while remaining transparent to system logic when not in test mode

## 2 Pinout and Signal Descriptions

## 2.1 144 LQFP Package Pinout

Figure 2 shows the pinout for the 144-pin LQFP package.

### WARNING

Any pins labeled “NC” must not be connected to any external circuit.

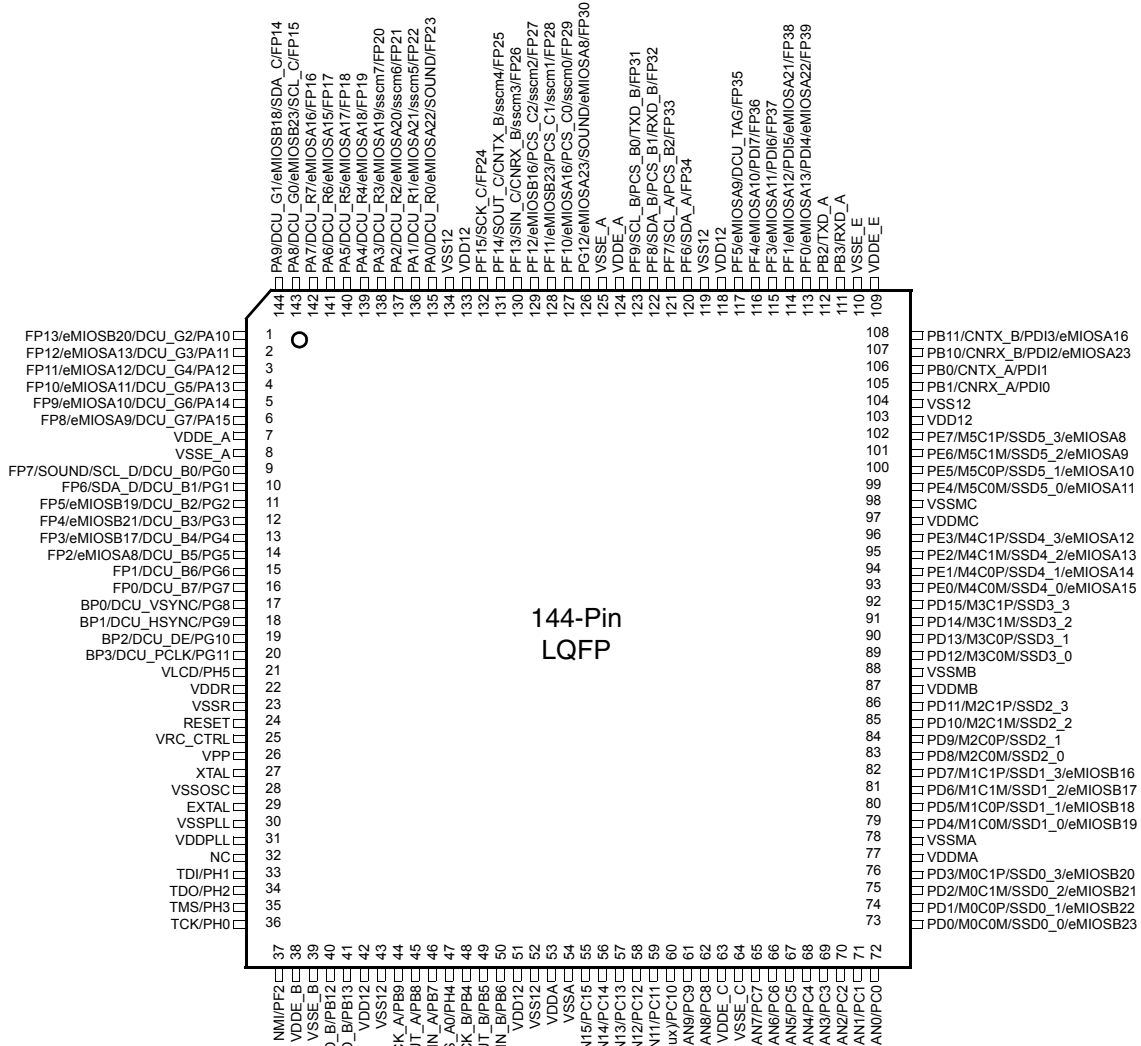

Figure 2. 144-pin LQFP Pinout

## 2.2 176 LQFP Package Pinout

Figure 3 shows the pinout for the 176-pin LQFP package.

### WARNING

Any pins labeled “NC” must not be connected to any external circuit.

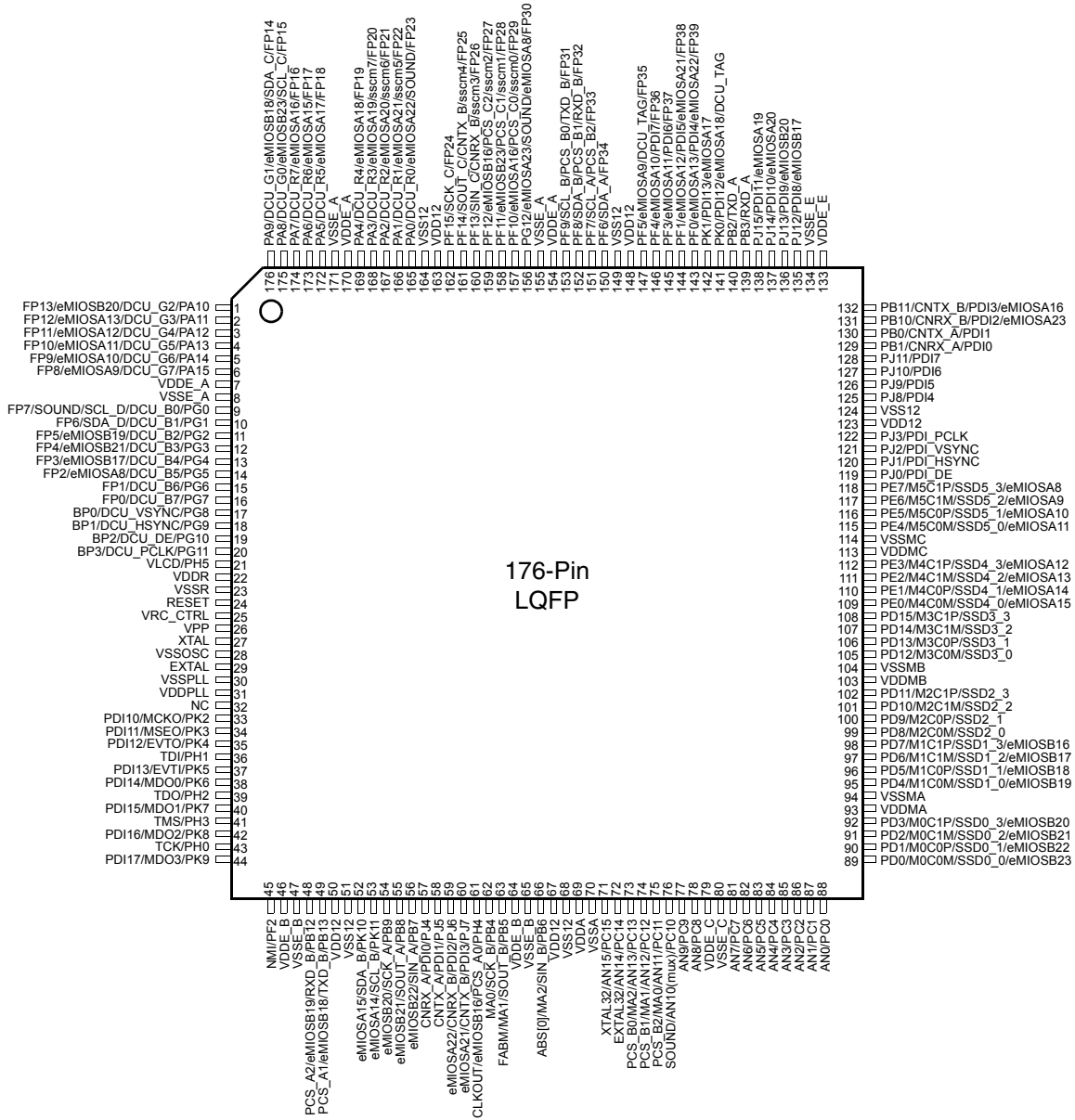

Figure 3. 176-pin LQFP Pinout

## 2.3 208 MAPBGA Package Pinout

Figure 4 shows the pinout for the 208-pin BGA package.

**WARNING**

Any pins labeled “NC” must not be connected to any external circuit.

	1	2	3	4	5	6	7	8	9	10	11	12	13	14	15	16																
A	PA0	PJ0	PJ1	PJ3	PJ5	PJ7	PJ14	PF0	PF5	PK9	PK5	NC	NC	PF10	PF11	PF12																
B	PA1	VDDE_A	PJ2	PJ4	PJ6	PJ8	PJ15	PF1	PF6	NC	PK6	PK2	NC	NC	VDDE_E	PF13																
C	PA2	PA3	VDDE_A	PJ9	PJ10	PJ12	PK0	PF3	PF7	NC	PK7	PK3	NC	VDDE_E	NC	PF14																
D	PA4	PA5	PG0	VDD12	PJ11	PJ13	PK1	PF4	VDD12	PG12	PK8	PK4	VDD12	NC	NC	PF15																
E	PA6	PA7	PG1	PG2	<table border="1" style="margin: auto;"> <tr><td>VSS</td><td>VSS</td><td>VSS</td><td>VSS</td></tr> <tr><td>VSS</td><td>VSS</td><td>VSS</td><td>VSS</td></tr> <tr><td>VSS</td><td>VSS</td><td>VSS</td><td>VSS</td></tr> <tr><td>VSS</td><td>VSS</td><td>VSS</td><td>VSS</td></tr> </table>								VSS	VSS	VSS	VSS	VSS	VSS	VSS	VSS	VSS	VSS	VSS	VSS	VSS	VSS	VSS	VSS	NC	NC	NC	NC
VSS	VSS	VSS	VSS																													
VSS	VSS	VSS	VSS																													
VSS	VSS	VSS	VSS																													
VSS	VSS	VSS	VSS																													
F	PA8	PA9	PG3	PG4									NC	NC	NC	NC																
G	PA10	PA11	PG5	PG6									NC	PE7	PE1	NC																
H	PA12	PA13	PA15	PG7									PE5	PE6	VDDMC	VSSMC																
J	RESET	PA14	PG8	PG10									PE4	PE2	PE0	PD8																
K	EXTAL	VDDE_A	PG9	PG11									PE3	PD13	PD9	PD7																
L	VSSPLL	VDDPLL	NMI/PF2	MDO3	PD15	PD12	VDDMB	VSSMB																								
M	XTAL	VPP	PH3	VREG BYPASS	PD14	PD11	PD5	PD6																								
N	VDDR	VLCD	PH2	VDD12	PK11	PK10	PB8	PB5	PC13	PC9	PC6	PB11	VDDMA	PD10	PD4	PD3																
P	VRC_CTRL	PH1	VDDE_B	MDO2	MDO1	PB13	PB7	PB4	PC12	PC8	PC5	PC3	PB10	NC	PD2	PD1																
R	PH0	VDDE_B	EVTO	PF9	PH4	PB12	PB6	PC15	PC11	PC7	PC4	PC2	PB3	PB2	VDDE_B	PD0																
T	MCKO	MSEO	EVTI	PF8	MDO0	PB9	VDDE_C	PC14	PC10	VSSA	VDDA	PC1	PC0	PB1	PB0	VSSMA																

Figure 4. 208-pin MAPBGA Pinout

**2.4 Signal Description**

The following sections provide signal descriptions and related information about the functionality and configuration.

## 2.4.1 Pad Configuration during Reset Phases

All pads have a fixed configuration under reset.

During the power-up phase, all pads are forced to tristate.

After power-up phase, all pads are floating with the following exceptions:

- Analog input pins AN[0:9] are pull-up
- EVTI (208-pin package only) is pull-up.
- PB[6] (FAB) is pull-up. Without external strong pull-up the device starts fetching from flash
- RESET pad is driven low. This is released only after PHASE2 reset completion.
- Main oscillator pads (EXTAL, XTAL) are tristate.
- PA[0] DCU\_R0 is pull-up
- PB[1] CNRX\_A is pull-up
- PB[10] CNRX\_B is pull-up
- PB[12] RXD\_B is pull-up
- PB[3] RXD\_A is pull-up
- PB[4] SCK\_B is pull-up
- PF[0] eMIOA13 is pull-up
- PF[11] eMIOB23 is pull-up
- PF[13] SIN\_C is pull-up
- PF[2] NMI is pull-up
- PF[3] eMIOA11 is pull-up
- PF[5] eMIOA9 is pull-up
- PF[6] SDA\_A is pull-up
- PF[8] SDA\_B is pull-up
- PH[0] TCK is pull-up
- PH[1] TDI is pull-up
- PH[3] TMS is pull-up
- PJ[4] PDI0 is pull-up
- PJ[6] PDI2 is pull-up
- PK[9] MDO3 is pull-up

## 2.4.2 Voltage Supply Pins

Voltage supply pins are used to provide power to the device. Two dedicated pins are used for 1.2 V regulator stabilization.

Table 3. Voltage Supply Pin Descriptions

Supply pin	Function	Pin Number		
		144 LQFP	176 LQFP	208 MAPBGA
$V_{DD12}^1$	1.2 V core supply (1.08 V - 1.32 V)	42, 51, 103, 118, 133	50, 67, 123, 148, 163	D4, D9, D13, N4
$V_{SS12}$	Low voltage ground for core domain	43, 52, 104, 119, 134	51, 68, 124, 149, 164	—
$V_{SS}$	Low voltage ground	—	—	G7, G8, G9, G10, H7, H8, H9, H10, J7, J8, J9, J10, K7, K8, K9, K10
$V_{DDA}$	3.3 V/5 V reference voltage and analog supply for A/D converter	53	69	T11
$V_{SSA}$	Reference ground and analog ground for A/D converter	54	70	T10
$V_{DDR}$	Voltage regulator VREG supply	22	22	N1
$V_{SSR}$	Voltage regulator ground	23	23	—
$V_{DDE\_A}$	3.3 V/5 V I/O supply. This supply is shared with internal flash and 16 MHz IRC oscillator.	7, 124	7, 154, 170	B2, C3, K2
$V_{SSE\_A}$	3.3 V/5 V I/O supply ground	8, 125	8, 155, 171	—
$V_{DDE\_B}$	3.3 V/5 V I/O supply. 4-16 MHz crystal oscillator shares this supply.	38	46, 64	P3, R2, R15
$V_{SSE\_B}$	3.3 V/5 V I/O supply ground	39	47, 65	—
$V_{DDE\_C}$	3.3 V/5 V I/O supply. 32 KHz oscillator shares this supply with ADC.	63	79	T7
$V_{SSE\_C}$	3.3 V/5 V I/O supply ground	64	80	—
$V_{DDE\_E}$	3.3 V/5 V I/O supply	109	133	B15, C14
$V_{SSE\_E}$	3.3 V/5 V I/O supply ground	110	134	—
$V_{DDMA}^2$	Stepper motor 5 V pad supply. SSD shares this supply.	77	93	N13
$V_{SSMA}$	Stepper motor ground	78	94	T16
$V_{DDMB}^2$	Stepper motor 5 V pad supply. SSD shares this supply.	87	103	L15
$V_{SSMB}$	Stepper motor ground	88	104	L16
$V_{DDMC}^2$	Stepper motor 5 V pad supply. SSD shares this supply.	97	113	H15
$V_{SSMC}$	Stepper motor ground	98	114	H16
$V_{DDPLL}$	1.2 V PLL supply	31	31	L2

Table 3. Voltage Supply Pin Descriptions (continued)

Supply pin	Function	Pin Number		
		144 LQFP	176 LQFP	208 MAPBGA
V <sub>SSPLL</sub>	PLL ground	30	30	L1
V <sub>SSOSC</sub>	Oscillator ground	28	28	—
V <sub>LCD</sub> <sup>3</sup>	LCD supply option	21	21	N2
V <sub>PP</sub> <sup>4</sup>	9 V - 12 V flash test analog write signal	26	26	M2

<sup>1</sup> Decoupling capacitors must be connected between these pins and the nearest V<sub>SS12</sub> pin.

<sup>2</sup> All stepper motor supplies need to be at same level (3.3 V or 5 V).

<sup>3</sup> Refer to LCD segment of Reference manual for usage of VLCD as supply/reference voltage source.

<sup>4</sup> This signal needs to be connected to ground during normal operation.

### 2.4.3 Pad Types

In the device the following types of pads are available for system pins and functional port pins:

S = Slow<sup>1</sup>

M = Medium<sup>1,2</sup>

F = Fast<sup>1,2</sup>

I = Input only with analog feature<sup>1</sup>

J = Input/Output with analog feature

X = Oscillator

### 2.4.4 System Pins

The system pins are listed in [Table 4](#).

1. Refer to [Section 3.6, "I/O Pad Electrical Characteristics](#), for details

2. All medium and fast pads are in slow configuration by default at reset and can be configured as fast or medium (refer to PCR.SRC in the device reference manual, Pad Configuration Registers (PCR0 - PCR120)).

Table 4. System Pin Descriptions

System pin	Function	I/O direction	Pad type	RESET configuration	Pin Number		
					144 LQFP	176 LQFP	208 MAPBGA
$\overline{\text{RESET}}$	Bidirectional reset with Schmitt-Trigger characteristics and noise filter.	I/O	M	Input, weak pull up	24	24	J1
EXTAL	Analog output of the oscillator amplifier circuit. Input for the clock generator in bypass mode.	O	X	—	29	29	K1
XTAL	Analog input of the oscillator amplifier circuit. Needs to be grounded if oscillator bypass mode is used.	I	X	—	27	27	M1
EXTAL32	Analog input of the 32KHz oscillator amplifier circuit.	O		—	56	72	—
XTAL32	Analog output of the 32 KHz oscillator amplifier circuit. Input for the clock generator in bypass mode.	I		—	55	71	—
NMI	Non-Maskable Interrupt	I/O		Input, weak pull up	37	45	L3
VRC_CTRL	Voltage Regulator external NPN Ballast base control pin			—	25	25	P1

## 2.4.5 Nexus Pins

Table 5. Nexus Pins

System pin	Function	Pin Number		
		144 LQFP	176 LQFP	208 MAPBGA
$\overline{\text{EVTI}}$	Nexus Event In	—	37	T3
$\overline{\text{EVTO}}$	Nexus Event Out	—	35	R3
MCKO	Nexus Msg Clock Out	—	33	T1
MDO[0]	Nexus Msg Data Out	—	38	T5



Table 5. Nexus Pins (continued)

System pin	Function	Pin Number		
		144 LQFP	176 LQFP	208 MAPBGA
MDO[1]	Nexus Msg Data Out	—	40	P5
MDO[2]	Nexus Msg Data Out	—	42	P4
MDO[3]	Nexus Msg Data Out	—	44	L4
$\overline{\text{MSE0}}$	Nexus Msg Start/End Out	—	34	T2

## 2.4.6 Functional Ports A, B, C, D, E, F, G, H, I, J, K

The functional port pins are listed in [Table 6](#).

**Table 6. Port Pin Summary**

Port Pin	PCR Register	Alternate Function <sup>1</sup>	Function	Special Function	Peripheral	I/O Direction	Pad Type <sup>2</sup>	RESET Config. <sup>3</sup>	Pin Number		
									144 LQFP	176 LQFP	208 MAPBGA
PA[0]	PCR[0]	Option 0 Option 1 Option 2 Option 3	GPIO[0] DCU_R0 eMIOSA[[22] SOUND	FP23	SIU DCU PWM/Timer Sound	I/O	M	Input, Pull Up	135	165	A1
PA[1]	PCR[1]	Option 0 Option 1 Option 2 Option 3	GPIO[1] DCU_R1 eMIOSA[21] —	FP22	SIU DCU PWM/Timer —	I/O	M	None, None	136	166	B1
PA[2]	PCR[2]	Option 0 Option 1 Option 2 Option 3	GPIO[2] DCU_R2 eMIOSA[20] —	FP21	SIU DCU PWM/Timer —	I/O	M	None, None	137	167	C1
PA[3]	PCR[3]	Option 0 Option 1 Option 2 Option 3	GPIO[3] DCU_R3 eMIOSA[19] —	FP20	SIU DCU PWM/Timer —	I/O	M	None, None	138	168	C2
PA[4]	PCR[4]	Option 0 Option 1 Option 2 Option 3	GPIO[4] DCU_R4 eMIOSA[18] —	FP19	SIU DCU PWM/Timer —	I/O	M	None, None	139	169	D1
PA[5]	PCR[5]	Option 0 Option 1 Option 2 Option 3	GPIO[5] DCU_R5 eMIOSA[17] —	FP18	SIU DCU PWM/Timer —	I/O	M	None, None	140	172	D2
PA[6]	PCR[6]	Option 0 Option 1 Option 2 Option 3	GPIO[6] DCU_R6 eMIOSA[15] —	FP17	SIU DCU PWM/Timer —	I/O	M	None, None	141	173	E1
PA[7]	PCR[7]	Option 0 Option 1 Option 2 Option 3	GPIO[7] DCU_R7 eMIOSA[16] —	FP16	SIU DCU PWM/Timer —	I/O	M	None, None	142	174	E2

**Table 6. Port Pin Summary (continued)**

Port Pin	PCR Register	Alternate Function <sup>1</sup>	Function	Special Function	Peripheral	I/O Direction	Pad Type <sup>2</sup>	RESET Config. <sup>3</sup>	Pin Number		
									144 LQFP	176 LQFP	208 MAPBGA
PA[8]	PCR[8]	Option 0 Option 1 Option 2 Option 3	GPIO[8] DCU_G0 eMIOSB[23] SCL_C	FP15	SIU DCU PWM/Timer I <sup>2</sup> C_2	I/O	M	None, None	143	175	F1
PA[9]	PCR[9]	Option 0 Option 1 Option 2 Option 3	GPIO[9] DCU_G1 eMIOSB[18] SDA_C	FP14	SIU DCU PWM/Timer I <sup>2</sup> C_2	I/O	M	None, None	144	176	F2
PA[10]	PCR[10]	Option 0 Option 1 Option 2 Option 3	GPIO[10] DCU_G2 eMIOSB[20] —	FP13	SIU DCU PWM/Timer —	I/O	M	None, None	1	1	G1
PA[11]	PCR[11]	Option 0 Option 1 Option 2 Option 3	GPIO[11] DCU_G3 eMIOSA[13] —	FP12	SIU DCU PWM/Timer —	I/O	M	None, None	2	2	G2
PA[12]	PCR[12]	Option 0 Option 1 Option 2 Option 3	GPIO[12] DCU_G4 eMIOSA[12] —	FP11	SIU DCU PWM/Timer —	I/O	M	None, None	3	3	H1
PA[13]	PCR[13]	Option 0 Option 1 Option 2 Option 3	GPIO[13] DCU_G5 eMIOSA[11] —	FP10	SIU DCU PWM/Timer —	I/O	M	None, None	4	4	H2
PA[14]	PCR[14]	Option 0 Option 1 Option 2 Option 3	GPIO[14] DCU_G6 eMIOSA[10] —	FP9	SIU DCU PWM/Timer —	I/O	M	None, None	5	5	J2
PA[15]	PCR[15]	Option 0 Option 1 Option 2 Option 3	GPIO[15] DCU_G7 eMIOSA[9] —	FP8	SIU DCU PWM/Timer —	I/O	M	None, None	6	6	H3

Table 6. Port Pin Summary (continued)

Port Pin	PCR Register	Alternate Function <sup>1</sup>	Function	Special Function	Peripheral	I/O Direction	Pad Type <sup>2</sup>	RESET Config. <sup>3</sup>	Pin Number		
									144 LQFP	176 LQFP	208 MAPBGA
PB[0]	PCR[16]	Option 0 Option 1 Option 2 Option 3	GPIO[16] CANTX_A PDI1 —	—	SIU CAN-A PDI —	I/O	M	None, None	106	130	T15
PB[1]	PCR[17]	Option 0 Option 1 Option 2 Option3	GPIO[17] CANRX_A PDI0 —	—	SIU CAN-A PDI —	I/O	S	Input, Pull Up	105	129	T14
PB[2]	PCR[18]	Option 0 Option 1 Option 2 Option3	GPIO[18] TXD_A — —	—	SIU LIN_A — —	I/O	S	None, None	112	140	R14
PB[3]	PCR[19]	Option 0 Option 1 Option 2 Option3	GPIO[19] RXD_A — —	—	SIU LIN_A — —	I/O	S	Input, Pull Up	111	139	R13
PB[4]	PCR[20]	Option 0 Option 1 Option 2 Option 3	GPIO[20] SCK_B MA0 —	—	SIU SPI_1 ADC —	I/O	M	Input, Pull Up	48	62	P8
PB[5]	PCR[21]	Option 0 Option 1 Option 2 Option 3	GPIO[21] SOUT_B MA1 FABM	—	SIU SPI_1 ADC Control	I/O	M	Input, Pull Down	49	63	N8
PB[6]	PCR[22]	Option 0 Option 1 Option 2 Option 3	GPIO[22] SIN_B MA2 ABS[0]	—	SIU SPI_1 ADC Control	I/O	S	Input, Pull Up	50	66	R7
PB[7]	PCR[23]	Option 0 Option 1 Option 2 Option 3	GPIO[23] SIN_A eMIOSB[22] —	—	SIU SPI_A PWM/Timer —	I/O	S	None, None	46	56	P7

Table 6. Port Pin Summary (continued)

Port Pin	PCR Register	Alternate Function <sup>1</sup>	Function	Special Function	Peripheral	I/O Direction	Pad Type <sup>2</sup>	RESET Config. <sup>3</sup>	Pin Number		
									144 LQFP	176 LQFP	208 MAPBGA
PB[8]	PCR[24]	Option 0 Option 1 Option 2 Option 3	GPIO[24] SOUT_A eMIOSB[21] —	—	SIU SPI_A PWM/Timer —	I/O	M	None, None	45	55	N7
PB[9]	PCR[25]	Option 0 Option 1 Option 2 Option 3	GPIO[25] SCK_A eMIOSB[20] —	—	SIU SPI_A PWM/Timer —	I/O	M	Input, Pull Up	44	54	T6
PB[10]	PCR[26]	Option 0 Option 1 Option 2 Option 3	GPIO[26] CNRX_B PDI2 eMIOA[23]	—	SIU CAN-B PDI PWM/Timer	I/O	S	Input, Pull Up	107	131	P13
PB[11]	PCR[27]	Option 0 Option 1 Option 2 Option 3	GPIO[27] CNTX_B PDI3 eMIOA[16]	—	SIU CAN-B PDI PWM/Timer	I/O	M	None, None	108	132	N12
PB[12]	PCR[28]	Option 0 Option 1 Option 2 Option 3	GPIO[28] RXD_B eMIOSB[19] PCS_A2	—	SIU LIN_B PWM/Timer SPI_0	I/O	S	Input, Pull Up	40	48	R6
PB[13]	PCR[29]	Option 0 Option 1 Option 2 Option 3	GPIO[29] TXD_B eMIOSB[18] PCS_A1	—	SIU LIN_B PWM/Timer SPI_0	I/O	S	None, None	41	49	P6
PB[14]	—	—	Reserved	—	—	—	—	—	—	—	A11
PB[15]	—	—	Reserved	—	—	—	—	—	—	—	—
PC[0]	PCR[30]	Option 0 Option 1 Option 2 Option 3	GPIO[30] AN[0] — —	—	SIU ADC — —	I	A	Input, Pull Up	72	88	T13
PC[1]	PCR[31]	Option 0 Option 1 Option 2 Option 3	GPIO[31] AN[1] — —	—	SIU ADC — —	I	A	Input, Pull Up	71	87	T12

Table 6. Port Pin Summary (continued)

Port Pin	PCR Register	Alternate Function <sup>1</sup>	Function	Special Function	Peripheral	I/O Direction	Pad Type <sup>2</sup>	RESET Config. <sup>3</sup>	Pin Number		
									144 LQFP	176 LQFP	208 MAPBGA
PC[2]	PCR[32]	Option 0 Option 1 Option 2 Option 3	GPIO[32] AN[2] — —	—	SIU ADC — —	I	A	Input, Pull Up	70	86	R12
PC[3]	PCR[33]	Option 0 Option 1 Option 2 Option 3	GPIO[33] AN[3] — —	—	SIU ADC — —	I	A	Input, Pull Up	69	85	P12
PC[4]	PCR[34]	Option 0 Option 1 Option 2 Option 3	GPIO[34] AN[4] — —	—	SIU ADC — —	I	A	Input, Pull Up	68	84	R11
PC[5]	PCR[35]	Option 0 Option 1 Option 2 Option 3	GPIO[35] AN[5] — —	—	SIU ADC — —	I	A	Input, Pull Up	67	83	P11
PC[6]	PCR[36]	Option 0 Option 1 Option 2 Option 3	GPIO[36] AN[6] — —	—	SIU ADC — —	I	A	Input, Pull Up	66	82	N11
PC[7]	PCR[37]	Option 0 Option 1 Option 2 Option 3	GPIO[37] AN[7] — —	—	SIU ADC — —	I	A	Input, Pull Up	65	81	R10
PC[8]	PCR[38]	Option 0 Option 1 Option 2 Option 3	GPIO[38] AN[8] — —	—	SIU ADC — —	I	A	Input, Pull Up	62	78	P10
PC[9]	PCR[39]	Option 0 Option 1 Option 2 Option 3	GPIO[39] AN[9] — —	—	SIU ADC — —	I	A	Input, Pull Up	61	77	N10

Table 6. Port Pin Summary (continued)

Port Pin	PCR Register	Alternate Function <sup>1</sup>	Function	Special Function	Peripheral	I/O Direction	Pad Type <sup>2</sup>	RESET Config. <sup>3</sup>	Pin Number		
									144 LQFP	176 LQFP	208 MAPBGA
PC[10]	PCR[40]	Option 0 Option 1 Option 2 Option 3	GPIO[40] AN[10] SOUND —	—	SIU ADC Sound —	I/O	S	Input, Pull Up	60	76	T9
PC[11]	PCR[41]	Option 0 Option 1 Option 2 Option 3	GPIO[41] AN[11] MA0 PCS_B2	—	SIU ADC ADC SPI_B	I/O	S	None, None	59	75	R9
PC[12]	PCR[42]	Option 0 Option 1 Option 2 Option 3	GPIO[42] AN[12] MA1 PCS_B1	—	SIU ADC ADC SPI_B	I/O	S	None, None	58	74	P9
PC[13]	PCR[43]	Option 0 Option 1 Option 2 Option 3	GPIO[43] AN[13] MA2 PCS_B0	—	SIU ADC ADC SPI_B	I/O	S	None, None	57	73	N9
PC[14]	PCR[44]	Option 0 Option 1 Option 2 Option 3	GPIO[44] AN[14] EXTAL32 —	—	SIU ADC Osc —	I/O	S	None, None	56	72	T8
PC[15]	PCR[45]	Option 0 Option 1 Option 2 Option 3	GPIO[45] AN[15] XTAL32 —	—	SIU ADC Osc —	I/O	S	None, None	55	71	R8
PD[0]	PCR[46]	Option 0 Option 1 Option 2 Option 3	GPIO[46] M0C0M SSD0_0 eMIOSB[23]	—	SIU SMD SSD PWM/Timer	I/O	SMD	None, None	73	89	R16
PD[1]	PCR[47]	Option 0 Option 1 Option 2 Option 3	GPIO[47] M0C0P SSD0_1 eMIOSB[22]	—	SIU SMD SSD PWM/Timer	I/O	SMD	None, None	74	90	P16

Table 6. Port Pin Summary (continued)

Port Pin	PCR Register	Alternate Function <sup>1</sup>	Function	Special Function	Peripheral	I/O Direction	Pad Type <sup>2</sup>	RESET Config. <sup>3</sup>	Pin Number		
									144 LQFP	176 LQFP	208 MAPBGA
PD[2]	PCR[48]	Option 0 Option 1 Option 2 Option 3	GPIO[48] M0C1M SSD0_2 eMIO SB[21]	—	SIU SMD SSD PWM/Timer	I/O	SMD	None, None	75	91	P15
PD[3]	PCR[49]	Option 0 Option 1 Option 2 Option 3	GPIO[49] M0C1P SSD0_3 eMIO SB[20]	—	SIU SMD SSD PWM/Timer	I/O	SMD	None, None	76	92	N16
PD[4]	PCR[50]	Option 0 Option 1 Option 2 Option 3	GPIO[50] M1C0M SSD1_0 eMIO SB[19]	—	SIU SMD SSD PWM/Timer	I/O	SMD	None, None	79	95	N15
PD[5]	PCR[51]	Option 0 Option 1 Option 2 Option 3	GPIO[51] M1C0P SSD1_1 eMIO SB[18]	—	SIU SMD SSD PWM/Timer	I/O	SMD	None, None	80	96	M15
PD[6]	PCR[52]	Option 0 Option 1 Option 2 Option 3	GPIO[52] M1C1M SSD1_2 eMIO SB[17]	—	SIU SMD SSD PWM/Timer	I/O	SMD	None, None	81	97	M16
PD[7]	PCR[53]	Option 0 Option 1 Option 2 Option 3	GPIO[53] M1C1P SSD1_3 eMIO SB[16]	—	SIU SMD SSD PWM/Timer	I/O	SMD	None, None	82	98	K16
PD[8]	PCR[54]	Option 0 Option 1 Option 2 Option 3	GPIO[54] M2C0M SSD2_0 —	—	SIU SMD SSD —	I/O	SMD	None, None	83	99	J16
PD[9]	PCR[55]	Option 0 Option 1 Option 2 Option 3	GPIO[55] M2C0P SSD2_1 —	—	SIU SMD SSD —	I/O	SMD	None, None	84	100	K15



Table 6. Port Pin Summary (continued)

Port Pin	PCR Register	Alternate Function <sup>1</sup>	Function	Special Function	Peripheral	I/O Direction	Pad Type <sup>2</sup>	RESET Config. <sup>3</sup>	Pin Number		
									144 LQFP	176 LQFP	208 MAPBGA
PD[10]	PCR[56]	Option 0 Option 1 Option 2 Option 3	GPIO[56] M2C1M SSD2_2 —	—	SIU SMD SSD —	I/O	SMD	None, None	85	101	N14
PD[11]	PCR[57]	Option 0 Option 1 Option 2 Option 3	GPIO[57] M2C1P SSD2_3 —	—	SIU SMD SSD —	I/O	SMD	None, None	86	102	M14
PD[12]	PCR[58]	Option 0 Option 1 Option 2 Option 3	GPIO[58] M3C0M SSD3_0 —	—	SIU SMD SSD —	I/O	SMD	None, None	89	105	L14
PD[13]	PCR[59]	Option 0 Option 1 Option 2 Option 3	GPIO[59] M3C0P SSD3_1 —	—	SIU SMD SSD —	I/O	SMD	None, None	90	106	K14
PD[14]	PCR[60]	Option 0 Option 1 Option 2 Option 3	GPIO[60] M3C1M SSD3_2 —	—	SIU SMD SSD —	I/O	SMD	None, None	91	107	M13
PD[15]	PCR[61]	Option 0 Option 1 Option 2 Option 3	GPIO[61] M3C1P SSD3_3 —	—	SIU SMD SSD —	I/O	SMD	None, None	92	108	L13
PE[0]	PCR[62]	Option 0 Option 1 Option 2 Option 3	GPIO[62] M4C0M SSD4_0 eMIOSA[15]	—	SIU SMD SSD PWM/Timer	I/O	SMD	None, None	93	109	J15
PE[1]	PCR[63]	Option 0 Option 1 Option 2 Option 3	GPIO[63] M4C0P SSD4_1 eMIOSA[14]	—	SIU SMD SSD PWM/Timer	I/O	SMD	None, None	94	110	G15

Table 6. Port Pin Summary (continued)

Port Pin	PCR Register	Alternate Function <sup>1</sup>	Function	Special Function	Peripheral	I/O Direction	Pad Type <sup>2</sup>	RESET Config. <sup>3</sup>	Pin Number		
									144 LQFP	176 LQFP	208 MAPBGA
PE[2]	PCR[64]	Option 0 Option 1 Option 2 Option 3	GPIO[64] M4C1M SSD4_2 eMIOA[13]	—	SIU SMD SSD PWM/Timer	I/O	SMD	None, None	95	111	J14
PE[3]	PCR[65]	Option 0 Option 1 Option 2 Option 3	GPIO[65] M4C1P SSD4_3 eMIOA[12]	—	SIU SMD SSD PWM/Timer	I/O	SMD	None, None	96	112	K13
PE[4]	PCR[66]	Option 0 Option 1 Option 2 Option 3	GPIO[66] M5C0M SSD5_0 eMIOA[11]	—	SIU SMD SSD PWM/Timer	I/O	SMD	None, None	99	115	J13
PE[5]	PCR[67]	Option 0 Option 1 Option 2 Option 3	GPIO[67] M5C0P SSD5_1 eMIOA[10]	—	SIU SMD SSD PWM/Timer	I/O	SMD	None, None	100	116	H13
PE[6]	PCR[68]	Option 0 Option 1 Option 2 Option 3	GPIO[68] M5C1M SSD5_2 eMIOA[9]	—	SIU SMD SSD PWM/Timer	I/O	SMD	None, None	101	117	H14
PE[7]	PCR[69]	Option 0 Option 1 Option 2 Option 3	GPIO[69] M5C1P SSD5_3 eMIOA[8]	—	SIU SMD SSD PWM/Timer	I/O	SMD	None, None	102	118	G14
PE[8]	—	—	Reserved	—	—	—	—	—	—	—	—
PE[9]	—	—	Reserved	—	—	—	—	—	—	—	—
PE[10]	—	—	Reserved	—	—	—	—	—	—	—	—
PE[11]	—	—	Reserved	—	—	—	—	—	—	—	—
PE[12]	—	—	Reserved	—	—	—	—	—	—	—	—
PE[13]	—	—	Reserved	—	—	—	—	—	—	—	—
PE[14]	—	—	Reserved	—	—	—	—	—	—	—	—
PE[15]	—	—	Reserved	—	—	—	—	—	—	—	—

Table 6. Port Pin Summary (continued)

Port Pin	PCR Register	Alternate Function <sup>1</sup>	Function	Special Function	Peripheral	I/O Direction	Pad Type <sup>2</sup>	RESET Config. <sup>3</sup>	Pin Number		
									144 LQFP	176 LQFP	208 MAPBGA
PF[0]	PCR[70]	Option 0 Option 1 Option 2 Option 3	GPIO[70] eMIOSA[13] PDI4 eMIOSA[22]	FP39	SIU PWM/Timer PDI PWM/Timer	I/O	S	Input, Pull Up	113	143	A8
PF[1]	PCR[71]	Option 0 Option 1 Option 2 Option 3	GPIO[71] eMIOSA[12] PDI5 eMIOSA[21]	FP38	SIU PWM/Timer PDI PWM/Timer	I/O	S	None, None	114	144	B8
PF[2]	PCR[72]	Option 0 Option 1 Option 2 Option 3	GPIO[72] NMI — —	—	SIU NMI — —	I/O	S	Input, Pull Up	37	45	L3
PF[3]	PCR[73]	Option 0 Option 1 Option 2 Option 3	GPIO[73] eMIOSA[11] PDI6 —	FP37	SIU PWM/Timer PDI —	I/O	M	Input, Pull Up	115	145	C8
PF[4]	PCR[74]	Option 0 Option 1 Option 2 Option 3	GPIO[74] eMIOSA[10] PDI7 —	FP36	SIU PWM/Timer PDI —	I/O	M	None, None	116	146	D8
PF[5]	PCR[75]	Option 0 Option 1 Option 2 Option 3	GPIO[75] eMIOSA[9] DCU_TAG —	FP35	SIU PWM/Timer DCU —	I/O	M	Input, Pull Up	117	147	A9
PF[6]	PCR[76]	Option 0 Option 1 Option 2 Option 3	GPIO[76] SDA_A — —	FP34	SIU I <sup>2</sup> C_A — —	I/O	S	Input, Pull Up	120	150	B9
PF[7]	PCR[77]	Option 0 Option 1 Option 2 Option 3	GPIO[77] SCL_A PCS_B2 —	FP33	SIU I <sup>2</sup> C_A SPI_B —	I/O	S	None, None	121	151	C9

Table 6. Port Pin Summary (continued)

Port Pin	PCR Register	Alternate Function <sup>1</sup>	Function	Special Function	Peripheral	I/O Direction	Pad Type <sup>2</sup>	RESET Config. <sup>3</sup>	Pin Number		
									144 LQFP	176 LQFP	208 MAPBGA
PF[8]	PCR[78]	Option 0 Option 1 Option 2 Option 3	GPIO[78] SDA_B PCS_B1 RXD_B	FP32	SIU I <sup>2</sup> C_B SPI_B LIN_B	I/O	S	Input, Pull Up	122	152	T4
PF[9]	PCR[79]	Option 0 Option 1 Option 2 Option 3	GPIO[79] SCL_B PCS_B0 TXD_B	FP31	SIU I <sup>2</sup> C_B SPI_B LIN_B	I/O	S	None, None	123	153	R4
PF[10]	PCR[80]	Option 0 Option 1 Option 2 Option 3	GPIO[80] eMIOSA[16] PCS_C0 —	FP29	SIU PWM/Timer SPI_C —	I/O	M	None, None	127	157	A14
PF[11]	PCR[81]	Option 0 Option 1 Option 2 Option 3	GPIO[81] eMIOSB[23] PCS_C1 —	FP28	SIU PWM/Timer SPI_C —	I/O	M	Input, Pull Up	128	158	A15
PF[12]	PCR[82]	Option 0 Option 1 Option 2 Option 3	GPIO[82] eMIOSB[16] PCS_C2 —	FP27	SIU PWM/Timer SPI_C —	I/O	M	None, None	129	159	A16
PF[13]	PCR[83]	Option 0 Option 1 Option 2 Option 3	GPIO[83] SIN_C CNRX_B —	FP26	SIU SPI_C CAN_B —	I/O	M	Input, Pull Up	130	160	B16
PF[14]	PCR[84]	Option 0 Option 1 Option 2 Option 3	GPIO[84] SOUT_C CANTX_B —	FP25	SIU SPI_C CAN_B —	I/O	M	None, None	131	161	C16
PF[15]	PCR[85]	Option 0 Option 1 Option 2 Option 3	GPIO[85] SCK_C — —	FP24	SIU SPI_C — —	I/O	F	None, None	132	162	D16

Table 6. Port Pin Summary (continued)

Port Pin	PCR Register	Alternate Function <sup>1</sup>	Function	Special Function	Peripheral	I/O Direction	Pad Type <sup>2</sup>	RESET Config. <sup>3</sup>	Pin Number		
									144 LQFP	176 LQFP	208 MAPBGA
PG[0]	PCR[86]	Option 0 Option 1 Option 2 Option 3	GPIO[86] DCU_B0 SCL_D SOUND	FP7	SIU DCU I <sup>2</sup> C_3 Sound	I/O	M	None, None	9	9	D3
PG[1]	PCR[87]	Option 0 Option 1 Option 2 Option 3	GPIO[87] DCU_B1 SDA_D —	FP6	SIU DCU I <sup>2</sup> C_3 —	I/O	M	None, None	10	10	E3
PG[2]	PCR[88]	Option 0 Option 1 Option 2 Option 3	GPIO[88] DCU_B2 eMIOSB[19] —	FP5	SIU DCU PWM/Timer —	I/O	M	None, None	11	11	E4
PG[3]	PCR[89]	Option 0 Option 1 Option 2 Option 3	GPIO[89] DCU_B3 eMIOSB[21] —	FP4	SIU DCU PWM/Timer —	I/O	M	None, None	12	12	F3
PG[4]	PCR[90]	Option 0 Option 1 Option 2 Option 3	GPIO[90] DCU_B4 eMIOSB[17] —	FP3	SIU DCU PWM/Timer —	I/O	M	None, None	13	13	F4
PG[5]	PCR[91]	Option 0 Option 1 Option 2 Option 3	GPIO[91] DCU_B5 eMIOSA[8] —	FP2	SIU DCU PWM/Timer —	I/O	M	None, None	14	14	G3
PG[6]	PCR[92]	Option 0 Option 1 Option 2 Option 3	GPIO[92] DCU_B6 — —	FP1	SIU DCU — —	I/O	M	None, None	15	15	G4
PG[7]	PCR[93]	Option 0 Option 1 Option 2 Option 3	GPIO[93] DCU_B7 — —	FP0	SIU DCU — —	I/O	M	None, None	16	16	H4

**Table 6. Port Pin Summary (continued)**

Port Pin	PCR Register	Alternate Function <sup>1</sup>	Function	Special Function	Peripheral	I/O Direction	Pad Type <sup>2</sup>	RESET Config. <sup>3</sup>	Pin Number		
									144 LQFP	176 LQFP	208 MAPBGA
PG[8]	PCR[94]	Option 0 Option 1 Option 2 Option 3	GPIO[94] DCU_VSYNC — —	BP0	SIU DCU — —	I/O	M	Input, Pull Up	17	17	J3
PG[9]	PCR[95]	Option 0 Option 1 Option 2 Option 3	GPIO[95] DCU_HSYNC — —	BP1	SIU DCU — —	I/O	M	Input, Pull Up	18	18	K3
PG[10]	PCR[96]	Option 0 Option 1 Option 2 Option 3	GPIO[96] DCU_DE — —	BP2	SIU DCU — —	I/O	M	None, None	19	19	J4
PG[11]	PCR[97]	Option 0 Option 1 Option 2 Option 3	GPIO[97] DCU_PCLK — —	BP3	SIU DCU — —	I/O	M	None, None	20	20	K4
PG[12]	PCR[98]	Option 0 Option 1 Option 2 Option 3	GPIO[98] eMIOA[23] SOUND eMIOA[8]	FP30	SIU PWM/Timer Sound PWM/Timer	I/O	S	None, None	126	156	D10
PG[13]	—	—	Reserved	—	—	—	—	—	—	—	—
PG[14]	—	—	Reserved	—	—	—	—	—	—	—	—
PG[15]	—	—	Reserved	—	—	—	—	—	—	—	—
PH[0] <sup>4</sup>	PCR[99]	Option 0 Option 1 Option 2 Option 3	GPIO[99] TCK — —	—	SIU JTAG — —	I/O	S	Input, Pull Up	36	43	R1
PH[1] <sup>4</sup>	PCR[100]	Option 0 Option 1 Option 2 Option 3	GPIO[100] TDI — —	—	SIU JTAG — —	I/O	S	Input, Pull Up	33	36	P2

Table 6. Port Pin Summary (continued)

Port Pin	PCR Register	Alternate Function <sup>1</sup>	Function	Special Function	Peripheral	I/O Direction	Pad Type <sup>2</sup>	RESET Config. <sup>3</sup>	Pin Number		
									144 LQFP	176 LQFP	208 MAPBGA
PH[2] <sup>4</sup>	PCR[101]	Option 0 Option 1 Option 2 Option 3	GPIO[101] TDO — —	—	SIU JTAG — —	I/O	M	Output, None	34	39	N3
PH[3] <sup>4</sup>	PCR[102]	Option 0 Option 1 Option 2 Option 3	GPIO[102] TMS — —	—	SIU JTAG — —	I/O	S	Input, Pull Up	35	41	M3
PH[4]	PCR[103]	Option 0 Option 1 Option 2 Option 3	GPIO[103] PCS_A0 eMIOSB[16] CLKOUT	—	SIU SPI_0 PWM/Timer Control	I/O	F	None, None	47	61	R5
PH[5]	PCR[104]	Option 0 Option 1 Option 2 Option 3	GPIO[104] VLCD — —	—	SIU LCD — —				21	21	—
PH[6]	—	—	Reserved	—	—	—	—	—	—	—	—
PH[7]	—	—	Reserved	—	—	—	—	—	—	—	—
PH[8]	—	—	Reserved	—	—	—	—	—	—	—	—
PH[9]	—	—	Reserved	—	—	—	—	—	—	—	—
PH[10]	—	—	Reserved	—	—	—	—	—	—	—	—
PH[11]	—	—	Reserved	—	—	—	—	—	—	—	—
PH[12]	—	—	Reserved	—	—	—	—	—	—	—	—
PH[13]	—	—	Reserved	—	—	—	—	—	—	—	—
PH[14]	—	—	Reserved	—	—	—	—	—	—	—	—
PH[15]	—	—	Reserved	—	—	—	—	—	—	—	—
PJ[0]	PCR[105]	Option 0 Option 1 Option 2 Option 3	GPIO[105] PDI_DE — —	—	SIU PDI — —	I/O	S	None, None	—	119	A2

Table 6. Port Pin Summary (continued)

Port Pin	PCR Register	Alternate Function <sup>1</sup>	Function	Special Function	Peripheral	I/O Direction	Pad Type <sup>2</sup>	RESET Config. <sup>3</sup>	Pin Number		
									144 LQFP	176 LQFP	208 MAPBGA
PJ[1]	PCR[106]	Option 0 Option 1 Option 2 Option 3	GPIO[106] PDI_HSYNC — —	—	SIU PDI — —	I/O	S	None, None	—	120	A3
PJ[2]	PCR[107]	Option 0 Option 1 Option 2 Option 3	GPIO[107] PDI_VSYNC — —	—	SIU PDI — —	I/O	S	None, None	—	121	B3
PJ[3]	PCR[108]	Option 0 Option 1 Option 2 Option 3	GPIO[108] PDI_PCLK — —	—	SIU PDI — —	I/O	M	None, None	—	122	A4
PJ[4]	PCR[109]	Option 0 Option 1 Option 2 Option 3	GPIO[109] PDI[0] CNRX_A —	—	SIU PDI CAN-A —	I/O	S	Input, Pull Up	—	57	B4
PJ[5]	PCR[110]	Option 0 Option 1 Option 2 Option 3	GPIO[110] PDI[1] CNTX_A —	—	SIU PDI CAN-A —	I/O	M	None, None	—	58	A5
PJ[6]	PCR[111]	Option 0 Option 1 Option 2 Option 3	GPIO[111] PDI[2] CNRX_B eMIOSA[22]	—	SIU PDI CAN-B PWM/Timer	I/O	S	Input, Pull Up	—	59	B5
PJ[7]	PCR[112]	Option 0 Option 1 Option 2 Option 3	GPIO[112] PDI[3] CNTX_B eMIOSA[21]	—	SIU PDI CAN-B PWM/Timer	I/O	M	None, None	—	60	A6
PJ[8]	PCR[113]	Option 0 Option 1 Option 2 Option 3	GPIO[113] PDI[4] — —	—	SIU PDI — —	I/O	S	None, None	—	125	B6



Table 6. Port Pin Summary (continued)

Port Pin	PCR Register	Alternate Function <sup>1</sup>	Function	Special Function	Peripheral	I/O Direction	Pad Type <sup>2</sup>	RESET Config. <sup>3</sup>	Pin Number		
									144 LQFP	176 LQFP	208 MAPBGA
PJ[9]	PCR[114]	Option 0 Option 1 Option 2 Option 3	GPIO[114] PDI[5] — —	—	SIU PDI — —	I/O	S	None, None	—	126	C4
PJ[10]	PCR[115]	Option 0 Option 1 Option 2 Option 3	GPIO[115] PDI[6] — —	—	SIU PDI — —	I/O	S	None, None	—	127	C5
PJ[11]	PCR[116]	Option 0 Option 1 Option 2 Option 3	GPIO[116] PDI[7] — —	—	SIU PDI — —	I/O	S	None, None	—	128	D5
PJ[12]	PCR[117]	Option 0 Option 1 Option 2 Option 3	GPIO[117] PDI[8] eMIO SB[17] —	—	SIU PDI PWM/Timer —	I/O	M	None, None	—	135	C6
PJ[13]	PCR[118]	Option 0 Option 1 Option 2 Option 3	GPIO[118] PDI[9] eMIO SB[20] —	—	SIU PDI PWM/Timer —	I/O	M	None, None	—	136	D6
PJ[14]	PCR[119]	Option 0 Option 1 Option 2 Option 3	GPIO[119] PDI[10] eMIO SA[20] —	—	SIU PDI PWM/Timer —	I/O	M	None, None	—	137	A7
PJ[15]	PCR[120]	Option 0 Option 1 Option 2 Option 3	GPIO[120] PDI[11] eMIO SA[19] —	—	SIU PDI PWM/Timer —	I/O	M	None, None	—	138	B7
PK[0]	PCR[121]	Option 0 Option 1 Option 2 Option 3	GPIO[121] PDI[12] eMIO SA[18] DCU_TAG	—	SIU PDI PWM/Timer DCU	I/O	M	None, None	—	141	C7

Table 6. Port Pin Summary (continued)

Port Pin	PCR Register	Alternate Function <sup>1</sup>	Function	Special Function	Peripheral	I/O Direction	Pad Type <sup>2</sup>	RESET Config. <sup>3</sup>	Pin Number		
									144 LQFP	176 LQFP	208 MAPBGA
PK[1]	PCR[122]	Option 0 Option 1 Option 2 Option 3	GPIO[122] PDI[13] eMIOSA[17] —	—	SIU PDI PWM/Timer —	I/O	M	None, None	—	142	D7
PK[2]	PCR[123]	Option 0 Option 1 Option 2 Option 3	GPIO[123] MCKO PDI[10] —	—	SIU Nexus PDI —	I/O	F	None, None	—	33	B12
PK[3]	PCR[124]	Option 0 Option 1 Option 2 Option 3	GPIO[124] MSEO PDI[11] —	—	SIU Nexus PDI —	I/O	M	None, None	—	34	C12
PK[4]	PCR[125]	Option 0 Option 1 Option 2 Option 3	GPIO[125] EVTO PDI[12] —	—	SIU Nexus PDI —	I/O	M	None, None	—	35	D12
PK[5]	PCR[126]	Option 0 Option 1 Option 2 Option 3	GPIO[126] EVTI PDI[13] —	—	SIU Nexus PDI —	I/O	M	None, None	—	37	—
PK[6]	PCR[127]	Option 0 Option 1 Option 2 Option 3	GPIO[127] MDO0 PDI[14] —	—	SIU Nexus PDI —	I/O	M	None, None	—	38	B11
PK[7]	PCR[128]	Option 0 Option 1 Option 2 Option 3	GPIO[128] MDO1 PDI[15] —	—	SIU Nexus PDI —	I/O	M	None, None	—	40	C11
PK[8]	PCR[129]	Option 0 Option 1 Option 2 Option 3	GPIO[129] MDO2 PDI[16] —	—	SIU Nexus PDI —	I/O	M	None, None	—	42	D11

Table 6. Port Pin Summary (continued)

Port Pin	PCR Register	Alternate Function <sup>1</sup>	Function	Special Function	Peripheral	I/O Direction	Pad Type <sup>2</sup>	RESET Config. <sup>3</sup>	Pin Number		
									144 LQFP	176 LQFP	208 MAPBGA
PK[9]	PCR[130]	Option 0 Option 1 Option 2 Option 3	GPIO[130] MDO3 PDI[17] —	—	SIU Nexus PDI —	I/O	M	Input, Pull Up	—	44	A10
PK[10]	PCR[131]	Option 0 Option 1 Option 2 Option 3	GPIO[131] SDA_B eMIOA[15] —	—	SIU I <sup>2</sup> C_B PWM/Timer —	I/O	S	None, None	—	52	N6
PK[11]	PCR[132]	Option 0 Option 1 Option 2 Option 3	GPIO[132] SCL_B eMIOA[14] —	—	SIU I <sup>2</sup> C_B PWM/Timer —	I/O	S	None, None	—	53	N5
PK[12]	—	—	Reserved	—	—	—	—	—	—	—	—
PK[13]	—	—	Reserved	—	—	—	—	—	—	—	—
PK[14]	—	—	Reserved	—	—	—	—	—	—	—	—
PK[15]	—	—	Reserved	—	—	—	—	—	—	—	—

<sup>1</sup> Alternate functions are chosen by setting the values of the PCR.PA bitfields inside the SIU module. PCR.PA = 00 -> Option 0; PCR.PA = 01 -> Option 1; PCR.PA = 10 -> Option 2; PCR.PA = 11-> Option 3. This is intended to select the output functions; to use one of the input functions, the PCR.IBE bit must be written to '1', regardless of the values selected in the PCR.PA bitfields. For this reason, the value corresponding to an input only function is reported as "—".

<sup>2</sup> A=A, S=Slow, M=Medium, F=Fast, SMD=Stepper Motor Driver

<sup>3</sup> Reset configuration is given as I/O direction and pull, e.g., "Input, pullup".

<sup>4</sup> Out of reset pins PH[0:3] are available as JTAG pins (TCK, TDI, TDO and TMS respectively). It is up to the user to configure pins PH[0:3] when needed.

## 2.4.7 Signal Details

**Table 7. Signal Details**

Signal	Peripheral	Description
ABS[0]	BAM	Alternate Boot Select. gives an option to boot by downloading code via CAN or LIN.
AN[0:15]	Analog-to-digital conversion (ADC)	Inputs used to bring into the device sensor-based signals for A/D conversion.
FABM		Force Alternate Boot mode. Forces the device to boot from the external bus (Can or LIN). If not asserted, the device boots up from the lowest flash sector containing a valid boot signature.
DCU_DE	Display Control Unit	Indicates that valid pixels are present when high; otherwise low to allow a sub frame display for pixels.
DCU_HSYNC,	Display Control Unit	Horizontal sync pulse for TFT-LCD display.
DCU_PCLK	Display Control Unit	Output pixel clock for TFT-LCD display
DCU_R[0:7], DCU_G[0:7] DCU_B[0:7]	Display Control Unit	Red, green and blue color 8 bit Pixel values for TFT-LCD displays.
DCU_TAG	Display Control Unit	High indicates certain pixels that can be called as tagged pixels, upon which internal CRC has been calculated based on pixel values and pixel position.
DCU_VSYNC	Display Control Unit	Vertical sync pulse for TFT-LCD display.
PCS_A[0:2], PCS_B[0:2], PCS_C[0:2]	DSPI	Peripheral chip selects when device is in Master mode; not used in slave modes.
SCK_A, SCK_B, SCK_C	DSPI	SPI clock signal - bi-directional.
SIN_A, SIN_B, SIN_C	DSPI	SPI data input signal.
SOUT_A, SOUT_B, SOUT_C	DSPI	SPI data output signal.
eMIOSA[0:23], eMIOSB[0:23]	eMIOS	Enhanced Modular Input Output System. 16+9 channel eMIOS for timed input or output functions.
CNRX_A, CNRX_B	FlexCAN	Receive (RX) pins for the CAN bus transceiver.
CNTX_A, CNTX_B	FlexCAN	Transmit (TX) pins for the CAN bus transceiver.
SCL_A, SCL_B, SCL_C, SCL_D	I <sup>2</sup> C	Bidirectional serial clock compatible with I <sup>2</sup> C specifications.
SDA_A, SDA_B, SDA_C, SDA_D	I <sup>2</sup> C	Bidirectional serial data compatible with I <sup>2</sup> C specifications.

Table 7. Signal Details (continued)

Signal	Peripheral	Description
TCK	JTAG	Debug port serial clock as per JTAG specifications.
TDI	JTAG	Debug port serial data input port as per JTAG standards specifications.
TDO	JTAG	Debug port serial data output port as per JTAG standards specifications.
TMS	JTAG	Debug port Test Mode Select signal for the JTAG TAP controller state machine and indicates various state transitions for the TAP controller in the device.
BP[0:3]	LCD	Back plane signals from the LCD controlling the back plane reference voltage for the LCD display.
FP[0:39]	LCD	Front plane signals for LCD segments.
$\overline{\text{EVTI}}$	Nexus	Nexus2+ event input trigger.
$\overline{\text{EVTO}}$	Nexus	Nexus2+ event output trigger.
MCKO	Nexus	Output clock for the development tool
MDO[0:3]	Nexus	Message output port pins that send information bits to the development tools for messages such as Branch Trace Message (BTM), Ownership Trace Message (OTM), Data Trace Message (DTM). Only available in reduced port mode.
$\overline{\text{MSEO}}$	Nexus	Output pin. Indicates the start or end of the variable length message on the MDO pins.
PDI[0:17]	Parallel Display Interface	Video/graphic data in various RGB modes input to the DCU.
PDI_DE	Parallel Display Interface	Input signal indicates the validity of pixel data on the Input PDI data bus. For valid Pixel Data this is high, otherwise low.
PDI_HSYNC	Parallel Display Interface	Input indicates the timing reference for the start of each frame line for the PDI Input data.
PDI_PCLK	Parallel Display Interface	Output pixel clock for PDI.
PDI_VSYNC	Parallel Display Interface	Input indicates the timing reference for the start of a frame for the PDI input data.
RXD_A	LINFlex-UART	SCI/LIN Receive data signal. This port is used to download the code for the BAM boot sequence
RXD_B	LINFlex-UART	SCI/LIN Receive data signal. Input pad for the LIN SCI module. Connects to the internal LIN second port.
TXD_A	LINFlex-UART	This port is used to download the code for the BAM boot sequence
TXD_B	LINFlex-UART	SCI/LIN Transmit data signal. Transmit (output) port for the second LIN module in the chip .
SOUND	Sound generation logic (SGL)	Sound signal to the speaker/buzzer.

Table 7. Signal Details (continued)

Signal	Peripheral	Description
SSD[0..5]_0 SSD[0..5]_1 SSD[0..5]_2 SSD[0..5]_3	SSD (Stepper Stall Detect) Interface	Bidirectional SSD inputs and control signals
M[0:5]C0M M[0:5]C0P M[0:5]C1M M[0:5]C1P	Stepper Motor Control (SMC) Interface	Controls stepper motors in Dual H bridge configuration.
CLKOUT	Clock generation module (CGM)	Output clock. It can be selected from several internal clocks of the device from the clock generation module.
MA[0:2]	ADC	These three control bits are output to enable the selection for an external Analog Mux for expansion channels.

### 3 Electrical Characteristics

This section contains electrical characteristics of the device as well as temperature and power considerations.

This product contains devices to protect the inputs against damage due to high static voltages. However, it is advisable to take precautions to avoid application of any voltage higher than the specified maximum rated voltages.

To enhance reliability, unused inputs can be driven to an appropriate logic voltage level ( $V_{DD}$  or  $V_{SS}$ ). This could be done by internal pull up and pull down, which is provided by the product for most general purpose pins.

The parameters listed in the following tables represent the characteristics of the device and its demands on the system.

In the tables where the device logic provides signals with their respective timing characteristics, the symbol “CC” for Controller Characteristics is included in the Symbol column.

In the tables where the external system must provide signals with their respective timing characteristics to the device, the symbol “SR” for System Requirement is included in the Symbol column.

#### 3.1 Absolute Maximum Ratings

Table 8. Absolute Maximum Ratings

Symbol		Parameter	Conditions	Value		Unit
				Min	Max	
$V_{DDA}$	SR	Voltage on VDDA pin (ADC reference) with respect to ground ( $V_{SSA}$ )		-0.3	+5.5	V
			Relative to $V_{DD}$	$V_{DD}-0.3$	$V_{DD}+0.3$	
$V_{SSA}$	SR	Voltage on VSSA (ADC reference) pin with respect to $V_{SS}$		$V_{SS}-0.1$	$V_{SS}+0.1$	V
$V_{DDPLL}$	CC	Voltage on VDDPLL (1.2 V PLL supply) pin with respect to ground ( $V_{SSPLL}$ )		1.08	1.32	V
			Relative to $V_{DD}$	$V_{DD}-0.3$	$V_{DD}+0.3$	
$V_{SSPLL}$	SR	Voltage on VSSMC (stepper motor supply ground) pin with respect to $V_{SS}$		$V_{SS}-0.1$	$V_{SS}+0.1$	V
$V_{DDR}$	SR	Voltage on VDDR pin (regulator supply) with respect to ground ( $V_{SSR}$ )		-0.3	+5.5	V
			Relative to $V_{DD}$	$V_{DD}-0.3$	$V_{DD}+0.3$	
$V_{SSR}$	SR	Voltage on VSSR (regulator ground) pin with respect to $V_{SS}$		$V_{SS}-0.1$	$V_{SS}+0.1$	V
$V_{DD12}$	CC	Voltage on VDD12 pin with respect to ground ( $V_{SS12}$ )		1.08	1.4	V
$V_{SS12}$	CC	Voltage on VSS12 pin with respect to $V_{SS}$		$V_{SS}-0.1$	$V_{SS}+0.1$	V
$V_{DDE\_A}^1$	SR	Voltage on VDDE_A (I/O supply) pin with respect to ground ( $V_{SSE\_A}$ )		-0.3	+5.5	V
$V_{DDE\_B}^1$	SR	Voltage on VDDE_B (I/O supply) pin with respect to ground ( $V_{SSE\_B}$ )		-0.3	+5.5	V
$V_{DDE\_C}^1$	SR	Voltage on VDDE_C (I/O supply) pin with respect to ground ( $V_{SSE\_C}$ )		-0.3	+5.5	V
$V_{DDE\_E}^1$	SR	Voltage on VDDE_E (I/O supply) pin with respect to ground ( $V_{SSE\_E}$ )		-0.3	+5.5	V

Table 8. Absolute Maximum Ratings (continued)

Symbol		Parameter	Conditions	Value		Unit
				Min	Max	
$V_{DDMA}^1$	SR	Voltage on VDDMA (stepper motor supply) pin with respect to ground ( $V_{SSMA}$ )		-0.3	+5.5	V
$V_{DDMB}^1$	SR	Voltage on VDDMB (stepper motor supply) pin with respect to ground ( $V_{SSMB}$ )		-0.3	+5.5	V
$V_{DDMC}^1$	SR	Voltage on VDDMC (stepper motor supply) pin with respect to ground ( $V_{SSMC}$ )		-0.3	+5.5	V
$V_{SS}^2$	SR	I/O supply ground		0	0	V
$V_{SSOSC}$	SR	Voltage on VSSOSC (oscillator ground) pin with respect to $V_{SS}$		$V_{SS}-0.1$	$V_{SS}+0.1$	V
$V_{LCD}$	SR	Voltage on VLCD (LCD supply) pin with respect to $V_{SS}$		0	$V_{DDE\_A} + 0.3$	V
$V_{IN}$	SR	Voltage on any GPIO pin with respect to ground ( $V_{SS}$ )		-0.3	+5.5	V
			Relative to $V_{DD}$	-0.3	$V_{DD}+0.3$	
$I_{INJPAD}$	SR	Injected input current on any pin during overload condition		-10	10	mA
$I_{INJSUM}$	SR	Absolute sum of all injected input currents during overload condition		-50	50	
$T_{STORAGE}$	SR	Storage temperature		-55	150	°C
$ESD_{HBM}$	SR	ESD Susceptibility (Human Body Model)			2000	V

<sup>1</sup> Throughout the remainder of this document  $V_{DD}$  refers collectively to I/O voltage supplies, i.e.,  $V_{DDE\_A}$ ,  $V_{DDE\_B}$ ,  $V_{DDE\_C}$ ,  $V_{DDE\_E}$ ,  $V_{DDMA}$ ,  $V_{DDMB}$  and  $V_{DDMC}$ , unless otherwise noted.

<sup>2</sup> Throughout the remainder of this document  $V_{SS}$  refers collectively to I/O voltage supply grounds, i.e.,  $V_{SSE\_A}$ ,  $V_{SSE\_B}$ ,  $V_{SSE\_C}$ ,  $V_{SSE\_E}$ ,  $V_{SSMA}$ ,  $V_{SSMB}$  and  $V_{SSMC}$ , unless otherwise noted.

### NOTE

Stresses exceeding the recommended absolute maximum ratings may cause permanent damage to the device. This is a stress rating only and functional operation of the device at these or any other conditions above those indicated in the operational sections of this specification are not implied. Exposure to absolute maximum rating conditions for extended periods may affect device reliability. During overload conditions ( $V_{IN} > V_{DD}$  or  $V_{IN} < V_{SS}$ ), the voltage on pins with respect to ground ( $V_{SS}$ ) must not exceed the recommended values.



### 3.1.1 Recommended Operating Conditions

Table 9. Recommended Operating Conditions (3.3 V)

Symbol	Parameter	Conditions	Value		Unit	
			Min	Max		
V <sub>DDA</sub> <sup>1</sup>	SR	Voltage on VDDA pin (ADC reference) with respect to ground (V <sub>SS</sub> )		+3.0	+3.6	V
			Relative to V <sub>DD</sub>	V <sub>DD</sub> -0.1	V <sub>DD</sub> +0.1	
V <sub>SSA</sub>	SR	Voltage on VSSA (ADC reference) pin with respect to V <sub>SS</sub>		V <sub>SS</sub> -0.1	V <sub>SS</sub> +0.1	V
V <sub>DDPLL</sub>	CC	Voltage on VDDPLL (1.2 V PLL supply) pin with respect to ground (V <sub>SSPLL</sub> )		1.08	1.32	V
V <sub>SSPLL</sub>	SR	Voltage on VSSMC (stepper motor supply ground) pin with respect to V <sub>SS</sub>		V <sub>SS</sub> -0.1	V <sub>SS</sub> +0.1	V
V <sub>DDR</sub> <sup>2</sup>	SR	Voltage on VDDR pin (regulator supply) with respect to ground (V <sub>SSR</sub> )		+3.0	+3.6	V
			Relative to V <sub>DD</sub>	V <sub>DD</sub> -0.1	V <sub>DD</sub> +0.1	
V <sub>SSR</sub>	SR	Voltage on VSSR (regulator ground) pin with respect to V <sub>SS</sub>		V <sub>SS</sub> -0.1	V <sub>SS</sub> +0.1	V
V <sub>DD12</sub> <sup>3,4</sup>	CC	Voltage on VDD12 pin with respect to ground (V <sub>SS12</sub> )		1.08	1.4	V
V <sub>SS12</sub>	CC	Voltage on VSS12 pin with respect to V <sub>SS</sub>		V <sub>SS</sub> -0.1	V <sub>SS</sub> +0.1	V
V <sub>DD</sub> <sup>5,6,7</sup>	SR	Voltage on VDD pins (VDDE_A, VDDE_B, VDDE_C, VDDE_E, VDDMA, VDDMB, VDDMC) with respect to ground (V <sub>SS</sub> )		+3.0	+3.6	V
V <sub>SS</sub> <sup>8</sup>	SR	I/O supply ground		0	0	V
V <sub>DDDE_A</sub>	SR	Voltage on VDDE_A (I/O supply) pin with respect to ground (V <sub>SSE_A</sub> )		+3.0	+3.6	V
V <sub>DDDE_B</sub>	SR	Voltage on VDDE_B (I/O supply) pin with respect to ground (V <sub>SSE_B</sub> )		+3.0	+3.6	V
V <sub>DDDE_C</sub> <sup>9</sup>	SR	Voltage on VDDE_C (I/O supply) pin with respect to ground (V <sub>SSE_C</sub> )		+3.0	+3.6	V
V <sub>DDDE_E</sub>	SR	Voltage on VDDE_E (I/O supply) pin with respect to ground (V <sub>SSE_E</sub> )		+3.0	+3.6	V
V <sub>DDMA</sub>	SR	Voltage on VDDMA (stepper motor supply) pin with respect to ground (V <sub>SSMA</sub> )		+3.0	+3.6	V
V <sub>DDMB</sub>	SR	Voltage on VDDMB (stepper motor supply) pin with respect to ground (V <sub>SSMB</sub> )		+3.0	+3.6	V
V <sub>DDMC</sub>	SR	Voltage on VDDMC (stepper motor supply) pin with respect to ground (V <sub>SSMC</sub> )		+3.0	+3.6	V
V <sub>SSOSC</sub>	SR	Voltage on VSSOSC (oscillator ground) pin with respect to V <sub>SS</sub>		0	0	V

**Table 9. Recommended Operating Conditions (3.3 V) (continued)**

Symbol		Parameter	Conditions	Value		Unit
				Min	Max	
V <sub>LCD</sub>	SR	Voltage on VLCD (LCD supply) pin with respect to V <sub>SS</sub>		0	V <sub>DDE_A</sub> +0.3	V
TV <sub>DD</sub>	SR	V <sub>DD</sub> slope to ensure correct power up <sup>10</sup>			0.25	V/μs
T <sub>A</sub>	SR	Ambient temperature under bias		-40	+105	°C
T <sub>J</sub>	SR	Junction temperature under bias		-40	+150	

<sup>1</sup> 100 nF capacitance needs to be provided between V<sub>DDA</sub>/V<sub>SSA</sub> pair.

<sup>2</sup> 200 μF capacitance must be connected between V<sub>DDR</sub> and V<sub>SS12</sub>.

<sup>3</sup> V<sub>DD12</sub> cannot be used to drive any external component.

<sup>4</sup> Each V<sub>DD12</sub>/V<sub>SS12</sub> supply pair should have a 10 μF capacitor. Absolute combined maximum capacitance is 40 μF.

<sup>5</sup> V<sub>DD</sub> refers collectively to I/O voltage supplies, i.e., V<sub>DDE\_A</sub>, V<sub>DDE\_B</sub>, V<sub>DDE\_C</sub>, V<sub>DDE\_E</sub>, V<sub>DDMA</sub>, V<sub>DDMB</sub> and V<sub>DDMC</sub>.

<sup>6</sup> 100 nF capacitance needs to be provided between each V<sub>DD</sub>/V<sub>SS</sub> pair

<sup>7</sup> Full electrical specification cannot be guaranteed when voltage drops below 3.0V. In particular, ADC electrical characteristics and I/O's DC electrical specification may not be guaranteed.

When voltage drops below V<sub>LVDHVL</sub> device is reset.

<sup>8</sup> V<sub>SS</sub> refers collectively to I/O voltage supply grounds, i.e., V<sub>SSE\_A</sub>, V<sub>SSE\_B</sub>, V<sub>SSE\_C</sub>, V<sub>SSE\_E</sub>, V<sub>SSMA</sub>, V<sub>SSMB</sub> and V<sub>SSMC</sub> unless otherwise noted.

<sup>9</sup> V<sub>DDE\_C</sub> should not be less than V<sub>DDA</sub>.

<sup>10</sup> Guaranteed by device validation

**Table 10. Recommended Operating Conditions (5.0 V)**

Symbol		Parameter	Conditions	Value		Unit
				Min	Max	
V <sub>DDA</sub> <sup>1</sup>	SR	Voltage on VDDA pin (ADC reference) with respect to ground (V <sub>SS</sub> )		+4.5	+5.5	V
			Voltage drop <sup>2</sup>	+3.0	+5.5	
			Relative to V <sub>DD</sub>	V <sub>DD</sub> -0.1	V <sub>DD</sub> +0.1	
V <sub>SSA</sub>	SR	Voltage on VSSA (ADC reference) pin with respect to V <sub>SS</sub>		V <sub>SS</sub> -0.1	V <sub>SS</sub> +0.1	V
V <sub>DDPLL</sub>	CC	Voltage on VDDPLL (1.2 V PLL supply) pin with respect to ground (V <sub>SSPLL</sub> )		1.08	1.32	V
V <sub>SSPLL</sub>	SR	Voltage on VSSMC (stepper motor supply ground) pin with respect to V <sub>SS</sub>		V <sub>SS</sub> -0.1	V <sub>SS</sub> +0.1	V
V <sub>DDR</sub> <sup>3</sup>	SR	Voltage on VDDR pin (regulator supply) with respect to ground (V <sub>SSR</sub> )		+4.5	+5.5	V
			Voltage drop <sup>2</sup>	+3.0	+5.5	
			Relative to V <sub>DD</sub>	V <sub>DD</sub> -0.1	V <sub>DD</sub> +0.1	
V <sub>SSR</sub>	SR	Voltage on VSSR (regulator ground) pin with respect to V <sub>SS</sub>		V <sub>SS</sub> -0.1	V <sub>SS</sub> +0.1	V
V <sub>DD12</sub> <sup>4,5</sup>	CC	Voltage on VDD12 pin with respect to ground (V <sub>SS12</sub> )		1.08	1.4	V

Table 10. Recommended Operating Conditions (5.0 V) (continued)

Symbol	Parameter	Conditions	Value		Unit
			Min	Max	
V <sub>SS12</sub>	CC	Voltage on VSS12 pin with respect to V <sub>SS</sub>	V <sub>SS</sub> -0.1	V <sub>SS</sub> +0.1	V
V <sub>DD</sub> <sup>6,7</sup>	SR	Voltage on VDD pins (VDDE_A, VDDE_B, VDDE_C, VDDE_E, VDDMA, VDDMB, VDDMC) with respect to ground (V <sub>SS</sub> )	+4.5	+5.5	V
V <sub>SS</sub> <sup>8</sup>	SR	I/O supply ground	0	0	V
V <sub>DDE_A</sub>	SR	Voltage on VDDE_A (I/O supply) pin with respect to ground (V <sub>SSE_A</sub> )	+4.5	+5.5	V
V <sub>DDE_B</sub>	SR	Voltage on VDDE_B (I/O supply) pin with respect to ground (V <sub>SSE_B</sub> )	+4.5	+5.5	V
V <sub>DDE_C</sub> <sup>9</sup>	SR	Voltage on VDDE_C (I/O supply) pin with respect to ground (V <sub>SSE_C</sub> )	+4.5	+5.5	V
V <sub>DDE_E</sub>	SR	Voltage on VDDE_E (I/O supply) pin with respect to ground (V <sub>SSE_E</sub> )	+4.5	+5.5	V
V <sub>DDMA</sub>	SR	Voltage on VDDMA (stepper motor supply) pin with respect to ground (V <sub>SSMA</sub> )	+4.5	+5.5	V
V <sub>DDMB</sub>	SR	Voltage on VDDMB (stepper motor supply) pin with respect to ground (V <sub>SSMB</sub> )	+4.5	+5.5	V
V <sub>DDMC</sub>	SR	Voltage on VDDMC (stepper motor supply) pin with respect to ground (V <sub>SSMC</sub> )	+4.5	+5.5	V
V <sub>SSOSC</sub>	SR	Voltage on VSSOSC (oscillator ground) pin with respect to V <sub>SS</sub>	0	0	V
V <sub>LCD</sub>	SR	Voltage on VLCD (LCD supply) pin with respect to V <sub>SS</sub>	0	V <sub>DDE_A</sub> +0.3	V
T <sub>VDD</sub>	SR	V <sub>DD</sub> slope to ensure correct power up <sup>10</sup>		0.25	V/μs
T <sub>A</sub>	SR	Ambient temperature under bias	-40	+105	°C
			-40	+105	
T <sub>J</sub>	SR	Junction temperature under bias	-40	+150	

<sup>1</sup> 100 nF capacitance needs to be provided between V<sub>DDA</sub>/V<sub>SSA</sub> pair.

<sup>2</sup> Full functionality cannot be guaranteed when voltage drops below 4.5 V. In particular, I/O DC and ADC electrical characteristics may not be guaranteed below 4.5 V during the voltage drop sequence.

<sup>3</sup> 200 μF capacitance must be connected between V<sub>DDR</sub> and V<sub>SS12</sub>.

<sup>4</sup> V<sub>DD12</sub> cannot be used to drive any external component.

<sup>5</sup> Each V<sub>DD12</sub>/V<sub>SS12</sub> supply pair should have a 10 μF capacitor. Absolute combined maximum capacitance is 40 μF.

<sup>6</sup> V<sub>DD</sub> refers collectively to I/O voltage supplies, i.e., V<sub>DDE\_A</sub>, V<sub>DDE\_B</sub>, V<sub>DDE\_C</sub>, V<sub>DDE\_E</sub>, V<sub>DDMA</sub>, V<sub>DDMB</sub> and V<sub>DDMC</sub>.

<sup>7</sup> 100 nF capacitance needs to be provided between each V<sub>DD</sub>/V<sub>SS</sub> pair

<sup>8</sup> V<sub>SS</sub> refers collectively to I/O voltage supply grounds, i.e., V<sub>SSE\_A</sub>, V<sub>SSE\_B</sub>, V<sub>SSE\_C</sub>, V<sub>SSE\_E</sub>, V<sub>SSMA</sub>, V<sub>SSMB</sub> and V<sub>SSMC</sub>) unless otherwise noted.

<sup>9</sup> V<sub>DDE\_C</sub> should not be less than V<sub>DDA</sub>.

<sup>10</sup> Guaranteed by device validation

## 3.2 Thermal Characteristics

**Table 11. Thermal Characteristics for 144-pin LQFP<sup>1</sup>**

Symbol		Parameter	Conditions	Value	Unit
$R_{\theta JA}$	CC	Junction to Ambient Natural Convection <sup>2</sup>	Single layer board - 1s	50	°C/W
$R_{\theta JA}$	CC	Junction to Ambient Natural Convection <sup>2</sup>	Four layer board - 2s2p	41	°C/W
$R_{\theta JMA}$	CC	Junction to Ambient <sup>2</sup>	@200 ft./min., single layer board - 1s	41	°C/W
$R_{\theta JMA}$	CC	Junction to Ambient <sup>2</sup>	@200 ft./min., four layer board- 2s2p	35	°C/W
$R_{\theta JB}$	CC	Junction to Board <sup>3</sup>		29	°C/W
$R_{\theta JCTop}$	CC	Junction to Case <sup>4</sup>		10	°C/W
$\Psi_{JT}$	CC	Junction to Package Top Natural Convection <sup>5</sup>		2	°C/W

<sup>1</sup> Thermal characteristics are targets based on simulation that are subject to change per device characterization.

<sup>2</sup> Junction-to-Ambient Thermal Resistance determined per JEDEC JESD51-3 and JESD51-6. Thermal test board meets JEDEC specification for this package.

<sup>3</sup> Junction-to-Board thermal resistance determined per JEDEC JESD51-8. Thermal test board meets JEDEC specification for the specified package.

<sup>4</sup> Junction-to-Case at the top of the package determined using MIL-STD 883 Method 1012.1. The cold plate temperature is used for the case temperature. Reported value includes the thermal resistance of the interface layer.

<sup>5</sup> Thermal characterization parameter indicating the temperature difference between the package top and the junction temperature per JEDEC JESD51-2. When Greek letters are not available, the thermal characterization parameter is written as Psi-JT.

**Table 12. Thermal Characteristics for 176-pin LQFP<sup>1</sup>**

Symbol		Parameter	Conditions	Value	Unit
$R_{\theta JA}$	CC	Junction to Ambient Natural Convection <sup>2</sup>	Single layer board - 1s	43	°C/W
$R_{\theta JA}$	CC	Junction to Ambient Natural Convection <sup>2</sup>	Four layer board - 2s2p	35	°C/W
$R_{\theta JMA}$	CC	Junction to Ambient <sup>2</sup>	@200 ft./min., single layer board - 1s	35	°C/W
$R_{\theta JMA}$	CC	Junction to Ambient <sup>2</sup>	@200 ft./min., Four layer board - 2s2p	30	°C/W
$R_{\theta JB}$	CC	Junction to Board <sup>3</sup>		24	°C/W
$R_{\theta JCTop}$	CC	Junction to Case (Top) <sup>4</sup>		9	°C/W
$\Psi_{JT}$	CC	Junction to Package Top Natural Convection <sup>5</sup>		2	°C/W

<sup>1</sup> Thermal characteristics are targets based on simulation that are subject to change per device characterization.

<sup>2</sup> Junction-to-Ambient Thermal Resistance determined per JEDEC JESD51-3 and JESD51-6. Thermal test board meets JEDEC specification for this package.

<sup>3</sup> Junction-to-Board thermal resistance determined per JEDEC JESD51-8. Thermal test board meets JEDEC specification for the specified package.

<sup>4</sup> Junction-to-Case at the top of the package determined using MIL-STD 883 Method 1012.1. The cold plate temperature is used for the case temperature. Reported value includes the thermal resistance of the interface layer.

<sup>5</sup> Thermal characterization parameter indicating the temperature difference between the package top and the junction temperature per JEDEC JESD51-2. When Greek letters are not available, the thermal characterization parameter is written as Psi-JT.

### 3.2.1 General Notes for Specifications at Maximum Junction Temperature

An estimate of the chip junction temperature,  $T_J$ , can be obtained from the equation:

$$T_J = T_A + (R_{\theta JA} * P_D) \quad \text{Eqn. 1}$$

where:

$T_A$  = ambient temperature for the package ( $^{\circ}\text{C}$ )

$R_{\theta JA}$  = junction to ambient thermal resistance ( $^{\circ}\text{C}/\text{W}$ )

$P_D$  = power dissipation in the package (W)

The thermal resistance values used are based on the JEDEC JESD51 series of standards to provide consistent values for estimations and comparisons. The difference between the values determined for the single-layer (1s) board compared to a four-layer board that has two signal layers, a power and a ground plane (2s2p), demonstrate that the effective thermal resistance is not a constant. The thermal resistance depends on the:

- Construction of the application board (number of planes)
- Effective size of the board which cools the component
- Quality of the thermal and electrical connections to the planes
- Power dissipated by adjacent components

Connect all the ground and power balls to the respective planes with one via per ball. Using fewer vias to connect the package to the planes reduces the thermal performance. Thinner planes also reduce the thermal performance. When the clearance between the vias leave the planes virtually disconnected, the thermal performance is also greatly reduced.

As a general rule, the value obtained on a single-layer board is within the normal range for the tightly packed printed circuit board. The value obtained on a board with the internal planes is usually within the normal range if the application board has:

- One oz. (35 micron nominal thickness) internal planes
- Components are well separated
- Overall power dissipation on the board is less than 0.02 W/cm<sup>2</sup>

The thermal performance of any component depends on the power dissipation of the surrounding components. In addition, the ambient temperature varies widely within the application. For many natural convection and especially closed box applications, the board temperature at the perimeter (edge) of the package is approximately the same as the local air temperature near the device. Specifying the local ambient conditions explicitly as the board temperature provides a more precise description of the local ambient conditions that determine the temperature of the device.

At a known board temperature, the junction temperature is estimated using the following equation:

$$T_J = T_B + (R_{\theta JB} * P_D) \quad \text{Eqn. 2}$$

where:

$T_B$  = board temperature for the package perimeter ( $^{\circ}\text{C}$ )

$R_{\theta JB}$  = junction-to-board thermal resistance ( $^{\circ}\text{C}/\text{W}$ ) per JESD51-8S

$P_D$  = power dissipation in the package (W)

When the heat loss from the package case to the air does not factor into the calculation, an acceptable value for the junction temperature is predictable. Ensure the application board is similar to the thermal test condition, with the component soldered to a board with internal planes.

The thermal resistance is expressed as the sum of a junction-to-case thermal resistance plus a case-to-ambient thermal resistance:

$$R_{\theta JA} = R_{\theta JC} + R_{\theta CA} \quad \text{Eqn. 3}$$

## Electrical Characteristics

where:

$R_{\theta JA}$  = junction to ambient thermal resistance ( $^{\circ}\text{C}/\text{W}$ )

$R_{\theta JC}$  = junction to case thermal resistance ( $^{\circ}\text{C}/\text{W}$ )

$R_{\theta CA}$  = case to ambient thermal resistance ( $^{\circ}\text{C}/\text{W}$ )

$R_{\theta JC}$  is device related and is not affected by other factors. The thermal environment can be controlled to change the case-to-ambient thermal resistance,  $R_{\theta CA}$ . For example, change the air flow around the device, add a heat sink, change the mounting arrangement on the printed circuit board, or change the thermal dissipation on the printed circuit board surrounding the device. This description is most useful for packages with heat sinks where 90% of the heat flow is through the case to heat sink to ambient. For most packages, a better model is required.

A more accurate two-resistor thermal model can be constructed from the junction-to-board thermal resistance and the junction-to-case thermal resistance. The junction-to-case thermal resistance describes when using a heat sink or where a substantial amount of heat is dissipated from the top of the package. The junction-to-board thermal resistance describes the thermal performance when most of the heat is conducted to the printed circuit board. This model can be used to generate simple estimations and for computational fluid dynamics (CFD) thermal models.

To determine the junction temperature of the device in the application on a prototype board, use the thermal characterization parameter ( $\Psi_{JT}$ ) to determine the junction temperature by measuring the temperature at the top center of the package case using the following equation:

$$T_J = T_T + (\Psi_{JT} \times P_D) \quad \text{Eqn. 4}$$

where:

$T_T$  = thermocouple temperature on top of the package ( $^{\circ}\text{C}$ )

$\Psi_{JT}$  = thermal characterization parameter ( $^{\circ}\text{C}/\text{W}$ )

$P_D$  = power dissipation in the package (W)

The thermal characterization parameter is measured in compliance with the JESD51-2 specification using a 40-gauge type T thermocouple epoxied to the top center of the package case. Position the thermocouple so that the thermocouple junction rests on the package. Place a small amount of epoxy on the thermocouple junction and approximately 1 mm of wire extending from the junction. Place the thermocouple wire flat against the package case to avoid measurement errors caused by the cooling effects of the thermocouple wire.

References:

Semiconductor Equipment and Materials International  
Middlefield Rd.  
CA 94043

805 East  
Mountain View,  
(415) 964-5111

MIL-SPEC and EIA/JESD (JEDEC) specifications are available from Global Engineering Documents at 800-854-7179 or 303-397-7956.

JEDEC specifications are available on the WEB at <http://www.jedec.org>.

### 3.3 EMI (Electromagnetic Interference) Characteristics

Table 13. EMI Testing Specifications<sup>1</sup>

Symbol		Parameter	Value			Unit
			min	typ	max	
—	SR	Scan Range	TBD	TBD	TBD	MHz
—	SR	Operating Frequency	TBD	TBD	TBD	MHz
—	SR	VDD12, VDDPLL Operating Voltages	TBD	TBD	TBD	V
—	SR	VDD, VDDA Operating Voltages	TBD	TBD	TBD	V
—	SR	Maximum Amplitude	TBD	TBD	TBD	dBuV
—	SR	Operating Temperature	TBD	TBD	TBD	°C

<sup>1</sup> EMI testing and I/O port waveforms per SAE J1752/3 issued 1995-03.

### 3.4 Power Management

#### 3.4.1 Voltage Regulator Electrical Characteristics

The internal voltage regulator requires an external NPN (BCP56 or BCP68) ballast to be connected as shown in [Figure 5](#) as well as an external capacitance ( $C_{REG}$ ) to be connected to the device in order to provide a stable low voltage digital supply to the device. Capacitances should be placed on the board as near as possible to the associated pins. Care should also be taken to limit the serial inductance of the board to less than 15 nH.

For the MPC5606S microcontroller, 10  $\mu$ F should be placed between each of the three  $V_{DD12}/V_{SS12}$  supply pairs and also between the  $V_{DDPLL}/V_{SSPLL}$  pair. Additionally, 200  $\mu$ F should be placed between the  $V_{DDR}$  pin and the adjacent  $V_{SS}$  pin.

$V_{DDR} = 3.0\text{ V to }3.6\text{ V} / 4.5\text{ V to }5.5\text{ V}$ ,  $T_A = -40\text{ to }105\text{ }^\circ\text{C}$ , unless otherwise specified.

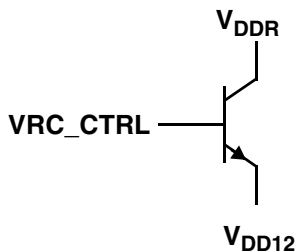

Figure 5. External NPN Ballast Connections

**Table 14. Voltage Regulator Electrical Characteristics<sup>1</sup>**

No.	Symbol	Parameter	Conditions	Min	Max	Unit	
1	V <sub>DDR</sub>	SR Power supply		3.0	5.5	V	
2	T <sub>J</sub>	SR Junction temperature		-40	150	°C	
3	I <sub>REG</sub>	CC Current consumption	Reference included, @ 55 °C No load @ Full load	—	2 11	mA	
4	I <sub>L</sub>	CC Output current capacity	DC load current	—	200	mA	
5	V <sub>DD12</sub>	CC Output voltage (value @ I <sub>L</sub> = 0 @ 27°C)	Pre-trimming sigma < 7 mV	—	1.330	V	
			Post-trimming	1.270	1.280		
		CC Output voltage (value @ I <sub>L</sub> = I <sub>max</sub> )	Post-trimming	1.145	—		
6		SR External decoupling/stability capacitor	4 capacitances of 10 μF each	10 * 4		μF	
			ESR of external cap	0.05	0.2		ohm
			1 bond wire R + 1 pad R	0.2	1		ohm
7	L <sub>BOND</sub>	CC Bonding Inductance for Bipolar Base Control pad		0	15	nH	
8		CC Power supply rejection	@ DC @ no load	Cload = 10 μF * 4	—	-30	dB
			@ 200 kHz @ no load		-100		
			@ DC @ 400 mA		-30		
			@ 200 kHz @ 400 mA		-30		
9		CC Load current transient	Cload = 10 μF * 4	—	10% to 90% of I <sub>L</sub> (max) in 100 ns		
10	t <sub>SU</sub>	CC Start-up time after input supply stabilizes <sup>2</sup>	Cload = 10 μF * 4	—	500	μs	

<sup>1</sup> All values in this table are PRELIMINARY.

<sup>2</sup> Time after the input supply to the voltage regulator has ramped up (V<sub>DDR</sub>) and the voltage regulator has asserted the Power OK signal.

### 3.4.2 Voltage monitor electrical characteristics

The device implements a Power On Reset module to ensure correct power-up initialization, as well as four low voltage detectors to monitor the V<sub>DD</sub> and the V<sub>DD12</sub> voltage while device is supplied:

- POR monitors V<sub>DD</sub> during the power-up phase to ensure device is maintained in a safe reset state
- LVDHV3 monitors V<sub>DD</sub> to ensure device reset below minimum functional supply
- LVDHV5 monitors V<sub>DD</sub> when application uses device in the 5.0V ± 10% range
- LVDLVCOR monitors power domain No. 1
- LVDLVBKP monitors power domain No. 0



Table 15. Low voltage monitor electrical characteristics

Symbol		Parameter	Conditions <sup>1</sup>	Value <sup>2</sup>			Unit
				Min	Typ	Max	
V <sub>PORH</sub>	CC	Power-on reset threshold	T <sub>A</sub> = 25°C, after trimming	1.5	—	2.7	V
V <sub>LVDHV3H</sub>	CC	LVDHV3 low voltage detector high threshold		—	—	2.8	
V <sub>LVDHV3L</sub>	CC	LVDHV3 low voltage detector low threshold		2.7	—	—	
V <sub>LVDHV5H</sub>	CC	LVDHV5 low voltage detector high threshold		—	—	4.37	
V <sub>LVDHV5L</sub>	CC	LVDHV5 low voltage detector low threshold		4.2	—	—	
V <sub>LVDLVCORH</sub>	CC	LVDLVCOR low voltage detector high threshold		—	—	1.185	
V <sub>LVDLVCORL</sub>	CC	LVDLVCOR low voltage detector low threshold		1.095	—	—	

<sup>1</sup> V<sub>DD</sub> = 3.3V ± 10% / 5.0V ± 10%, T<sub>A</sub> = -40 / +105°C, unless otherwise specified

<sup>2</sup> All values need to be confirmed during device validation.

### 3.4.3 Low voltage domain power consumption

Table 16 provides DC electrical characteristics for significant application modes. These values are indicative values; actual consumption depends on the application.

Table 16. DC electrical characteristics

Symbol		Parameter	Conditions <sup>1</sup>	Value <sup>2</sup>			Unit
				Min	Typ	Max	
I <sub>DDMAX</sub>	SR	Maximum current		—	—	135	mA
I <sub>DDRUN</sub> <sup>3</sup>	CC	RUN mode current		—	130	—	mA
I <sub>DDWAIT</sub>	CC	WAIT mode current		—	30	—	mA
I <sub>DDHALT</sub>	CC	HALT mode current		4.5	—	12	mA
I <sub>DDSTOP</sub>	CC	STOP mode current	IRC 16 MHz oscillator off	—	1.5	—	mA
I <sub>DDSTOP</sub>	CC	STOP mode current	HPVREG off	—	800	—	μA
I <sub>DDSTOP</sub>	CC	STOP mode current	IRC 16 MHz oscillator on	—	4	—	mA
I <sub>DDSTDBY</sub>	CC	STANDBY mode current	IRC 16 MHz oscillator off	—	29	—	μA
I <sub>DDSTDBY</sub>	CC	STANDBY mode current	IRC 16 MHz oscillator on	—	300	—	μA

<sup>1</sup> V<sub>DD</sub> = 3.3V ± 10% / 5.0V ± 10%, T<sub>A</sub> = -40 / +125 °C

<sup>2</sup> All values need to be confirmed during device validation.

<sup>3</sup> Value is for maximum peripherals turned on. May vary significantly based on different configurations, active peripherals, operating frequency, etc.

### 3.5 DC Electrical Specifications

### 3.6 I/O Pad Electrical Characteristics

#### 3.6.1 I/O Pad Types

The device provides four main I/O pad types depending of the associated alternate functions:

- *Slow pads* are the most common pads, providing a good compromise between transition time and low electromagnetic emission.
- *Medium pads* provide fast enough transition for the serial communication channels with controlled current to reduce electromagnetic emission.
- *Fast pads* provide maximum speed. There are used for improved NEXUS debugging capability.

Medium and Fast pads can use slow configuration to reduce electromagnetic emission, at the cost of reducing AC performance.

#### 3.6.2 I/O Input DC Characteristics

Table 17 provides input DC electrical characteristics as described in Figure 6.

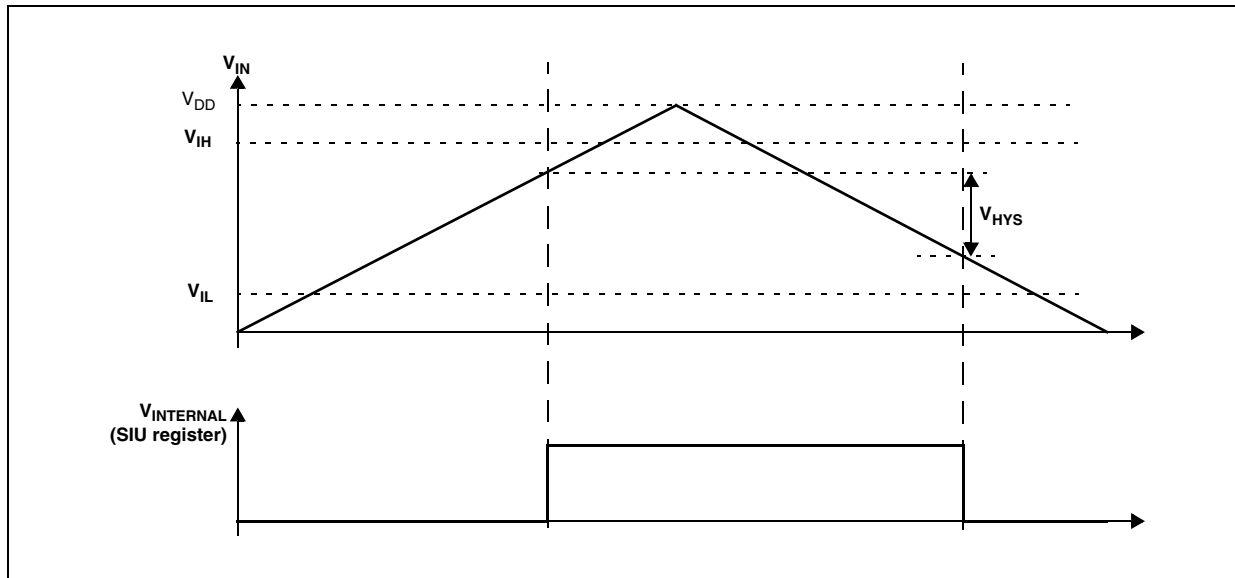

Figure 6. I/O Input DC Electrical Characteristics Definition

Table 17. I/O Input DC Electrical Characteristics

Symbol		Parameter	Conditions <sup>1</sup>	Value <sup>2</sup>			Unit
				Min	Typ	Max	
V <sub>IH</sub>	SR	Input high level CMOS Schmitt Trigger		0.65V <sub>DD</sub>		V <sub>DD</sub> +0.4	V
V <sub>IL</sub>	SR	Input low level CMOS Schmitt Trigger		-0.4		0.35V <sub>DD</sub>	
V <sub>HYS</sub>	CC <sup>3</sup>	Input hysteresis CMOS Schmitt Trigger		0.1V <sub>DD</sub>			

- <sup>1</sup>  $V_{DD} = 3.3\text{ V} \pm 10\% / 5.0\text{ V} \pm 10\%$ ,  $T_A = -40$  to  $+105\text{ }^\circ\text{C}$ .  
<sup>2</sup> All values need to be confirmed during device validation.  
<sup>3</sup> Parameter value guaranteed by design.

### 3.6.3 I/O Output DC Characteristics

The following tables provide DC characteristics for bidirectional pads:

- [Table 18](#) provides weak pull figures. Both pull-up and pull-down resistances are supported.
- [Table 19](#) provides output driver characteristics for I/O pads when in SLOW configuration.
- [Table 20](#) provides output driver characteristics for I/O pads when in MEDIUM configuration.
- [Table 21](#) provides output driver characteristics for I/O pads when in FAST configuration.

**Table 18. I/O Pull-up/Pull-down DC Electrical Characteristics**

Symbol	Parameter	Conditions <sup>1</sup>	Value <sup>2</sup>			Unit
			Min	Typ	Max	
$I_{WPU}$	CC	Weak pull-up current absolute value	10		—	$\mu\text{A}$
$I_{WPD}$	CC	Weak pull-down current absolute value	10		—	

<sup>1</sup>  $V_{DD} = 3.3\text{V} \pm 10\% / 5.0\text{V} \pm 10\%$ ,  $T_A = -40$  to  $+105^\circ\text{C}$ , unless otherwise specified.

<sup>2</sup> All values need to be confirmed during device validation.

**Table 19. SLOW Configuration Output Buffer Electrical Characteristics**

Symbol	Parameter	Conditions <sup>1</sup>	Value <sup>2</sup>			Unit	
			Min	Typ	Max		
$V_{OH}$	CC	Output high level SLOW configuration	Push Pull, $I_{OH} = -2\text{mA}$ , $V_{DD} = 5.0\text{V} \pm 10\%$ , $ipp\_hve = 0$ (recommended)	$0.8V_{DD}$			V
			Push Pull, $I_{OH} = -2\text{mA}$ , $V_{DD} = 5.0\text{V} \pm 10\%$ , $ipp\_hve = 1^3$	$0.8V_{DD}$			
			Push Pull, $I_{OH} = -1\text{mA}$ , $V_{DD} = 3.3\text{V} \pm 10\%$ , $ipp\_hve = 1$ (recommended)	$V_{DD} \cdot 0.8$			
$V_{OL}$	CC	Output low level SLOW configuration	Push Pull, $I_{OL} = 2\text{mA}$ , $V_{DD} = 5.0\text{V} \pm 10\%$ , $ipp\_hve = 0$ (recommended)			$0.1V_{DD}$	V
			Push Pull, $I_{OL} = 2\text{mA}$ , $V_{DD} = 5.0\text{V} \pm 10\%$ , $ipp\_hve = 1^3$			$0.1V_{DD}$	
			Push Pull, $I_{OL} = 1\text{mA}$ , $V_{DD} = 3.3\text{V} \pm 10\%$ , $ipp\_hve = 1$ (recommended)			0.5	

**Table 19. SLOW Configuration Output Buffer Electrical Characteristics (continued)**

Symbol		Parameter	Conditions <sup>1</sup>	Value <sup>2</sup>			Unit
				Min	Typ	Max	
T <sub>tr</sub>	CC <sup>4</sup>	Output transition time output pin <sup>5</sup> SLOW configuration	C <sub>L</sub> = 25pF, V <sub>DD</sub> = 5.0V ± 10%, ipp_hve = 0			50 <sup>6</sup>	ns
			C <sub>L</sub> = 50pF, V <sub>DD</sub> = 5.0V ± 10%, ipp_hve = 0			100 <sup>6</sup>	
			C <sub>L</sub> = 100pF, V <sub>DD</sub> = 5.0V ± 10%, ipp_hve = 0			125 <sup>4</sup>	
			C <sub>L</sub> = 25pF, V <sub>DD</sub> = 3.3V ± 10%, ipp_hve = 1			40 <sup>6</sup>	
			C <sub>L</sub> = 50pF, V <sub>DD</sub> = 3.3V ± 10%, ipp_hve = 1			50 <sup>6</sup>	
			C <sub>L</sub> = 100pF, V <sub>DD</sub> = 3.3V ± 10%, ipp_hve = 1			75 <sup>4</sup>	
ΔI <sub>tr50</sub>	CC <sup>4</sup>	Current slew at C <sub>L</sub> = 50pF SLOW configuration	recommended configuration at V <sub>DD</sub> = 5.0V ± 10%, ipp_hve = 0, V <sub>DD</sub> = 3.3V ± 10%, ipp_hve = 1			2	mA/ns
			V <sub>DD</sub> = 5.0V ± 10%, ipp_hve = 1			7	

<sup>1</sup> V<sub>DD</sub> = 3.3V ± 10% / 5.0V ± 10%, T<sub>A</sub> = -40 to +105°C, unless otherwise specified

<sup>2</sup> All values need to be confirmed during device validation.

<sup>3</sup> This is a transient configuration during power-up. All pads but RESET and NEXUS output (MDOx, EVTO, MCK) are configured in input or in high impedance state.

<sup>4</sup> Data based on characterization results, not tested in production

<sup>5</sup> C<sub>L</sub> calculation should include device and package capacitances (C<sub>PKG</sub> < 5pF).

<sup>6</sup> Data based on simulation results, not tested in production

**Table 20. MEDIUM Configuration Output Buffer Electrical Characteristics**

Symbol		Parameter	Conditions <sup>1</sup>	Value <sup>2</sup>			Unit
				Min	Typ	Max	
V <sub>OH</sub>	CC	Output high level MEDIUM configuration	Push Pull, I <sub>OH</sub> = -2mA, V <sub>DD</sub> = 5.0V ± 10%, ipp_hve = 0 (recommended)	0.8V <sub>DD</sub>			V
			Push Pull, I <sub>OH</sub> = -1mA, V <sub>DD</sub> = 5.0V ± 10%, ipp_hve = 1 <sup>3</sup>	0.8V <sub>DD</sub>			
			Push Pull, I <sub>OH</sub> = -1mA, V <sub>DD</sub> = 3.3V ± 10%, ipp_hve = 1 (recommended)	V <sub>DD</sub> -0.8			

Table 20. MEDIUM Configuration Output Buffer Electrical Characteristics (continued)

Symbol		Parameter	Conditions <sup>1</sup>	Value <sup>2</sup>			Unit
				Min	Typ	Max	
V <sub>OL</sub>	CC	Output low level MEDIUM configuration	Push Pull, I <sub>OL</sub> = 2mA, V <sub>DD</sub> = 5.0V ± 10%, ipp_hve = 0 (recommended)			0.1V <sub>DD</sub>	V
			Push Pull, I <sub>OL</sub> = 1mA, V <sub>DD</sub> = 5.0V ± 10%, ipp_hve = 1 <sup>3</sup>			0.1V <sub>DD</sub>	
			Push Pull, I <sub>OL</sub> = 1mA, V <sub>DD</sub> = 3.3V ± 10%, ipp_hve = 1 (recommended)			0.5	
T <sub>tr</sub>	CC <sup>4</sup>	Output transition time output pin <sup>5</sup> MEDIUM configuration	C <sub>L</sub> = 25pF, V <sub>DD</sub> = 5.0V ± 10%, ipp_hve = 0			10	ns
			C <sub>L</sub> = 50pF, V <sub>DD</sub> = 5.0V ± 10%, ipp_hve = 0			20	
			C <sub>L</sub> = 100pF, V <sub>DD</sub> = 5.0V ± 10%, ipp_hve = 0			40	
			C <sub>L</sub> = 25pF, V <sub>DD</sub> = 3.3V ± 10%, ipp_hve = 1			12	
			C <sub>L</sub> = 50pF, V <sub>DD</sub> = 3.3V ± 10%, ipp_hve = 1			25	
			C <sub>L</sub> = 100pF, V <sub>DD</sub> = 3.3V ± 10%, ipp_hve = 1			40	
ΔI <sub>tr50</sub>	CC <sup>4</sup>	Current slew at C <sub>L</sub> = 50pF MEDIUM configuration	recommended configuration at V <sub>DD</sub> = 5.0V ± 10%, ipp_hve = 0 V <sub>DD</sub> = 3.3V ± 10%, ipp_hve = 1			7	mA/ns
			V <sub>DD</sub> = 5.0V ± 10%, ipp_hve = 1			16	

<sup>1</sup> V<sub>DD</sub> = 3.3V ± 10% / 5.0V ± 10%, T<sub>A</sub> = -40 to +105°C, unless otherwise specified

<sup>2</sup> All values need to be confirmed during device validation.

<sup>3</sup> This is a transient configuration during power-up. All pads but RESET and NEXUS output (MDOx, EVTO, MCK) are configured in input or in high impedance state.

<sup>4</sup> Data based on characterization results, not tested in production

<sup>5</sup> C<sub>L</sub> calculation should include device and package capacitance (C<sub>PKG</sub> < 5pF).

Table 21. FAST Configuration Output Buffer Electrical Characteristics

Symbol		Parameter	Conditions <sup>1</sup>	Value <sup>2</sup>			Unit
				Min	Typ	Max	
V <sub>OH</sub>	CC	Output high level FAST configuration	Push Pull, I <sub>OH</sub> = -14mA, V <sub>DD</sub> = 5.0V ± 10%, ipp_hve = 0 (recommended)	0.8V <sub>DD</sub>			V
			Push Pull, I <sub>OH</sub> = -7mA, V <sub>DD</sub> = 5.0V ± 10%, ipp_hve = 1 <sup>3</sup>	0.8V <sub>DD</sub>			
			Push Pull, I <sub>OH</sub> = -11mA, V <sub>DD</sub> = 3.3V ± 10%, ipp_hve = 1 (recommended)	V <sub>DD</sub> -0.8			
V <sub>OL</sub>	CC	Output low level FAST configuration	Push Pull, I <sub>OL</sub> = 14mA, V <sub>DD</sub> = 5.0V ± 10%, ipp_hve = 0 (recommended)			0.1V <sub>DD</sub>	V
			Push Pull, I <sub>OL</sub> = 7mA, V <sub>DD</sub> = 5.0V ± 10%, ipp_hve = 1 <sup>3</sup>			0.1V <sub>DD</sub>	
			Push Pull, I <sub>OL</sub> = 11mA, V <sub>DD</sub> = 3.3V ± 10%, ipp_hve = 1 (recommended)			0.5	
T <sub>tr</sub>	CC <sup>4</sup>	Output transition time output pin <sup>5</sup> FAST configuration	C <sub>L</sub> = 25pF, V <sub>DD</sub> = 5.0V ± 10%, ipp_hve = 0			4	ns
			C <sub>L</sub> = 50pF, V <sub>DD</sub> = 5.0V ± 10%, ipp_hve = 0			6	
			C <sub>L</sub> = 100pF, V <sub>DD</sub> = 5.0V ± 10%, ipp_hve = 0			12	
			C <sub>L</sub> = 25pF, V <sub>DD</sub> = 3.3V ± 10%, ipp_hve = 1			4	
			C <sub>L</sub> = 50pF, V <sub>DD</sub> = 3.3V ± 10%, ipp_hve = 1			7	
			C <sub>L</sub> = 100pF, V <sub>DD</sub> = 3.3V ± 10%, ipp_hve = 1			12	
ΔI <sub>tr50</sub> <sup>4</sup>	CC	Current slew at C <sub>L</sub> = 50pF FAST configuration	V <sub>DD</sub> = 5.0V ± 10%, ipp_hve = 0 (recommended configuration)			55	mA/n s
			V <sub>DD</sub> = 3.3V ± 10%, ipp_hve = 1 (recommended configuration)			40	
			V <sub>DD</sub> = 5.0V ± 10%, ipp_hve = 1			100	

<sup>1</sup> V<sub>DD</sub> = 3.3V ± 10% / 5.0V ± 10%, T<sub>A</sub> = -40 to +105°C, unless otherwise specified

<sup>2</sup> All values need to be confirmed during device validation.

<sup>3</sup> This is a transient configuration during power-up. All pads but RESET and NEXUS output (MDOx, EVTO, MCK) are configured in input or in high impedance state.

<sup>4</sup> Data based on characterization results, not tested in production

<sup>5</sup> C<sub>L</sub> calculation should include device and package capacitance (C<sub>PKG</sub> < 5pF).

### 3.6.4 I/O Pad Current Specification

The I/O pads are distributed across the I/O supply segment. Each I/O supply segment is associated to a  $V_{DD}/V_{SS}$  supply pair as described in Table 22.

Table 23 provides I/O consumption figures.

In order to ensure device reliability, the average current of the I/O on a single segment should remain below the  $I_{AVGSEG}$  maximum value.

In order to ensure device functionality, the sum of the dynamic and static current of the I/O on a single segment should remain below the  $I_{DYNSEG}$  maximum value.

**Table 22. I/O Supply Segment**

Package	Supply segment				
	A <sup>1</sup>	B <sup>2</sup>	C <sup>3,4</sup>	D <sup>5</sup>	E <sup>6</sup>
144 LQFP	pins 1 - 21 pins 113 - 144	pins 22 - 52	pins 53 - 72	pins 73 - 102	pins 103 - 112
176 LQFP	pins 1 - 21 pins 143 - 176	pins 22 - 68	pins 69 - 88	pins 89 - 118	pins 119 - 142

<sup>1</sup> LCD pad segment containing pad supplies  $V_{DDE\_A}$

<sup>2</sup> Misc. pad segment containing pad supplies  $V_{DDE\_B}$

<sup>3</sup> ADC pad segment containing pad supplies  $V_{DDE\_C}$

<sup>4</sup> ADC  $V_{DDA}$  and  $V_{DDE\_C}$  should be at the same voltage level

<sup>5</sup> Stepper Motor pad segment containing I/O supplies  $V_{DDMA}$ ,  $V_{DDMB}$ ,  $V_{DDMC}$

<sup>6</sup> Misc pad segment containing pad supplies  $V_{DDE\_E}$

**Table 23. I/O Consumption**

Symbol	Parameter	Conditions <sup>1</sup>	Value <sup>2</sup>			Unit
			Min	Typ	Max	
I <sub>SWTSLW</sub>	CC <sup>3</sup> Dynamic I/O current for SLOW configuration	$C_L = 25\text{pF}$ , $V_{DD} = 5.0\text{V} \pm 10\%$ , $\text{ipp\_hve} = 0$			20	mA
					16	
I <sub>SWTMED</sub>	CC <sup>3</sup> Dynamic I/O current for MEDIUM configuration	$C_L = 25\text{pF}$ , $V_{DD} = 5.0\text{V} \pm 10\%$ , $\text{ipp\_hve} = 0$			29	mA
					17	
I <sub>SWTFST</sub> <sup>3</sup>	CC <sup>3</sup> Dynamic I/O current for FAST configuration	$C_L = 25\text{pF}$ , $V_{DD} = 5.0\text{V} \pm 10\%$ , $\text{ipp\_hve} = 0$			110	mA
					50	

Table 23. I/O Consumption (continued)

Symbol		Parameter	Conditions <sup>1</sup>	Value <sup>2</sup>			Unit
				Min	Typ	Max	
I <sub>RMSLW</sub>	CC	RMS I/O current for SLOW configuration	C <sub>L</sub> = 25 pF, 2 MHz V <sub>DD</sub> = 5.0 V ± 10%, ipp_hve = 0			2.3 <sup>3</sup>	mA
			C <sub>L</sub> = 25 pF, 4 MHz V <sub>DD</sub> = 5.0 V ± 10%, ipp_hve = 0			3.2 <sup>3</sup>	
			C <sub>L</sub> = 100 pF, 2 MHz V <sub>DD</sub> = 5.0 V ± 10%, ipp_hve = 0			6.6 <sup>4</sup>	
			C <sub>L</sub> = 25 pF, 2 MHz V <sub>DD</sub> = 3.3 V ± 10%, ipp_hve = 1			1.6 <sup>3</sup>	
			C <sub>L</sub> = 25 pF, 4 MHz V <sub>DD</sub> = 3.3 V ± 10%, ipp_hve = 1			2.3 <sup>3</sup>	
			C <sub>L</sub> = 100 pF, 2 MHz V <sub>DD</sub> = 3.3 V ± 10%, ipp_hve = 1			4.7 <sup>4</sup>	
I <sub>RMSMED</sub>	CC	Average I/O current for SLOW configuration	C <sub>L</sub> = 25 pF, 2 MHz V <sub>DD</sub> = 5.0 V ± 10%, ipp_hve = 0			6.6 <sup>3</sup>	mA
			C <sub>L</sub> = 25 pF, 4 MHz V <sub>DD</sub> = 5.0 V ± 10%, ipp_hve = 0			13.4 <sup>3</sup>	
			C <sub>L</sub> = 100 pF, 2 MHz V <sub>DD</sub> = 5.0 V ± 10%, ipp_hve = 0			18.3 <sup>4</sup>	
			C <sub>L</sub> = 25 pF, 2 MHz V <sub>DD</sub> = 3.3 V ± 10%, ipp_hve = 1			5.0 <sup>3</sup>	
			C <sub>L</sub> = 25 pF, 4 MHz V <sub>DD</sub> = 3.3 V ± 10%, ipp_hve = 1			8.5 <sup>3</sup>	
			C <sub>L</sub> = 100 pF, 2 MHz V <sub>DD</sub> = 3.3 V ± 10%, ipp_hve = 1			11.0 <sup>4</sup>	
I <sub>RMSFST</sub>	CC	Average I/O current for SLOW configuration	C <sub>L</sub> = 25 pF, 2 MHz V <sub>DD</sub> = 5.0V ± 10%, ipp_hve = 0			22.0 <sup>3</sup>	mA
			C <sub>L</sub> = 25 pF, 4 MHz V <sub>DD</sub> = 5.0V ± 10%, ipp_hve = 0			33.0 <sup>3</sup>	
			C <sub>L</sub> = 100 pF, 2 MHz V <sub>DD</sub> = 5.0V ± 10%, ipp_hve = 0			56.0 <sup>4</sup>	
			C <sub>L</sub> = 25 pF, 2 MHz V <sub>DD</sub> = 3.3V±10%, ipp_hve = 1			14.0 <sup>3</sup>	
			C <sub>L</sub> = 25 pF, 4 MHz V <sub>DD</sub> = 3.3 V ± 10%, ipp_hve = 1			20.0 <sup>3</sup>	
			C <sub>L</sub> = 100 pF, 2 MHz V <sub>DD</sub> = 3.3 V ± 10%, ipp_hve = 1			25.0 <sup>4</sup>	
I <sub>DYNSEG</sub>	SR	Sum of all the dynamic and static I/O current within a supply segment	V <sub>DD</sub> = 5.0 V ± 10%, ipp_hve = 0			110	mA
			V <sub>DD</sub> = 3.3 V ± 10%, ipp_hve = 1			65	
I <sub>AVGSEG</sub>	SR	Sum of all the static I/O current within a supply segment	V <sub>DD</sub> = 5.0 V ± 10%, ipp_hve = 0			70	mA
			V <sub>DD</sub> = 3.3 V ± 10%, ipp_hve = 1			65	



- <sup>1</sup>  $V_{DD} = 3.3\text{ V} \pm 10\% / 5.0\text{ V} \pm 10\%$ ,  $T_A = -40\text{ to }+105^\circ\text{C}$ , unless otherwise specified
- <sup>2</sup> All values need to be confirmed during device validation.
- <sup>3</sup> Data based on simulation results, not tested in production
- <sup>4</sup> Data based on characterization results, not tested in production

### 3.7 **RESET** electrical characteristics

The device implements a dedicated bidirectional RESET pin.

**Figure 7. Start-up reset requirements**

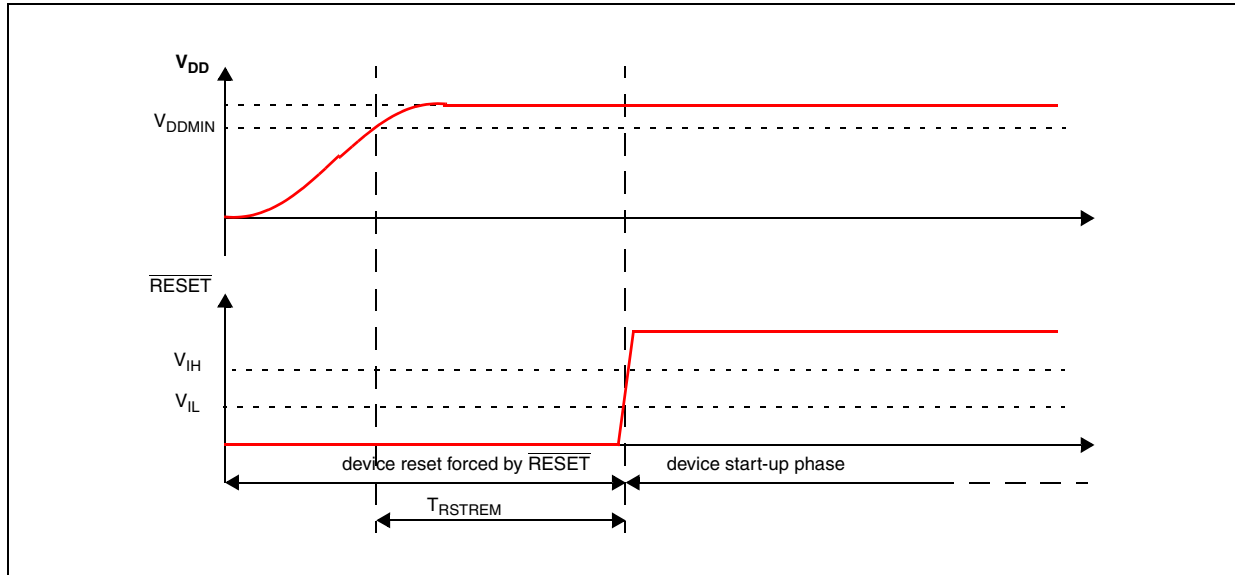

**Figure 8. Noise filtering on reset signal**

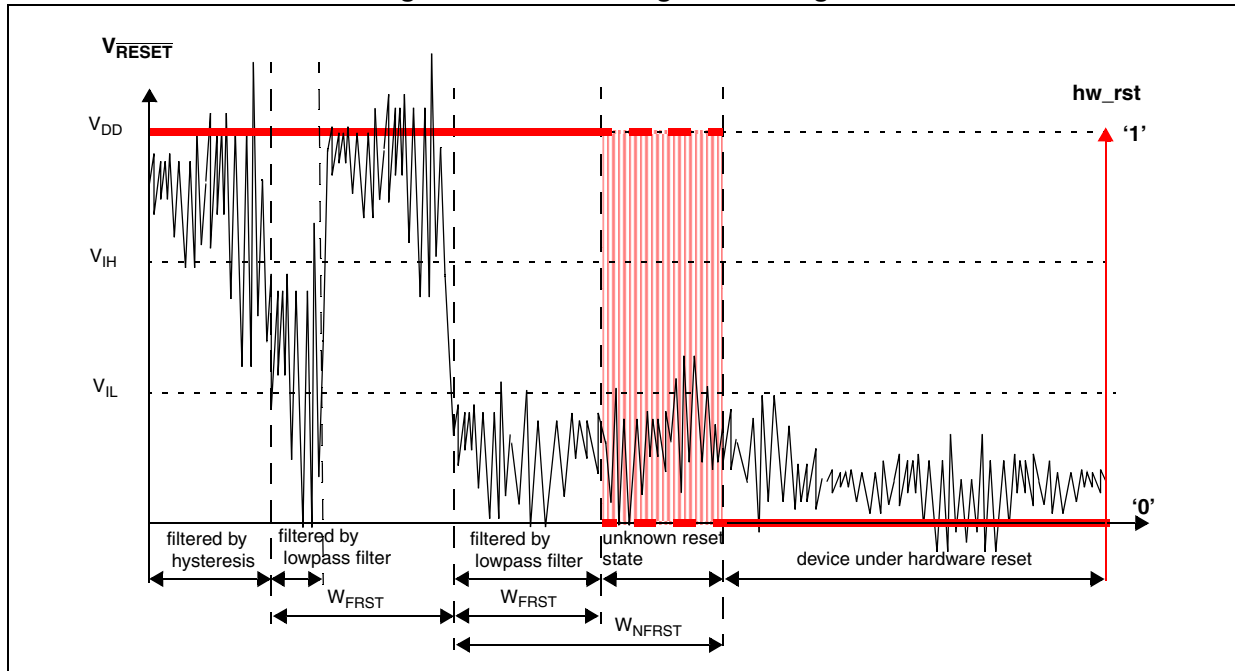

Table 24. Reset electrical characteristics

Symbol		Parameter	Conditions <sup>1</sup>	Value <sup>2</sup>			Unit
				Min	Typ	Max	
V <sub>IH</sub>	SR	Input High Level CMOS Schmitt Trigger		0.65V <sub>DD</sub>		V <sub>DD</sub> +0.4	V
V <sub>IL</sub>	SR	Input low Level CMOS Schmitt Trigger		-0.4		0.35V <sub>DD</sub>	V
V <sub>HYS</sub>	CC <sup>3</sup>	Input hysteresis CMOS Schmitt Trigger		0.1V <sub>DD</sub>			V
V <sub>OL</sub>	CC <sup>4</sup>	Output low level	Push Pull, I <sub>OL</sub> = 2mA, V <sub>DD</sub> = 5.0V ± 10%, ipp_hve = 0 (recommended)			0.1V <sub>DD</sub>	V
			Push Pull, I <sub>OL</sub> = 1mA, V <sub>DD</sub> = 5.0V ± 10%, ipp_hve = 1 <sup>5</sup>			0.1V <sub>DD</sub>	
			Push Pull, I <sub>OL</sub> = 1mA, V <sub>DD</sub> = 3.3V ± 10%, ipp_hve = 1 (recommended)			0.5	
T <sub>tr</sub>	CC <sup>4</sup>	Output transition time output pin <sup>6</sup> MEDIUM configuration	C <sub>L</sub> = 25pF, V <sub>DD</sub> = 5.0V ± 10%, ipp_hve = 0			10	ns
			C <sub>L</sub> = 50pF, V <sub>DD</sub> = 5.0V ± 10%, ipp_hve = 0			20	
			C <sub>L</sub> = 100pF, V <sub>DD</sub> = 5.0V ± 10%, ipp_hve = 0			40	
			C <sub>L</sub> = 25pF, V <sub>DD</sub> = 3.3V ± 10%, ipp_hve = 1			12	
			C <sub>L</sub> = 50pF, V <sub>DD</sub> = 3.3V ± 10%, ipp_hve = 1			25	
			C <sub>L</sub> = 100pF, V <sub>DD</sub> = 3.3V ± 10%, ipp_hve = 1			40	
W <sub>FRST</sub>	SR	RESET Input Filtered Pulse		-		40	ns
W <sub>NFRS</sub> T	SR	RESET Input Not Filtered Pulse		1000	-	-	ns
I <sub>WPU</sub>	CC <sup>4</sup>	Weak pull-up current absolute value		10			μA

<sup>1</sup> V<sub>DD</sub> = 3.3V ± 10% / 5.0V ± 10%, T<sub>A</sub> = -40 / +105°C, unless otherwise specified

<sup>2</sup> All values need to be confirmed during device validation.

<sup>3</sup> Data based on characterization results, not tested in production

<sup>4</sup> Guaranteed by design simulation.

<sup>5</sup> This is a transient configuration during power-up, up to the end of reset PHASE2 (refer to RGM module section of the reference manual).

<sup>6</sup> C<sub>L</sub> calculation should include device and package capacitance (C<sub>PKG</sub> < 5pF).

### 3.8 Main Oscillator Electrical Characteristics

The device provides an oscillator/resonator driver. Figure 9 describes a simple model of the internal oscillator driver and provides an example of a connection for an oscillator or a resonator.

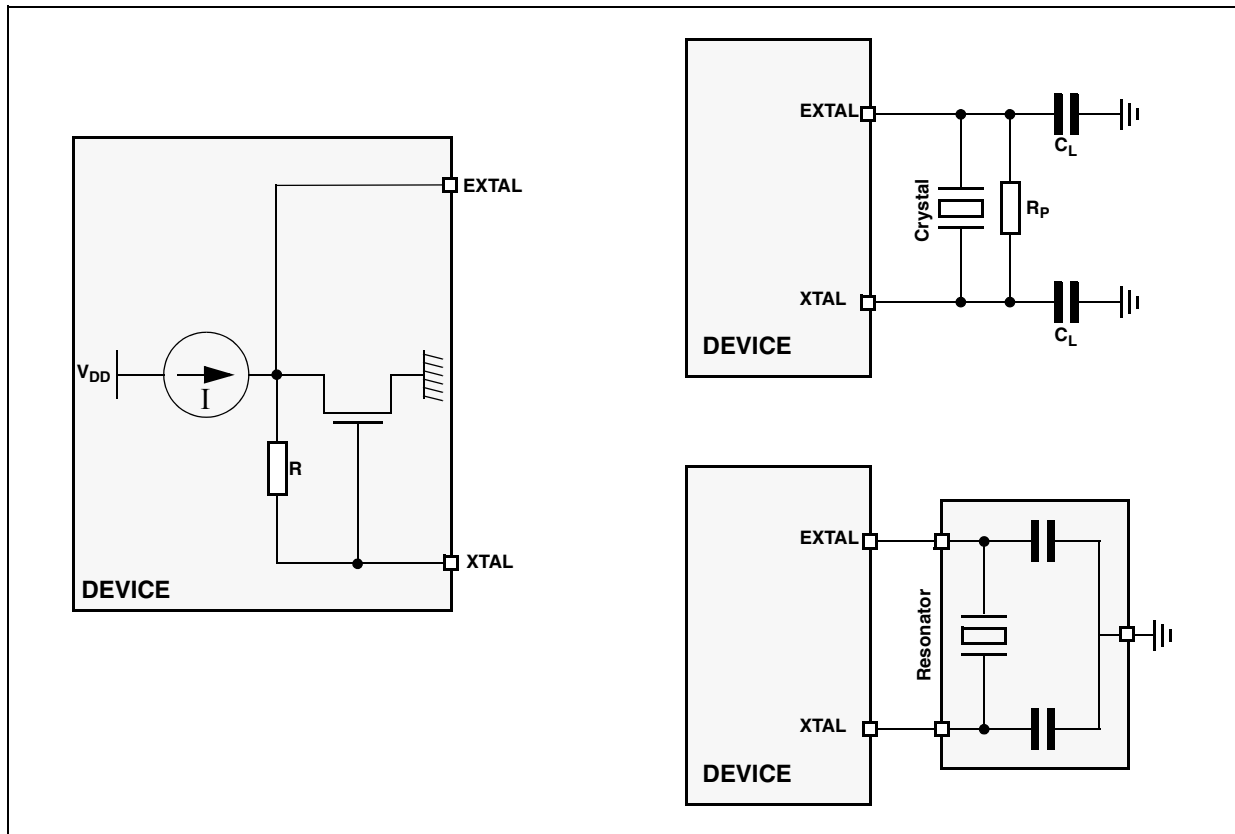

Figure 9. Crystal Oscillator and Resonator Connection Scheme

#### NOTE

XTAL/EXTAL must not be directly used to drive external circuits.

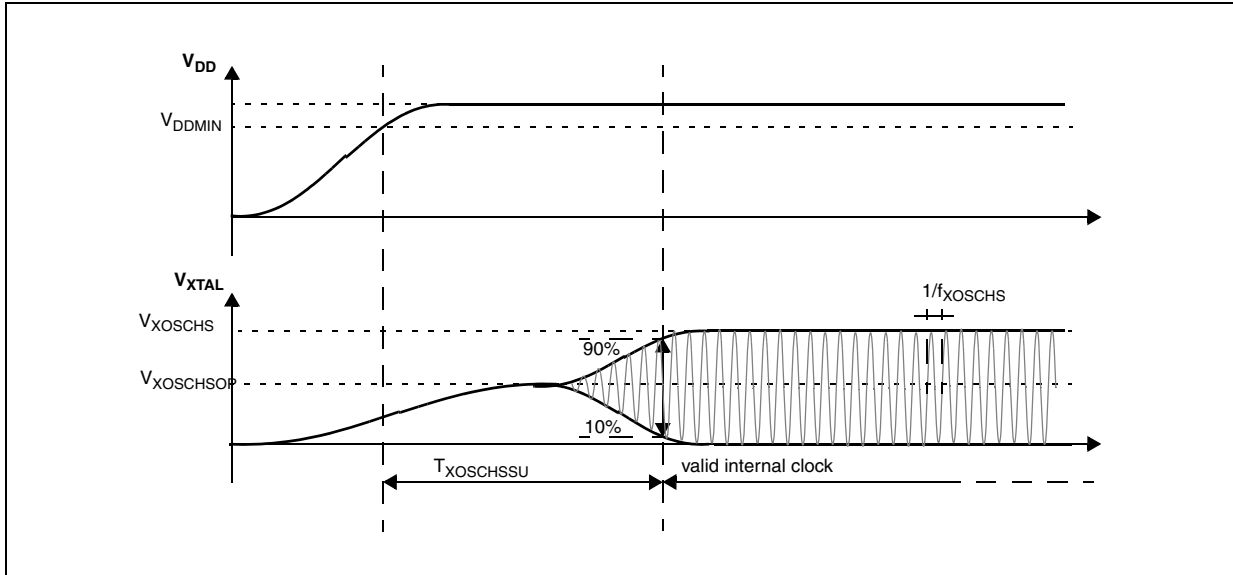

Figure 10. Main Oscillator Electrical Characteristics

Table 25. Main Oscillator Electrical Characteristics

Symbol		Parameter	Conditions <sup>1</sup>	Value <sup>2</sup>			Unit	
				Min	Typ	Max		
$f_{XOSCHS}$	SR	Oscillator frequency		4.0	—	16.0	MHz	
$g_{mXOSCHS}$	CC <sup>3</sup>	Oscillator transconductance	$V_{DD} = 3.3\text{ V} \pm 10\%$ , OSCILLATOR_MARGIN = 0	4.11	5.59	7.38	mA/V	
			$V_{DD} = 5.0\text{ V} \pm 10\%$ , OSCILLATOR_MARGIN = 0	3.67	5.04	6.73		
			$V_{DD} = 3.3\text{ V} \pm 10\%$ , OSCILLATOR_MARGIN = 1	4.93	6.70	8.86		
			$V_{DD} = 5.0\text{ V} \pm 10\%$ , OSCILLATOR_MARGIN = 1	4.54	6.22	8.31		
$V_{XOSCHS}$	CC <sup>3</sup>	Oscillation amplitude	$f_{OSC} = 4\text{ MHz}$ , $V_{DD} = 3.3\text{ V} \pm 10\%$	2.51	—	—	V	
			$f_{OSC} = 16\text{ MHz}$ , $V_{DD} = 3.3\text{ V} \pm 10\%$	1.68	—	—		
			$f_{OSC} = 4\text{ MHz}$ , $V_{DD} = 5.0\text{ V} \pm 10\%$	4.74	—	—		
			$f_{OSC} = 16\text{ MHz}$ , $V_{DD} = 5.0\text{ V} \pm 10\%$	3.02	—	—		
$V_{XOSCHSOP}$	CC <sup>3</sup>	Oscillation operating point	$V_{DD} = 3.3\text{ V} \pm 10\%$	$V_{EXTAL}$	0.894	—	1.143	V
				$V_{XTAL}$	0.894	—	1.146	
			$V_{DD} = 5.0\text{ V} \pm 10\%$	$V_{EXTAL}$	0.904	—	1.166	
				$V_{XTAL}$	0.904	—	1.169	

Table 25. Main Oscillator Electrical Characteristics (continued)

Symbol	Parameter	Conditions <sup>1</sup>	Value <sup>2</sup>			Unit	
			Min	Typ	Max		
I <sub>XOSCHS</sub>	CC <sup>3</sup>	Oscillator consumption	f <sub>OSC</sub> = 4 MHz	—	—	2.43	mA
			f <sub>OSC</sub> = 16 MHz	—	—	2.52	
T <sub>XOSCHSSU</sub>	CC <sup>3</sup>	Oscillator start-up time	f <sub>OSC</sub> = 4 MHz, OSCILLATOR_MARGIN = 0	—	—	6.0	ms
			f <sub>OSC</sub> = 16 MHz, OSCILLATOR_MARGIN = 1	—	—	1.8	
V <sub>IH</sub>	SR	Input high level CMOS Schmitt Trigger	Oscillator bypass mode	0.65V <sub>DD</sub>		V <sub>DD</sub> +0.4	V
V <sub>IL</sub>	SR	Input low level CMOS Schmitt Trigger	Oscillator bypass mode	-0.4		0.35V <sub>DD</sub>	V

<sup>1</sup> V<sub>DD</sub> = 3.3 V ± 10% / 5.0 V ± 10%, T<sub>A</sub> = -40 to +105 °C, unless otherwise specified

<sup>2</sup> All values need to be confirmed during device validation.

<sup>3</sup> Data based on simulation results, not tested in production

### 3.9 Low Power Oscillator Electrical Characteristics

The device provides a low power oscillator/resonator driver.

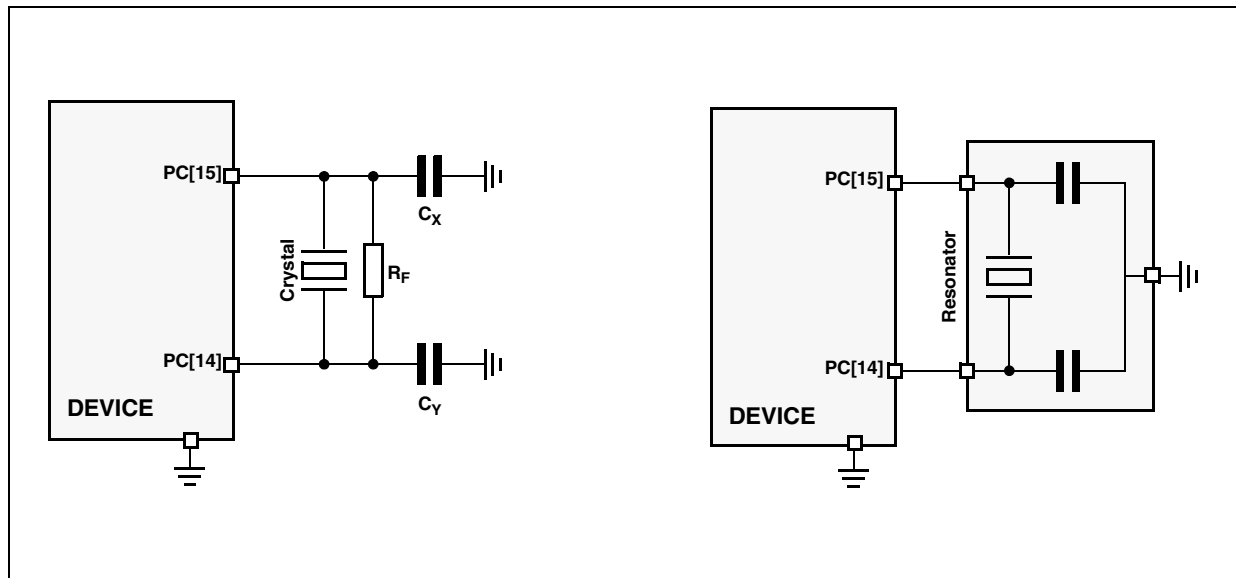

Figure 11. Crystal Oscillator and Resonator Connection Scheme

#### NOTE

PC[14]/PC[15] must not be directly used to drive external circuits.

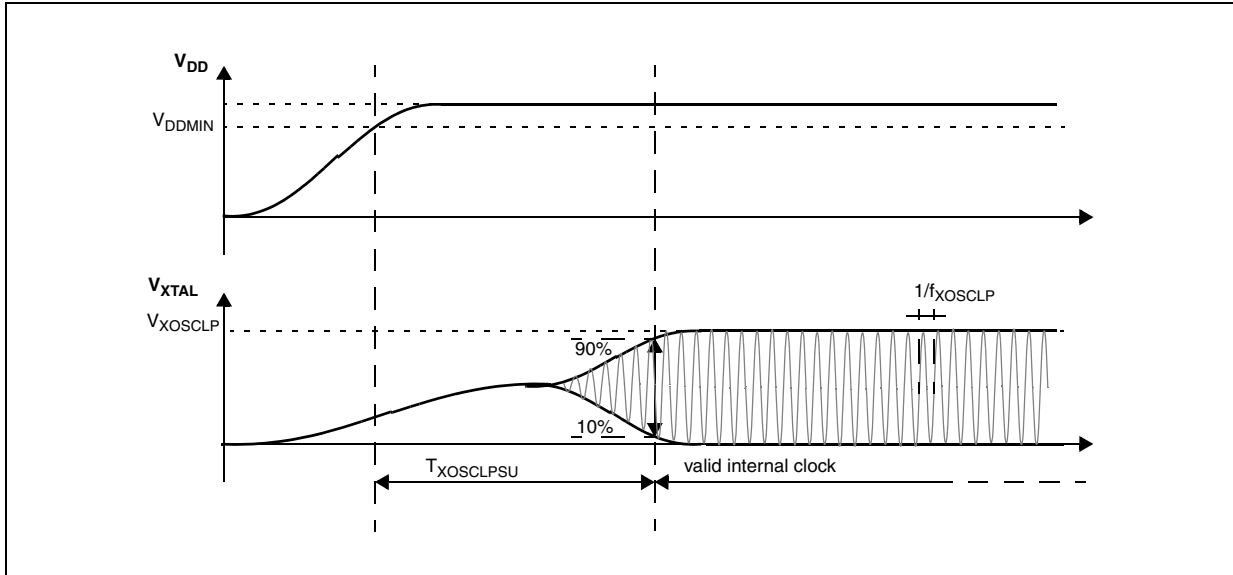

Figure 12. Low Power Oscillator Electrical Characteristics

Table 26. Low Power Oscillator Electrical Characteristics

Symbol	Parameter	Conditions <sup>1</sup>	Value <sup>2</sup>			Unit	
			Min	Typ	Max		
f <sub>XOSCLP</sub>	SR	Oscillator frequency	32	-	40	kHz	
V <sub>XOSCLP</sub>	CC <sup>3</sup>	Oscillation amplitude	V <sub>DD</sub> =3.3V±10%,	1.12	1.33	1.74	V
			V <sub>DD</sub> =5.0V±10%,	1.12	1.37	1.74	
I <sub>XOSCLP</sub>	CC <sup>3</sup>	Oscillator consumption			5	µA	
T <sub>XOSCLPSU</sub>	CC <sup>3</sup>	Oscillator start-up time			2	s	
V <sub>IH</sub>	SR	Input high level CMOS Schmitt Trigger	Oscillator bypass mode	0.65V <sub>DD</sub>		V <sub>DD</sub> +0.4	V
V <sub>IL</sub>	SR	Input low level CMOS Schmitt Trigger	Oscillator bypass mode	-0.4		0.35V <sub>DD</sub>	V

<sup>1</sup> V<sub>DD</sub> = 3.3 V ± 10% / 5.0 V ± 10%, T<sub>A</sub> = -40 to +105 °C, unless otherwise specified

<sup>2</sup> All values need to be confirmed during device validation.

<sup>3</sup> Granted by device validation

### 3.10 FMPLL Electrical Characteristics

The device provides a frequency-modulated phase-locked loop (FMPLL) module to generate a fast system clock from the main oscillator driver.

Table 27. FMPLL Electrical Characteristics

Symbol		Parameter	Conditions <sup>1</sup>	Value <sup>2</sup>			Unit
				Min	Typ	Max	
f <sub>PLLIN</sub>	SR	PLL reference clock <sup>3</sup>		4		64	MHz
Δ <sub>PLLIN</sub>	SR	PLL reference clock duty cycle <sup>3</sup>		40		60	%
f <sub>PLLOUT</sub>	CC <sup>4</sup>	PLL output clock frequency		16		64	MHz
f <sub>CPU</sub>	CC <sup>4</sup>	System clock frequency				64 <sup>5</sup>	MHz
T <sub>LOCK</sub>	CC <sup>4</sup>	PLL lock time	Stable oscillator (f <sub>PLLIN</sub> = 16 MHz)			200	μs
ΔT <sub>PKJIT</sub>	CC <sup>4</sup>	PLL jitter (pk to pk)	f <sub>PLLIN</sub> = 16 MHz (resonator)			500	ps
ΔT <sub>LTJIT</sub>	CC <sup>4</sup>	PLL long term jitter	f <sub>PLLIN</sub> = 16 MHz (resonator)			1.5	ns
I <sub>PLL</sub>	CC <sup>6</sup>	Oscillator consumption	T <sub>A</sub> = 25 °C			4	mA

<sup>1</sup> V<sub>DDPLL</sub> = 1.2 V ± 10%, T<sub>A</sub> = -40 to +105 °C, unless otherwise specified.

<sup>2</sup> All values need to be confirmed during device validation.

<sup>3</sup> PLLIN clock retrieved directly from XOSCHS clock. Input characteristics are granted when oscillator is used in functional mode. When bypass mode is used, oscillator input clock should verify f<sub>PLLIN</sub> and Δ<sub>PLLIN</sub>.

<sup>4</sup> Data based on device simulation.

<sup>5</sup> f<sub>CPU</sub> 64 MHz can be achieved only at up to 105 °C

<sup>6</sup> Data based on characterization results, not tested in production

### 3.11 Main RC Oscillator Electrical Characteristics

The device provides a 16 MHz internal RC oscillator. This is used as the default clock at the power-up of the device.

Table 28. Main RC Oscillator Electrical Characteristics

Symbol		Parameter	Conditions <sup>1</sup>	Value <sup>2</sup>			Unit
				Min	Typ	Max	
f <sub>RCM</sub>	CC <sup>3</sup>	RC oscillator high frequency	T <sub>A</sub> = 25 °C, trimmed		16		MHz
I <sub>RCMRUN</sub>	CC <sup>3</sup>	RC oscillator high frequency current in running mode	T <sub>A</sub> = 25 °C, trimmed			200	μA
I <sub>RCMPWD</sub>	CC <sup>3</sup>	RC oscillator high frequency current in power down mode	T <sub>A</sub> = 25 °C			10	μA
ΔRCMTRIM	CC <sup>3</sup>	RC oscillator precision after trimming of f <sub>RC</sub>	T <sub>A</sub> = 25 °C	-1		+1	%
ΔRCMVAR	CC <sup>4</sup>	RC oscillator variation in temperature and supply with respect to f <sub>RC</sub> at T <sub>A</sub> = 55 °C in high-frequency configuration		-5		+5	%

<sup>1</sup> V<sub>DD</sub> = 3.3 V ± 10% / 5.0 V ± 10%, T<sub>A</sub> = -40 to +105 °C, unless otherwise specified.

<sup>2</sup> All values need to be confirmed during device validation.

<sup>3</sup> Guaranteed by device simulation, not tested in production

<sup>4</sup> Guaranteed by device characterization, not tested in production

### 3.12 Low Power RC Oscillator Electrical Characteristics

The device provides a low power internal RC oscillator. This can be used as the reference clock for the RTC module.

**Table 29. Low Power RC Oscillator Electrical Characteristics**

Symbol		Parameter	Conditions <sup>1</sup>	Value <sup>2</sup>			Unit
				Min	Typ	Max	
$f_{RCL}$	CC <sup>3</sup>	RC oscillator low frequency	$T_A = 25\text{ }^\circ\text{C}$ , trimmed		128		kHz
$I_{RCL}$	CC <sup>3</sup>	RC oscillator low frequency current	$T_A = 25\text{ }^\circ\text{C}$ , trimmed			5	$\mu\text{A}$
$\Delta RCLTRIM$	CC <sup>3</sup>	RC oscillator precision after trimming of $f_{RCL}$	$T_A = 25\text{ }^\circ\text{C}$	-2		+2	%
$\Delta RCLVAR$ <sup>3</sup>	CC <sup>3</sup>	RC oscillator variation in temperature and supply with respect to $f_{RC}$ at $T_A = 55\text{ }^\circ\text{C}$ in high frequency configuration	High frequency configuration	-10		+10	%

<sup>1</sup>  $V_{DD} = 3.3\text{ V} \pm 10\% / 5.0\text{ V} \pm 10\%$ ,  $T_A = -40\text{ to }+105\text{ }^\circ\text{C}$ , unless otherwise specified.

<sup>2</sup> All values need to be confirmed during device validation.

<sup>3</sup> Guaranteed by device simulation, not tested in production

### 3.13 Flash Memory Electrical Characteristics

**Table 30. Program and Erase Specifications**

Symbol	Parameter	Min Value	Typical Value <sup>1</sup>	Initial Max <sup>2</sup>	Max <sup>3</sup>	Unit
$T_{dwprogram}$	Double Word (64 bits) Program Time <sup>4</sup>		—	22	500	$\mu\text{s}$
$T_{16kpperase}$	16 KB Block Pre-program and Erase Time		—	500	5000	ms
$T_{32kpperase}$	32 KB Block Pre-program and Erase Time		—	600	5000	ms
$T_{128kpperase}$	128 KB Block Pre-program and Erase Time		—	1300	7500	ms

<sup>1</sup> Typical program and erase times assume nominal supply values and operation at  $25\text{ }^\circ\text{C}$ . All times are subject to change pending device characterization.

<sup>2</sup> Initial factory condition: < 100 program/erase cycles,  $25\text{ }^\circ\text{C}$ , typical supply voltage.

<sup>3</sup> The maximum program & erase times occur after the specified number of program/erase cycles. These maximum values are characterized but not guaranteed.

<sup>4</sup> Actual hardware programming times. This does not include software overhead.



Table 31. Flash Module Life

Symbol	Parameter	Conditions	Value		Unit
			Min	Typ	
P/E	Number of program/erase cycles per block for 16 Kbyte blocks over the operating temperature range ( $T_J$ )	—	100,000	—	cycles
P/E	Number of program/erase cycles per block for 32 Kbyte blocks over the operating temperature range ( $T_J$ )	—	10,000	100,000 (TBD)	cycles
P/E	Number of program/erase cycles per block for 128 Kbyte blocks over the operating temperature range ( $T_J$ )	—	1,000	100,000 (TBD)	cycles
Retention	Minimum data retention at 85 °C average ambient temperature <sup>1</sup>	Blocks with 0 - 1,000 P/E cycles	20	—	years
		Blocks with 10,000 P/E cycles	10	—	years
		Blocks with 100,000 P/E cycles	1 - 5 (TBD)	—	years

<sup>1</sup> Ambient temperature averaged over duration of application, not to exceed recommended product operating temperature range.

### 3.14 Analog to Digital Converter (ADC) Electrical Characteristics

The device provides a 10-bit Successive Approximation Register (SAR) Analog to Digital Converter.

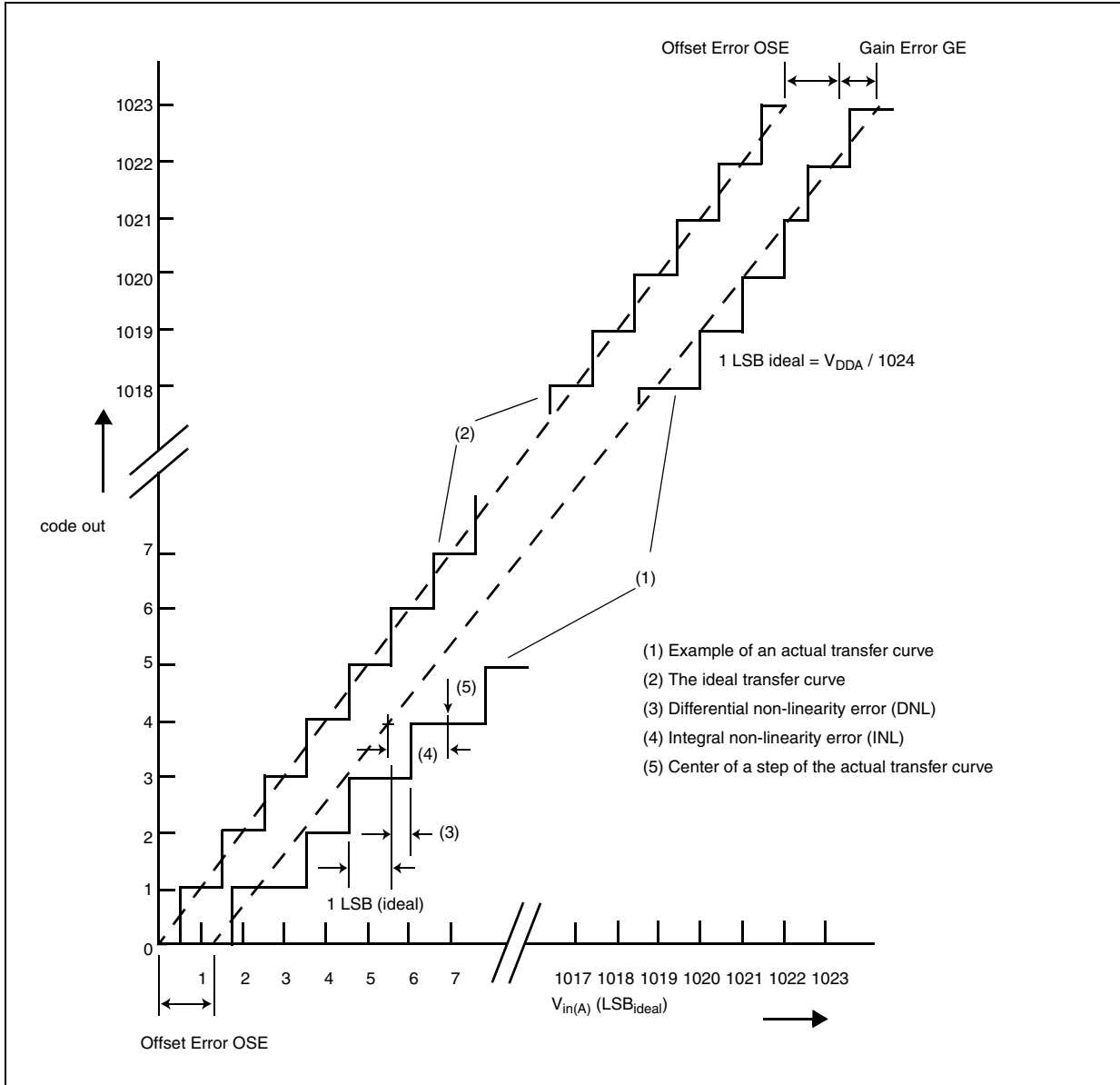

Figure 13. ADC Characteristics and Error Definitions

### 3.14.1 Input Impedance and ADC Accuracy

In the following analysis, the input circuit corresponding to the precise channels is considered.

To preserve the accuracy of the A/D converter, it is necessary that analog input pins have low AC impedance. Placing a capacitor with good high frequency characteristics at the input pin of the device can be effective: the capacitor should be as large as possible, ideally infinite. This capacitor contributes to attenuating the noise present on the input pin; furthermore, it sources charge during the sampling phase, when the analog signal source is a high-impedance source.

A real filter can typically be obtained by using a series resistance with a capacitor on the input pin (simple RC filter). The RC filtering may be limited according to the value of source impedance of the transducer or circuit supplying the analog signal to be measured. The filter at the input pins must be designed taking into account the dynamic characteristics of the input signal (bandwidth) and the equivalent input impedance of the ADC itself.

In fact a current sink contributor is represented by the charge sharing effects with the sampling capacitance:  $C_S$  being substantially a switched capacitance, with a frequency equal to the conversion rate of the ADC, it can be seen as a resistive path to ground. For instance, assuming a conversion rate of 1 MHz, with  $C_S$  equal to 3 pF, a resistance of 330k $\Omega$  is obtained ( $R_{EQ} = 1 / (f_c * C_S)$ ), where  $f_c$  represents the conversion rate at the considered channel). To minimize the error induced by the voltage partitioning between this resistance (sampled voltage on  $C_S$ ) and the sum of  $R_S + R_F + R_L + R_{SW} + R_{AD}$ , the external circuit must be designed to respect the [Equation 5](#):

Eqn. 5

$$V_A \cdot \frac{R_S + R_F + R_L + R_{SW} + R_{AD}}{R_{EQ}} < \frac{1}{2} \text{LSB}$$

[Equation 5](#) generates a constraint for external network design, in particular on resistive path. Internal switch resistances ( $R_{SW}$  and  $R_{AD}$ ) can be neglected with respect to external resistances.

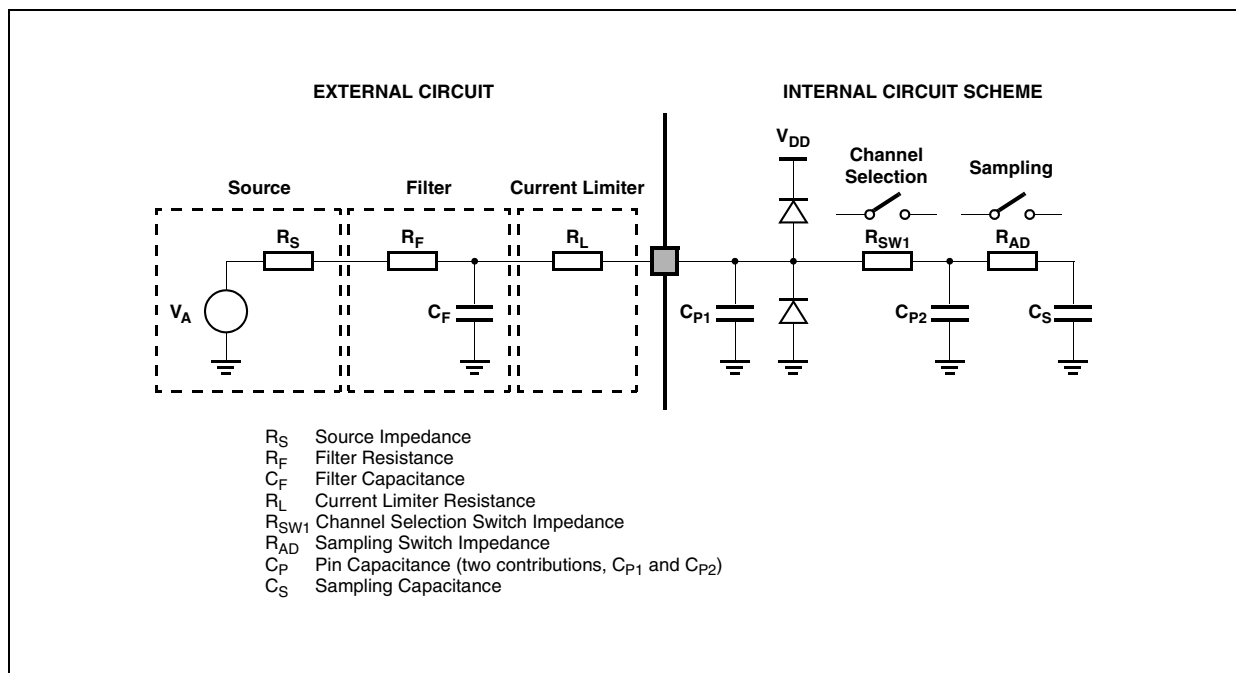

Figure 14. Input Equivalent Circuit (Precise Channels)

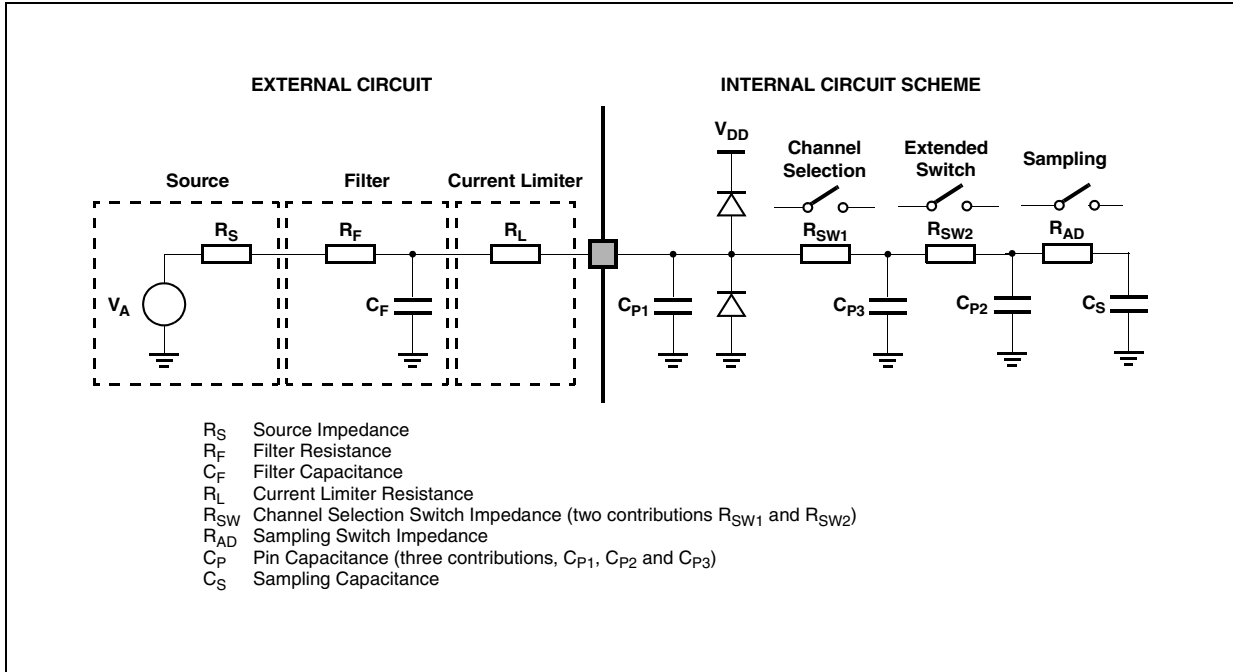

Figure 15. Input Equivalent Circuit (Extended Channels)

A second aspect involving the capacitance network shall be considered. Assuming the three capacitances  $C_F$ ,  $C_{P1}$  and  $C_{P2}$  are initially charged at the source voltage  $V_A$  (refer to the equivalent circuit reported in Figure 14): A charge sharing phenomenon is installed when the sampling phase is started (A/D switch close).

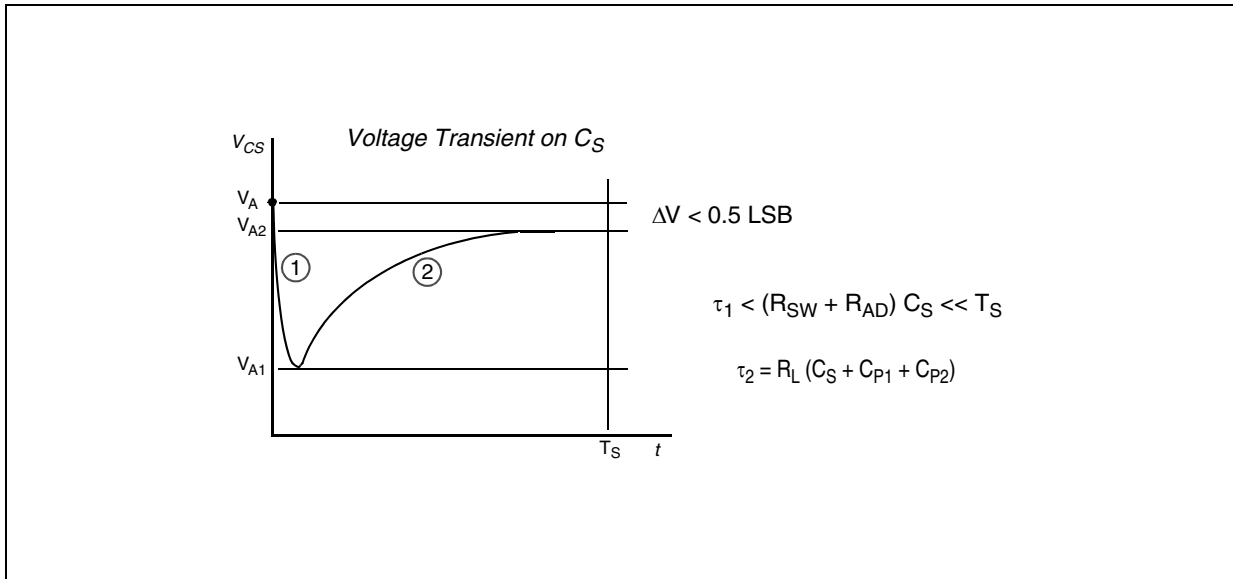

Figure 16. Transient Behavior during Sampling Phase

In particular two different transient periods can be distinguished:

- A first and quick charge transfer from the internal capacitance  $C_{P1}$  and  $C_{P2}$  to the sampling capacitance  $C_S$  occurs ( $C_S$  is supposed initially completely discharged): considering a worst case (since the time constant in reality would be faster) in which  $C_{P2}$  is reported in parallel to  $C_{P1}$  (call  $C_P = C_{P1} + C_{P2}$ ), the two capacitances  $C_P$  and  $C_S$  are in series, and the time constant is

**Eqn. 6**

$$\tau_1 = (R_{SW} + R_{AD}) \cdot \frac{C_P \cdot C_S}{C_P + C_S}$$

Equation 6 can again be simplified considering only  $C_S$  as an additional worst condition. In reality, the transient is faster, but the A/D converter circuitry has been designed to be robust also in the very worst case: the sampling time  $T_S$  is always much longer than the internal time constant:

**Eqn. 7**

$$\tau_1 < (R_{SW} + R_{AD}) \cdot C_S \ll T_S$$

The charge of  $C_{P1}$  and  $C_{P2}$  is redistributed also on  $C_S$ , determining a new value of the voltage  $V_{A1}$  on the capacitance according to Equation 8:

**Eqn. 8**

$$V_{A1} \cdot (C_S + C_{P1} + C_{P2}) = V_A \cdot (C_{P1} + C_{P2})$$

- A second charge transfer involves also  $C_F$  (that is typically bigger than the on-chip capacitance) through the resistance  $R_L$ : again considering the worst case in which  $C_{P2}$  and  $C_S$  were in parallel to  $C_{P1}$  (since the time constant in reality would be faster), the time constant is:

**Eqn. 9**

$$\tau_2 < R_L \cdot (C_S + C_{P1} + C_{P2})$$

In this case, the time constant depends on the external circuit: in particular imposing that the transient is completed well before the end of sampling time  $T_S$ , a constraints on  $R_L$  sizing is obtained:

**Eqn. 10**

$$10 \cdot \tau_2 = 10 \cdot R_L \cdot (C_S + C_{P1} + C_{P2}) < T_S$$

Of course,  $R_L$  shall be sized also according to the current limitation constraints, in combination with  $R_S$  (source impedance) and  $R_F$  (filter resistance). Being  $C_F$  definitively bigger than  $C_{P1}$ ,  $C_{P2}$  and  $C_S$ , then the final voltage  $V_{A2}$  (at the end of the charge transfer transient) will be much higher than  $V_{A1}$ . Equation 11 must be respected (charge balance assuming now  $C_S$  already charged at  $V_{A1}$ ):

**Eqn. 11**

$$V_{A2} \cdot (C_S + C_{P1} + C_{P2} + C_F) = V_A \cdot C_F + V_{A1} \cdot (C_{P1} + C_{P2} + C_S)$$

The two transients above are not influenced by the voltage source that, due to the presence of the  $R_F C_F$  filter, is not able to provide the extra charge to compensate the voltage drop on  $C_S$  with respect to the ideal source  $V_A$ ; the time constant  $R_F C_F$  of the filter is very high with respect to the sampling time ( $T_S$ ). The filter is typically designed to act as anti-aliasing.

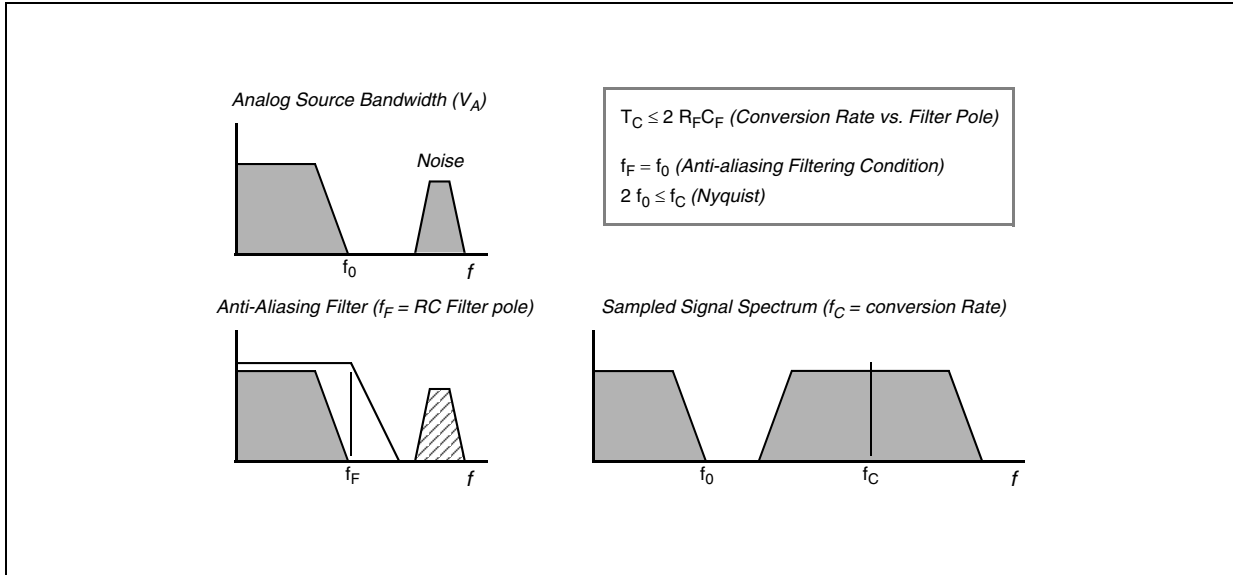

**Figure 17. Spectral Representation of Input Signal**

Calling  $f_0$  the bandwidth of the source signal (and as a consequence the cut-off frequency of the anti-aliasing filter,  $f_F$ ), according to the Nyquist theorem the conversion rate  $f_C$  must be at least  $2f_0$ ; it means that the constant time of the filter is greater than or at least equal to twice the conversion period ( $T_C$ ). Again the conversion period  $T_C$  is longer than the sampling time  $T_S$ , which is just a portion of it, even when fixed channel continuous conversion mode is selected (fastest conversion rate at a specific channel): in conclusion it is evident that the time constant of the filter  $R_F C_F$  is definitively much higher than the sampling time  $T_S$ , so the charge level on  $C_S$  cannot be modified by the analog signal source during the time in which the sampling switch is closed.

The considerations above lead to impose new constraints on the external circuit, to reduce the accuracy error due to the voltage drop on  $C_S$ ; from the two charge balance equations above, it is simple to derive Equation 12 between the ideal and real sampled voltage on  $C_S$ :

**Eqn. 12**

$$\frac{V_A}{V_{A2}} = \frac{C_{P1} + C_{P2} + C_F}{C_{P1} + C_{P2} + C_F + C_S}$$

From this formula, in the worst case (when  $V_A$  is maximum, that is for instance 5V), assuming to accept a maximum error of half a count, a constraint is evident on  $C_F$  value:

**Eqn. 13**

$$C_F > 2048 \cdot C_S$$

### 3.14.2 ADC Electrical Characteristics

Table 32. ADC Electrical Characteristics

Symbol		Parameter	Conditions <sup>1</sup>	Value <sup>2</sup>			Unit
				Min	Typ	Max	
V <sub>SSA</sub>	SR	Voltage on VSSA (ADC reference) pin with respect to ground (V <sub>SS</sub> ) <sup>3</sup>		-0.1		0.1	V
V <sub>DDA</sub>	SR	Voltage on VDDA pin (ADC reference) with respect to ground (V <sub>SS</sub> )		V <sub>DD</sub> -0.1		V <sub>DD</sub> +0.1	V
V <sub>AINx</sub>	SR	Analog input voltage <sup>4</sup>		V <sub>SSA</sub> -0.1		V <sub>DDA</sub> +0.1	V
f <sub>ADC</sub>	SR	ADC analog frequency		6		32	MHz
t <sub>ADC_PU</sub>	SR	ADC power up delay				1.5	μs
t <sub>ADC_S</sub>	CC <sup>5</sup>	Sample time <sup>6</sup>	f <sub>ADC</sub> = 32 MHz, ADC_conf_sample_input = 17	0.5			μs
			f <sub>ADC</sub> = 6 MHz, ADC_conf_sample_input = 127			21	
t <sub>ADC_C</sub>	CC <sup>5</sup>	Conversion time <sup>7</sup>	f <sub>ADC</sub> = 32 MHz, ADC_conf_comp = 2	0.625			μs
C <sub>S</sub>	CC <sup>5</sup>	ADC input sampling capacitance				3	pF
C <sub>P1</sub>	CC <sup>5</sup>	ADC input pin capacitance 1				3	pF
C <sub>P2</sub>	CC <sup>5</sup>	ADC input pin capacitance 2				1	pF
C <sub>P3</sub>	CC <sup>5</sup>	ADC input pin capacitance 3				1	pF
R <sub>SW1</sub>	CC <sup>5</sup>	Internal resistance of analog source				3	kΩ
R <sub>SW2</sub>	CC <sup>5</sup>	Internal resistance of analog source				2	kΩ
R <sub>AD</sub>	CC <sup>5</sup>	Internal resistance of analog source				0.1	kΩ
I <sub>INJ</sub>	SR	Input current Injection	Current injection on one ADC input, different from the converted one	-10		10	mA
INL	CC <sup>5</sup>	Integral Non Linearity	No overload	-1.5		1.5	LSB
DNL	CC <sup>5</sup>	Differential Non Linearity	No overload	-1.0		1.0	LSB
OFS	CC <sup>5</sup>	Offset error	After offset cancellation	-1.0		1.0	LSB
GNE	CC <sup>5</sup>	Gain error		-1.0		1.0	LSB

Table 32. ADC Electrical Characteristics (continued)

Symbol		Parameter	Conditions <sup>1</sup>	Value <sup>2</sup>			Unit
				Min	Typ	Max	
TUEP	CC <sup>5</sup>	Total Unadjusted Error for precise channels, input only pins	No overload	-2		2	LSB
			overload conditions on adjacent channel				LSB
TUEX	CC <sup>5</sup>	Total Unadjusted Error for extended channel,	No overload	-3		3	LSB
			overload conditions on adjacent channel				LSB

<sup>1</sup> V<sub>DDA</sub> = 3.3 V ± 10% / 5.0 V ± 10%, T<sub>A</sub> = -40 to +105 °C, unless otherwise specified.

<sup>2</sup> All values need to be confirmed during device validation.

<sup>3</sup> Analog and digital V<sub>SS</sub> **must** be common (to be tied together externally).

<sup>4</sup> V<sub>AINx</sub> may exceed V<sub>SSA</sub> and V<sub>DDA</sub> limits, remaining on absolute maximum ratings, but the results of the conversion will be clamped respectively to 0x000 or 0x3FF

<sup>5</sup> Guaranteed by design

<sup>6</sup> During the sample time the input capacitance C<sub>S</sub> can be charged/discharged by the external source. The internal resistance of the analog source must allow the capacitance to reach its final voltage level within t<sub>ADC\_S</sub>. After the end of the sample time t<sub>ADC\_S</sub>, changes of the analog input voltage have no effect on the conversion result. Values for the sample clock t<sub>ADC\_S</sub> depend on programming.

<sup>7</sup> This parameter does not include the sample time t<sub>ADC\_S</sub>, but only the time for determining the digital result and the time to load the result's register with the conversion result.

### 3.15 AC Specifications

#### 3.15.1 Pad AC Specifications

Table 33. Pad AC specifications (5.0 V, IPP\_HVE=1)<sup>1</sup>

Num	Pad	Tswitchon <sup>1</sup> (ns)			Rise/Fall <sup>2</sup> (ns)			Frequency (MHz)			Current slew <sup>3</sup> (mA/ns)			Load drive (pF)
		Min	Typ	Max	Min	Typ	Max	Min	Typ	Max	Min	Typ	Max	
1	Slow	1.5	-	30	6	-	50	-	-	4	0.04	-	2	25
		1.5	-	30	9	-	100	-	-	2	0.04	-	2	50
		1.5	-	30	12	-	125	-	-	2	0.04	-	2	100
		1.5	-	30	16	-	150	-	-	2	0.04	-	2	200
2	Medium	1	-	15	3	-	10	-	-	40	2.5	-	7	25
		1	-	15	5	-	20	-	-	20	2.5	-	7	50
		1	-	15	9	-	40	-	-	13	2.5	-	8	100
		1	-	15	12	-	70	-	-	7	2.5	-	8	200



Table 33. Pad AC specifications (5.0 V, IPP\_HVE=1)<sup>1</sup> (continued)

Num	Pad	Tswitchon <sup>1</sup> (ns)			Rise/Fall <sup>2</sup> (ns)			Frequency (MHz)			Current slew <sup>3</sup> (mA/ns)			Load drive (pF)
		Min	Typ	Max	Min	Typ	Max	Min	Typ	Max	Min	Typ	Max	
3	Fast	1	-	6	1	-	4	-	-	100	18	-	55	25
		1	-	6	1.5	-	6	-	-	80	18	-	55	50
		1	-	6	3	-	12	-	-	40	18	-	55	100
		1	-	6	5	-	16	-	-	25	18	-	55	200
4	Symmetric	1	-	5	1	-	4	-	-	50	10	-	25	25
5	Pull Up/Down (5.5 V max)	-	-	-	-	-	5000	-	-	-	-	-	-	50

<sup>1</sup> Propagation delay from  $V_{DD}/2$  of internal signal to Pchannel/Nchannel on condition

<sup>2</sup> Slope at rising/falling edge

<sup>3</sup> Data based on characterization results, not tested in production

Table 34. Pad AC specifications (3.3 V, IPP\_HVE=0)<sup>1</sup>

Num	Pad	Tswitchon <sup>1</sup> (ns)			Rise/Fall <sup>2</sup> (ns)			Frequency (MHz)			Current slew <sup>3</sup> (mA/ns)			Load drive (pF)
		Min	Typ	Max	Min	Typ	Max	Min	Typ	Max	Min	Typ	Max	
1	Slow	3	-	40	4	-	40	-	-	4	0.01	-	2	25
		3	-	40	6	-	50	-	-	2	0.01	-	2	50
		3	-	40	10	-	75	-	-	2	0.01	-	2	100
		3	-	40	14	-	100	-	-	2	0.01	-	2	200
2	Medium	1	-	15	2	-	12	-	-	40	2.5	-	7	25
		1	-	15	4	-	25	-	-	20	2.5	-	7	50
		1	-	15	8	-	40	-	-	13	2.5	-	7	100
		1	-	15	14	-	70	-	-	7	2.5	-	7	200
3	Fast	1	-	6	1	-	4	-	-	72	3	-	40	25
		1	-	6	1.5	-	7	-	-	55	3	-	40	50
		1	-	6	3	-	12	-	-	40	3	-	40	100
		1	-	6	5	-	18	-	-	25	3	-	40	200
4	Symmetric	1	-	6	2	-	6	-	-	50	3	-	25	25
5	Pull Up/Down (3.6 V max)	-	-	-	-	-	7500	-	-	-	-	-	-	50

<sup>1</sup> Propagation delay from  $V_{DD}/2$  of internal signal to Pchannel/Nchannel on condition

<sup>2</sup> Slope at rising/falling edge

<sup>3</sup> Data based on characterization results, not tested in production

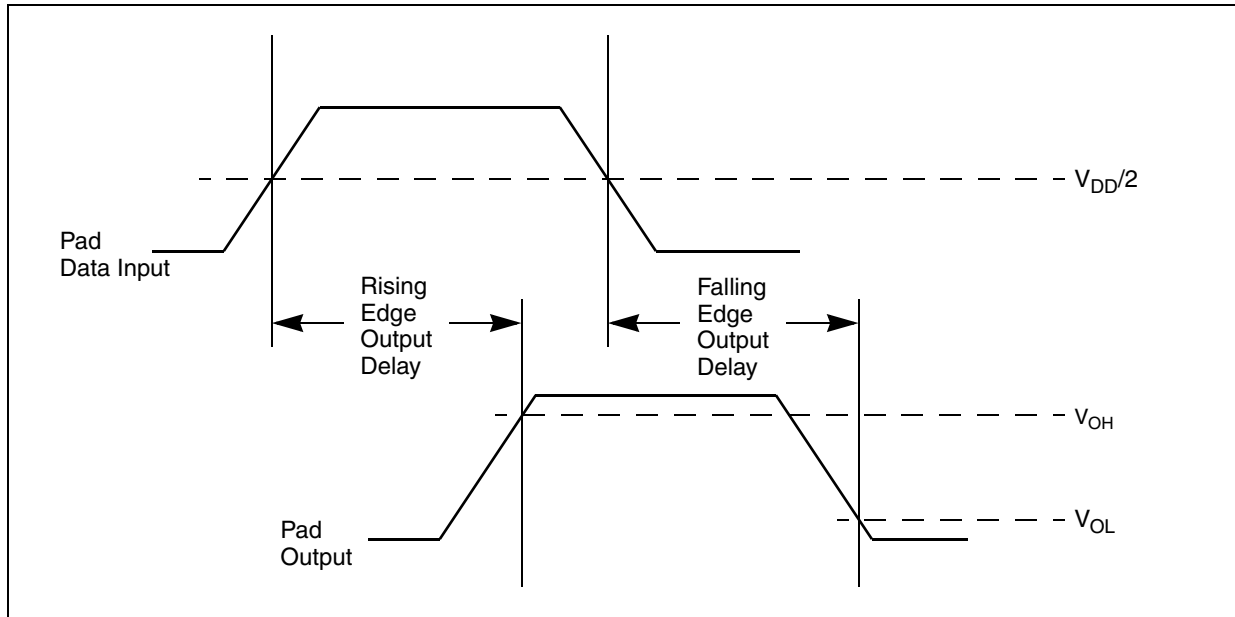

Figure 18. Pad Output Delay

### 3.16 AC Timing

#### 3.16.1 IEEE 1149.1 Interface Timing

Table 35. JTAG Interface Timing<sup>1</sup>

Num	Symbol	Characteristic	Min	Max	Unit
1	$t_{JCYC}$	CC <sup>2</sup> TCK Cycle Time	100	—	ns
2	$t_{JDC}$	CC <sup>2</sup> TCK Clock Pulse Width (Measured at $V_{DD}/2$ )	40	60	ns
3	$t_{TCKRISE}$	CC <sup>2</sup> TCK Rise and Fall Times (40% – 70%)	—	3	ns
4	$t_{TMSS}, t_{TDIS}$	CC <sup>2</sup> TMS, TDI Data Setup Time	5	—	ns
5	$t_{TMSH}, t_{TDIH}$	CC <sup>2</sup> TMS, TDI Data Hold Time	25	—	ns
6	$t_{TDOV}$	CC <sup>2</sup> TCK Low to TDO Data Valid	—	35	ns
7	$t_{TDOI}$	CC <sup>2</sup> TCK Low to TDO Data Invalid	0	—	ns
8	$t_{TDOHZ}$	CC <sup>2</sup> TCK Low to TDO High Impedance	—	30	ns
9	$t_{BSDV}$	CC <sup>2</sup> TCK Falling Edge to Output Valid	—	35	ns
10	$t_{BSDVZ}$	CC <sup>2</sup> TCK Falling Edge to Output Valid out of High Impedance	—	50	ns
11	$t_{BSDHZ}$	CC <sup>2</sup> TCK Falling Edge to Output High Impedance	—	50	ns
12	$t_{BSDST}$	CC <sup>2</sup> Boundary Scan Input Valid to TCK Rising Edge	50	—	ns
13	$t_{BSDHT}$	CC <sup>2</sup> TCK Rising Edge to Boundary Scan Input Invalid	50	—	ns

<sup>1</sup> These specifications apply to JTAG boundary scan only. JTAG timing specified at  $V_{DD} = 3.0\text{ V to }5.5\text{ V}$ ,  $T_A = -40\text{ to }105\text{ }^\circ\text{C}$ , and  $CL = 50\text{ pF}$  with  $SRC = 0b11$ .

<sup>2</sup> Parameter values guaranteed by design.

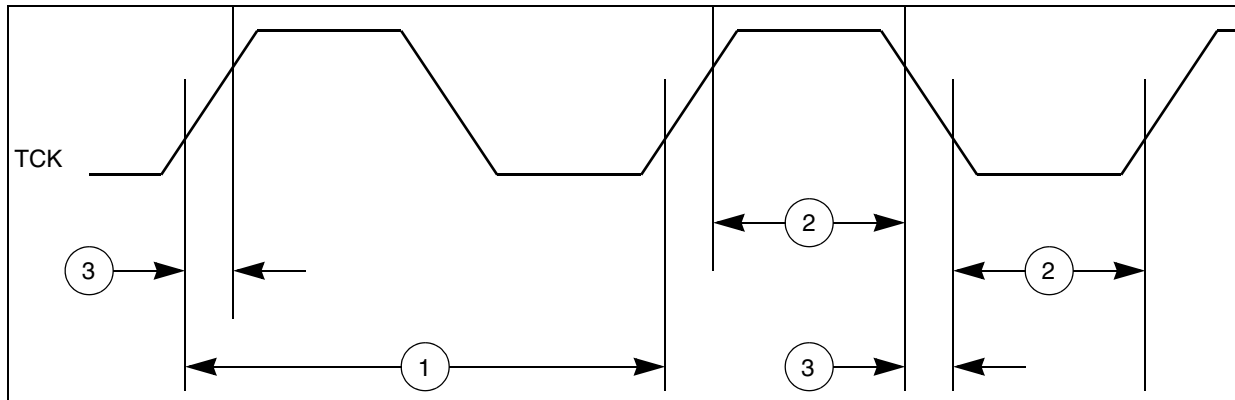

Figure 19. JTAG Test Clock Input Timing

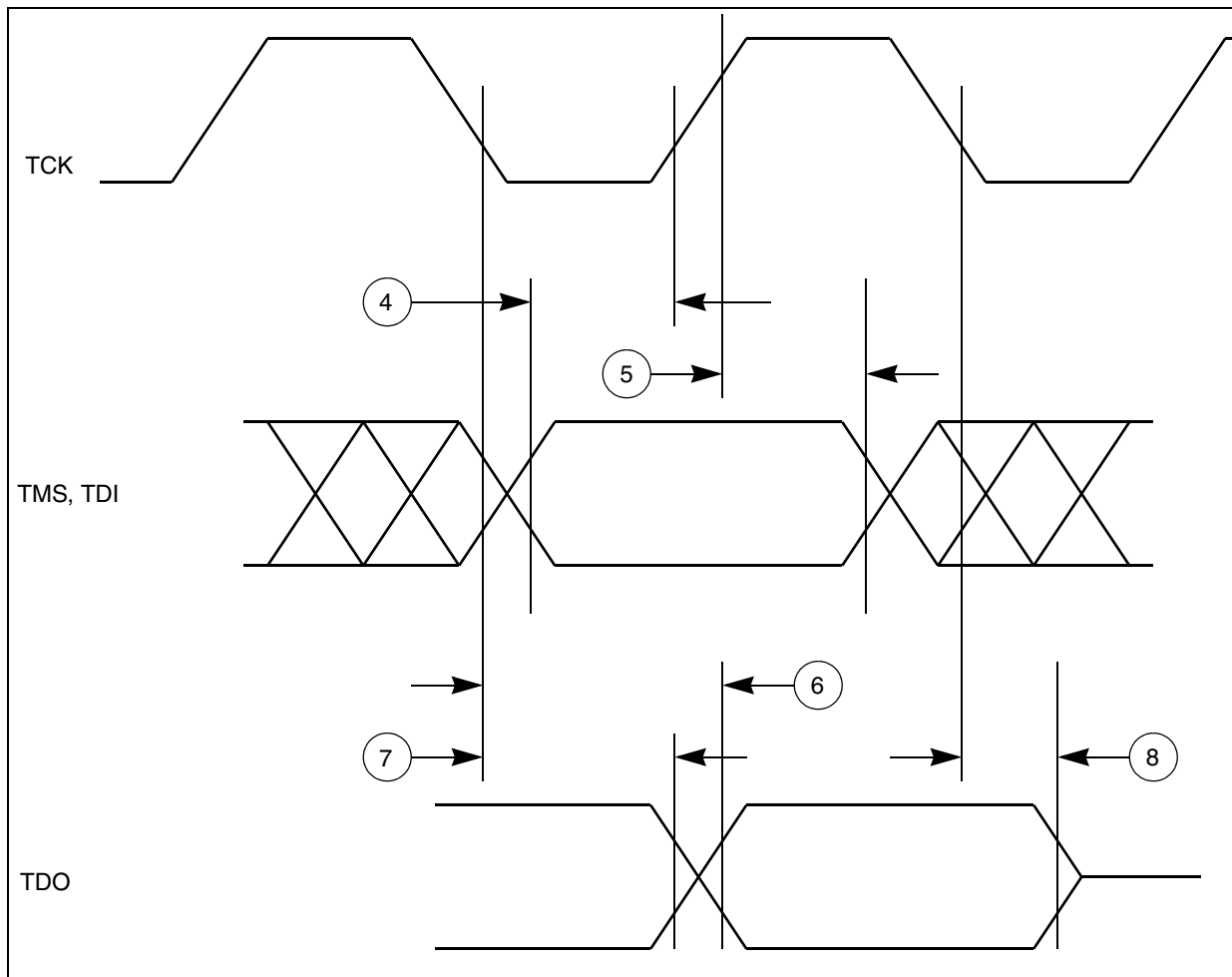

Figure 20. JTAG Test Access Port Timing

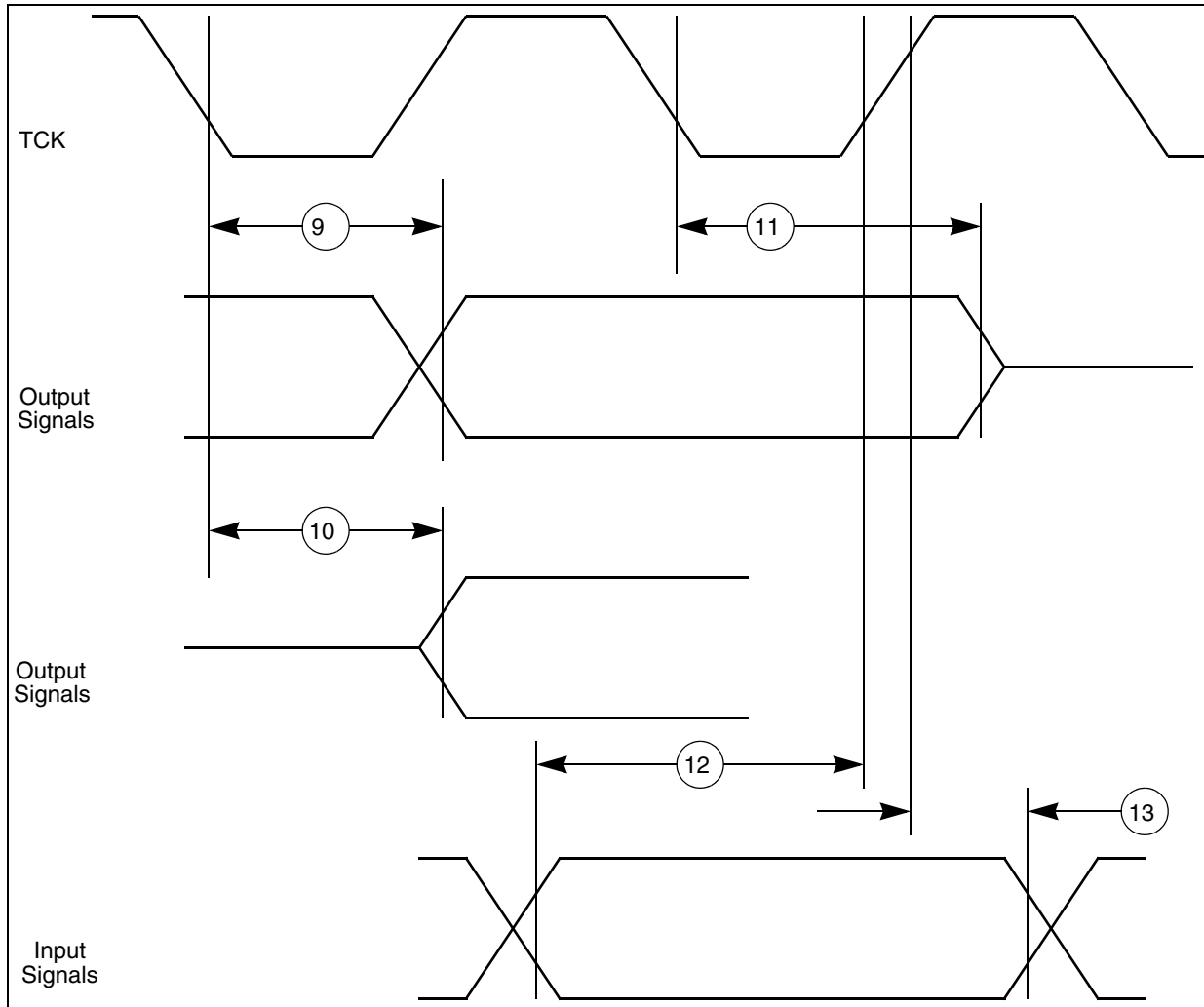

Figure 21. JTAG Boundary Scan Timing

### 3.16.2 Nexus Debug Interface

Table 36. Nexus Debug Port Timing<sup>1</sup>

Num	Symbol	Characteristic	Min	Max	Unit
1	$t_{MCCY}$	MCKO Cycle Time	22	—	ns
2	$t_{MDC}$	MCKO Duty Cycle	40	60	%
3	$t_{MDOV}$	MCKO Low to MDO Data Valid <sup>3</sup>	-2	14	ns
4	$t_{MSEOV}$	MCKO Low to $\overline{MSEO}$ Data Valid <sup>3</sup>	-2	14	ns
5	$t_{EVT OV}$	MCKO Low to $\overline{EVT O}$ Data Valid <sup>3</sup>	-2	14	ns
6	$t_{EVTIPW}$	$\overline{EVT I}$ Pulse Width	4	—	$t_{TCYC}$
7	$t_{EVTOPW}$	$\overline{EVT O}$ Pulse Width	1	—	$t_{MCCY}$
8	$t_{TCYC}$	TCK Cycle Time <sup>4</sup>	100	—	ns
9	$t_{TDC}$	TCK Duty Cycle	40	60	%
10	$t_{NTDIS}, t_{NTMSS}$	TDI, TMS Data Setup Time	25	—	ns
11	$t_{NTDIH}, t_{NTMSH}$	TDI, TMS Data Hold Time	5	—	ns
12	$t_{JOV}$	TCK Low to TDO Data Valid	0	35	ns

<sup>1</sup> JTAG specifications in this table apply when used for debug functionality. All Nexus timing relative to MCKO is measured from 50% of MCKO and 50% of the respective signal. Nexus timing specified at  $V_{DD} = 3.0\text{ V to }5.5\text{ V}$ ,  $T_A = -40\text{ to }105\text{ }^\circ\text{C}$ , and  $CL = 50\text{ pF}$  ( $CL=30\text{ pF}$  on MCKO), with  $SRC = 0b11$ .

<sup>2</sup> Parameter values guaranteed by design.

<sup>3</sup> MDO,  $\overline{MSEO}$ , and  $\overline{EVT O}$  data is held valid until next MCKO low cycle.

<sup>4</sup> The system clock frequency needs to be three times faster than the TCK frequency.

Figure 22. Nexus Clock Timing

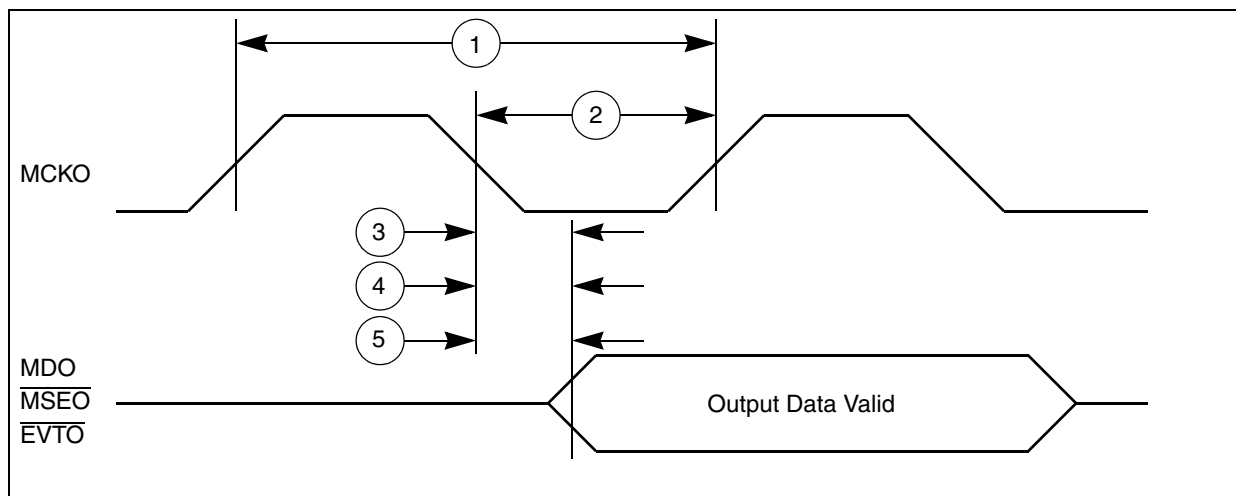

Figure 23. Nexus Output Timing

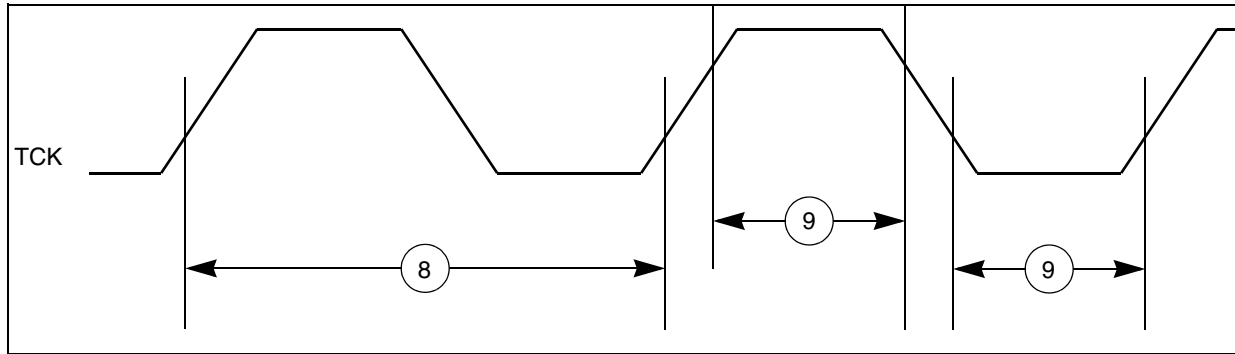

Figure 24. Nexus TCK Timing

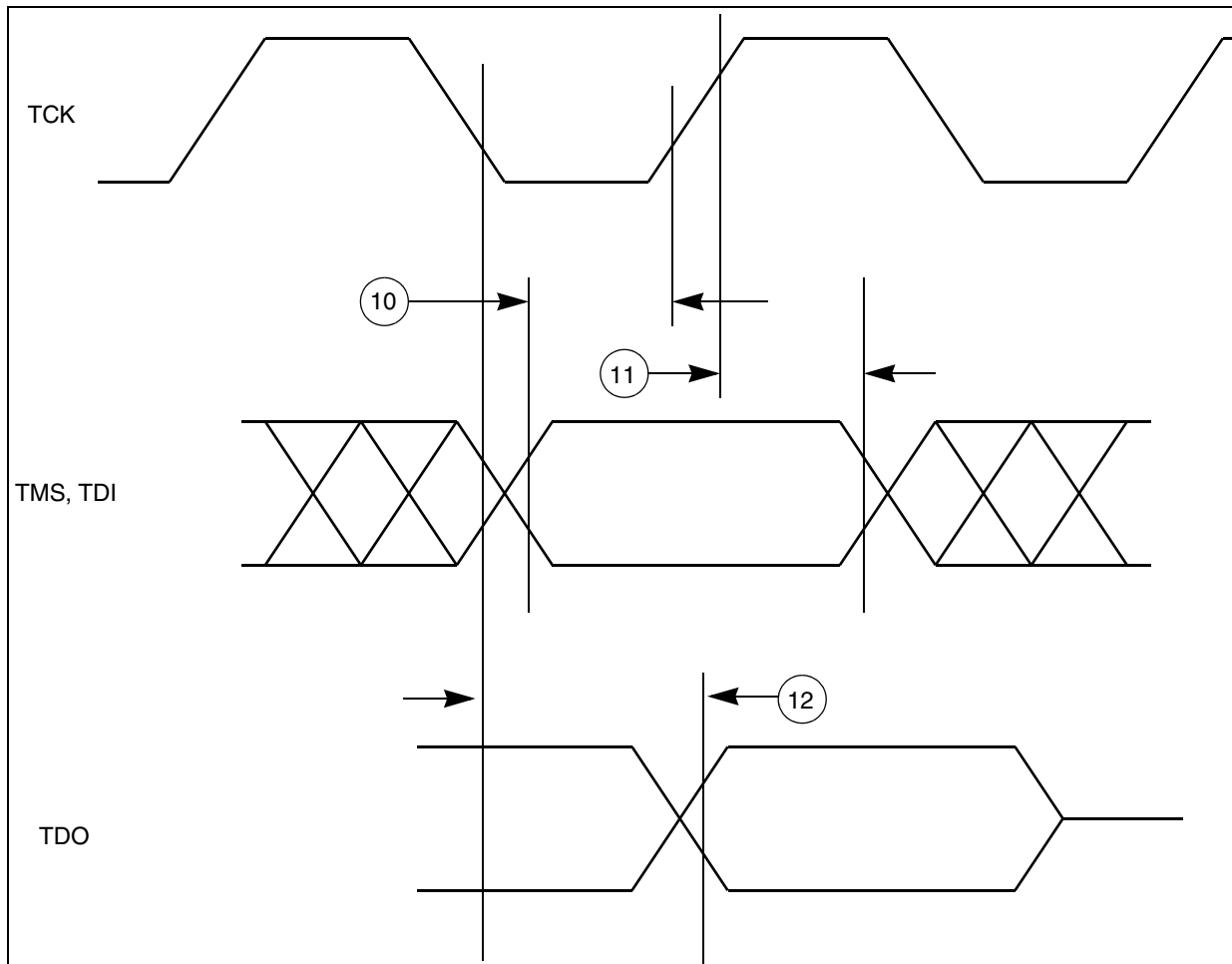

Figure 25. Nexus TDI, TMS, TDO Timing

### 3.16.3 Interface to TFT LCD Panels

Figure 26 depicts the LCD interface timing for a generic active matrix color TFT panel. In this figure signals are shown with positive polarity. The sequence of events for active matrix interface timing is:

- DCU\_CLK latches data into the panel on its positive edge (when positive polarity is selected). In active mode, DCU\_CLK runs continuously. This signal frequency could be from 5 to 66 MHz depending on the panel type.

- DCU\_HSYNC causes the panel to start a new line. It always encompasses at least one PCLK pulse.
- DCU\_VSYNC causes the panel to start a new frame. It always encompasses at least one HSYNC pulse.
- DCU\_DE acts like an output enable signal to the LCD panel. This output enables the data to be shifted onto the display. When disabled, the data is invalid and the trace is off.

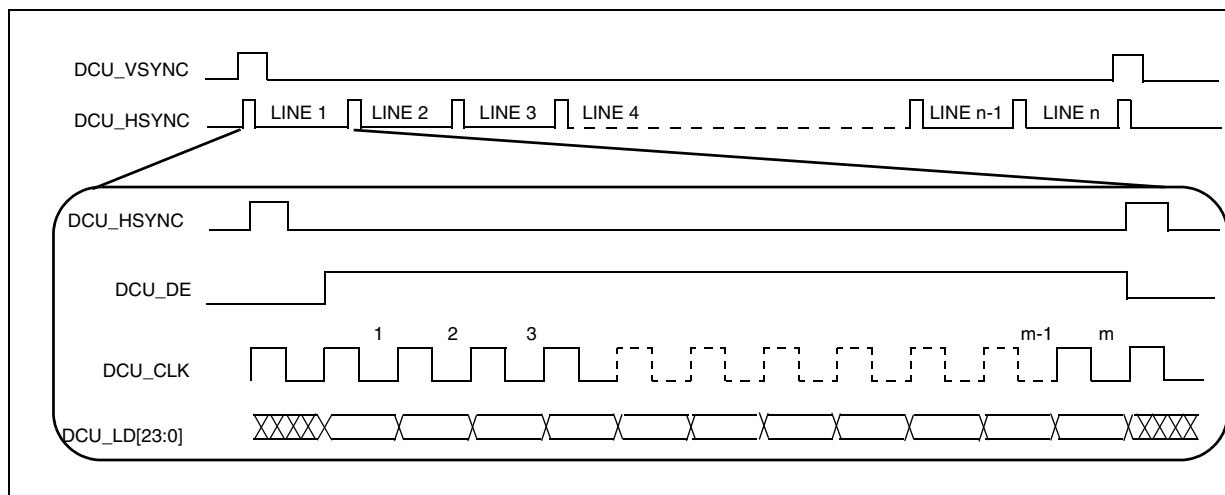

Figure 26. TFT LCD Interface Timing Overview<sup>1</sup>

### 3.16.3.1 Interface to TFT LCD Panels—Pixel Level Timings

Figure 27 depicts the horizontal timing (timing of one line), including both the horizontal sync pulse and data. All parameters shown in the diagram are programmable. This timing diagram corresponds to positive polarity of the DCU\_CLK signal (meaning the data and sync signals change on the rising edge) and active-high polarity of the DCU\_HSYNC, DCU\_VSYNC and DCU\_DE signals. The user can select the polarity of the DCU\_HSYNC and DCU\_VSYNC signals via the SYN\_POL register, whether active-high or active-low. The default is active-high. The DCU\_DE signal is always active-high.

Pixel clock inversion and a flexible programmable pixel clock delay are also supported. They are programmed via the DCU Clock Confide Register (DCCR) in the system clock module.

The DELTA\_X and DELTA\_Y parameters are programmed via the DISP\_SIZE register. The PW\_H, BP\_H and FP\_H parameters are programmed via the HSYN PARA register. The PW\_V, BP\_V and FP\_V parameters are programmed via the VSYN\_PARA register.

Table 37. LCD Interface Timing Parameters—Horizontal and Vertical

Num	Symbol	Characteristic	Value	Unit
1	$t_{PCP}$	CC <sup>1</sup> Display pixel clock period	31.25	ns
2	$t_{PWH}$	CC <sup>1</sup> HSYNC pulse width	$PW_H * t_{PCP}$	ns
3	$t_{BPH}$	CC <sup>1</sup> HSYNC back porch width	$BP_H * t_{PCP}$	ns
4	$t_{FPH}$	CC <sup>1</sup> HSYNC front porch width	$FP_H * t_{PCP}$	ns
5	$t_{SW}$	CC <sup>1</sup> Screen width	$DELTA_X * t_{PCP}$	ns

1. In Figure 26, the “DCU\_LD[23:0]” signal is an aggregation of the DCU’s RGB signals—DCU\_R[0:7], DCU\_G[0:7] and DCU\_B[0:7].

**Table 37. LCD Interface Timing Parameters—Horizontal and Vertical (continued)**

Num	Symbol	Characteristic	Value	Unit
6	$t_{HSP}$	CC <sup>1</sup> HSYNC (line) period	$(PW\_H + BP\_H + FP\_H + DELTA\_X) * t_{PCP}$	ns
7	$t_{PWV}$	CC <sup>1</sup> VSYNC pulse width	$PWV * t_{HSP}$	ns
8	$t_{BPV}$	CC <sup>1</sup> VSYNC back porch width	$BP\_V * t_{HSP}$	ns
	$t_{FPV}$	CC <sup>1</sup> VSYNC front porch width	$FP\_V * t_{HSP}$	ns
	$t_{SH}$	CC <sup>1</sup> Screen height	$DELTA\_Y * t_{HSP}$	ns
	$t_{VSP}$	CC <sup>1</sup> VSYNC (frame) period	$(PW\_V + BP\_V + FP\_V + DELTA\_Y) * t_{HSP}$	ns

<sup>1</sup> Parameter values guaranteed by design.

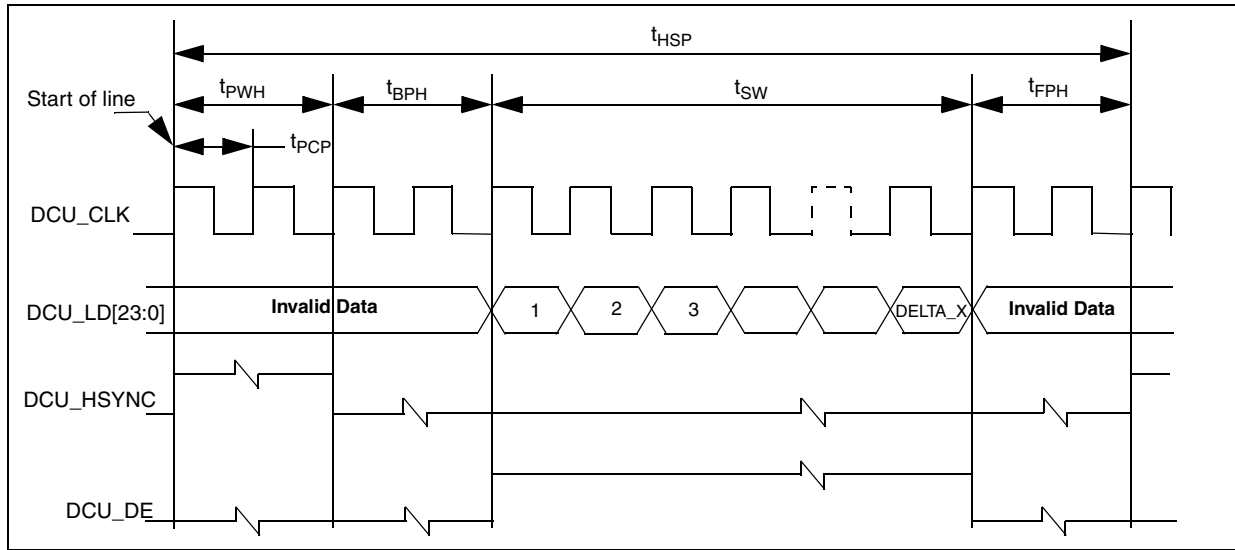

**Figure 27. Horizontal Sync Timing**

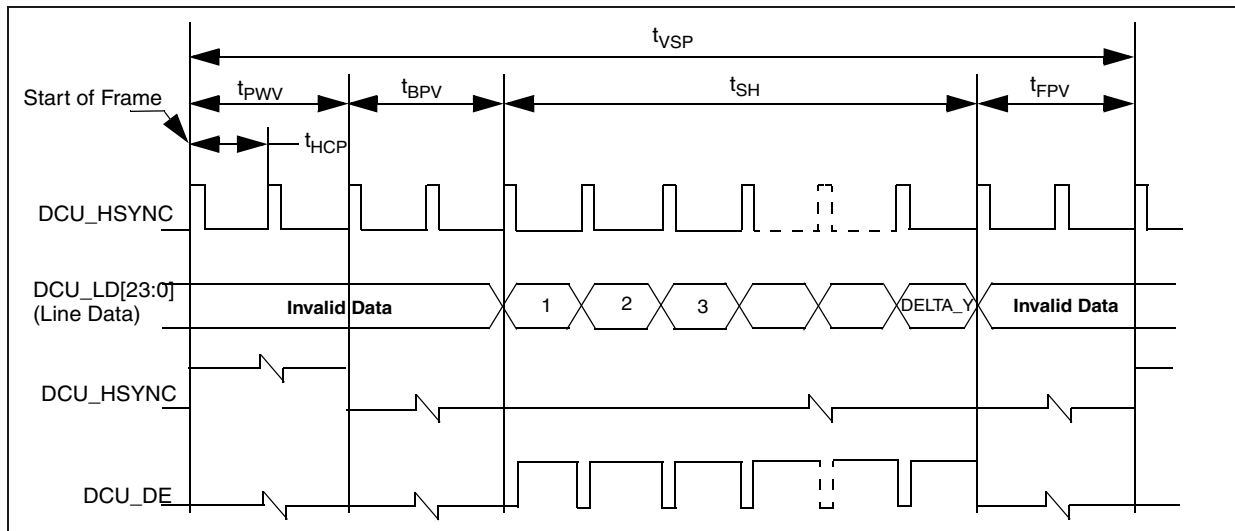

**Figure 28. Vertical Sync Pulse**



### 3.16.3.2 Interface to TFT LCD Panels—Access Level

Table 38. LCD Interface Timing Parameters<sup>1,2,3,4</sup>—Access Level

Num	Symbol	Characteristic	Min. Value	Typical Value	Max. Value	Unit
1	$t_{CKP}$	CC <sup>5</sup> PDI Clock Period	31.25	—		ns
2	$t_{CHD}$	CC <sup>5</sup> Duty cycle	40	—	60	%
3	$t_{DSU}$	CC <sup>5</sup> interface data setup time	6	—		ns
4	$t_{DHD}$	CC <sup>5</sup> PDI interface data access hold time	1	—		ns
5	$t_{CSU}$	CC <sup>5</sup> PDI interface control signal setup time	3	—		ns
6	$t_{CHD}$	CC <sup>5</sup> PDI interface control signal hold time	1	—		ns
7		CC <sup>5</sup> TFT interface data valid after pixel clock		—	6	ns
8		CC <sup>5</sup> TFT interface HSYNC valid after pixel clock		—	5	ns
9		CC <sup>5</sup> TFT interface VSYNC valid after pixel clock		—	5.5	ns
10		CC <sup>5</sup> TFT interface DE valid after pixel clock		—	5.6	ns
11		CC <sup>5</sup> TFT interface hold time for data and control bits	2	—		ns
12		CC <sup>5</sup> Relative skew between the data bits		—	3.7	ns

<sup>1</sup> The characteristics in this table are based on the assumption that data is output at +ve edge and displays latch data on -ve edge

<sup>2</sup> Intra bit skew is less than 2 ns

<sup>3</sup> Load CL = 50 pF for frequency up to 20 MHz

<sup>4</sup> Load CL = 25 pF for display freq from 20 to 32 MHz

<sup>5</sup> Parameter values guaranteed by design.

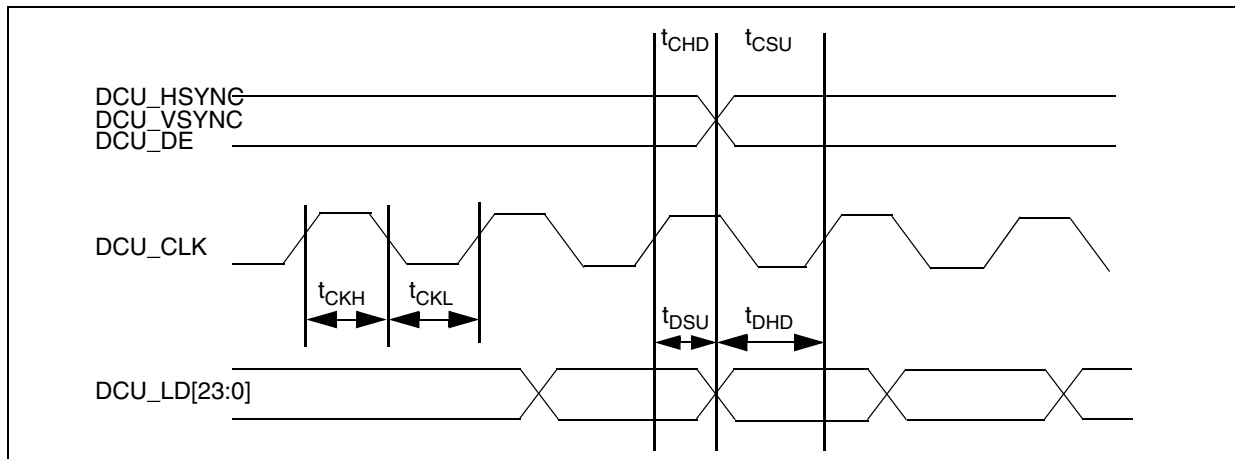

Figure 29. LCD Interface Timing Parameters—Access Level

### 3.16.4 External Interrupt (IRQ) and Non-Maskable Interrupt (NMI) Timing

Table 39. IRQ and NMI Timing

Num	Symbol	Characteristic	Min. Value	Max. Value	Unit
1	$t_{IPWL}$ CC <sup>1</sup>	IRQ/NMI Pulse Width Low	200	—	ns
2	$t_{IPWH}$ CC <sup>1</sup>	IRQ/NMI Pulse Width High	200	—	ns
3	$t_{ICYC}$ CC <sup>1</sup>	IRQ/NMI Edge to Edge Time <sup>2</sup>	400	—	ns

<sup>1</sup> Parameter values guaranteed by design.

<sup>2</sup> Applies when IRQ/NMI pins are configured for rising edge or falling edge events, but not both.

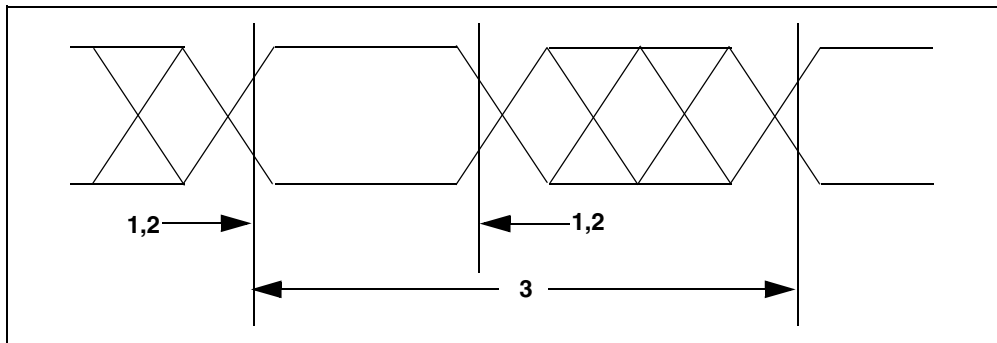

Figure 30. IRQ and NMI Timing

### 3.16.5 Enhanced Modular I/O Subsystem (eMIOS) Timing

Table 40. eMIOS Timing<sup>1</sup>

Num	Symbol	Characteristic	Min. Value <sup>2</sup>	Max. Value	Unit
1	$t_{MIPW}$ CC <sup>3</sup>	eMIOS Input Pulse Width	4	—	$t_{CYC}$
2	$t_{MOPW}$ CC <sup>3</sup>	eMIOS Output Pulse Width	1	—	$t_{CYC}$

<sup>1</sup> eMIOS timing specified at  $f_{SYS} = 64$  MHz,  $V_{DD12} = 1.14$  V to 1.32 V,  $V_{DDE\_x} = 3.0$  V to 5.5 V,  $T_A = -40$  to 105 °C, and  $CL = 50$  pF with SRC = 0b00

<sup>2</sup> There is no limitation on the peripheral for setting the minimum pulse width, the actual width is restricted by the pad delays. Refer to the pad specification section for the details.

<sup>3</sup> Parameter values guaranteed by design.

### 3.16.6 FlexCAN Timing

The CAN functions are available as TX pins at normal IO pads and as RX pins at the always on domain. There is no filter for the wakeup dominant pulse. Any high-to-low edge can cause wakeup if configured.

Table 41. FlexCAN Timing<sup>1</sup>

Num	Symbol	Characteristic	Min. Value	Max. Value	Unit
1	$t_{CANOV}$ CC <sup>2</sup>	CTNX Output Valid after CLKOUT Rising Edge (Output Delay)	—	22.48	ns
2	$t_{CANSU}$ CC <sup>2</sup>	CNRX Input Valid to CLKOUT Rising Edge (Setup Time)	—	12.46	ns

<sup>1</sup> FlexCAN timing specified at  $f_{SYS} = 64$  MHz,  $V_{DD12} = 1.14$  V to 1.32 V,  $VDDE\_x = 3.0$  V to 5.5 V,  $T_A = -40$  to 105 °C, and  $CL = 50$  pF with  $SRC = 0b00$ .

<sup>2</sup> Parameter values guaranteed by design.

### 3.16.7 Deserial Serial Peripheral Interface (DSPI)

Table 42. DSPI Timing<sup>1</sup>

Num	Symbol	Characteristic	Min	Max	Unit
1	$t_{SCK}$	CC <sup>2</sup> SCK Cycle Time <sup>3,4</sup>	60	—	ns
2	$t_{CSC}$	CC <sup>2</sup> PCS to SCK Delay <sup>5</sup>	-	—	ns
3	$t_{ASC}$	CC <sup>2</sup> After SCK Delay <sup>6</sup>	20	—	ns
4	$t_{SDC}$	CC <sup>2</sup> SCK Duty Cycle	$t_{SCK}/2$ -2ns	$t_{SCK}/2$ + 2ns	ns
5	$t_A$	CC <sup>2</sup> Slave Access Time (PCs active to SOUT driven)	—	25	ns
6	$t_{DIS}$	CC <sup>2</sup> Slave SOUT Disable Time (PCs inactive to SOUT High-Z or invalid)	—	25	ns
7	$t_{SUI}$	CC <sup>2</sup> Data Setup Time for Inputs Master (MTFE = 0) Slave Master (MTFE = 1, CPHA = 0) <sup>7</sup> Master (MTFE = 1, CPHA = 1)	35 5 5 35	— — — —	ns ns ns ns
8	$t_{HI}$	CC <sup>2</sup> Data Hold Time for Inputs Master (MTFE = 0) Slave Master (MTFE = 1, CPHA = 0) <sup>7</sup> Master (MTFE = 1, CPHA = 1)	-4 10 26 -4	— — — —	ns ns ns ns
9	$t_{SUO}$	CC <sup>2</sup> Data Valid (after SCK edge) Master (MTFE = 0) Slave Master (MTFE = 1, CPHA=0) Master (MTFE = 1, CPHA=1)	— — — —	15 35 30 15	ns ns ns ns
10	$t_{HO}$	CC <sup>2</sup> Data Hold Time for Outputs Master (MTFE = 0) Slave Master (MTFE = 1, CPHA = 0) Master (MTFE = 1, CPHA = 1)	-15 5.5 0 -15	— — — —	ns ns ns ns

<sup>1</sup> DSPI timing specified at  $VDDE\_x = 3.0$  V to 5.5V,  $T_A = -40$  to 105 °C, and  $CL = 50$  pF with  $SRC = 0b11$ .

<sup>2</sup> Parameter values guaranteed by design.

<sup>3</sup> The minimum SCK Cycle Time restricts the baud rate selection for given system clock rate.

<sup>4</sup> The actual minimum SCK Cycle Time is limited by pad performance.

<sup>5</sup> The maximum value is programmable in  $DSPI\_CTARx[PSSCK]$  and  $DSPI\_CTARx[CSSCK]$ , program  $PSSCK=2$  &  $CSSCK = 2$

<sup>6</sup> The maximum value is programmable in  $DSPI\_CTARx[PASC]$  and  $DSPI\_CTARx[ASC]$

<sup>7</sup> This delay value is corresponding to  $SMPL\_PT=00b$  which is bit field 9 and 8 of  $DSPI\_MCR$  register.

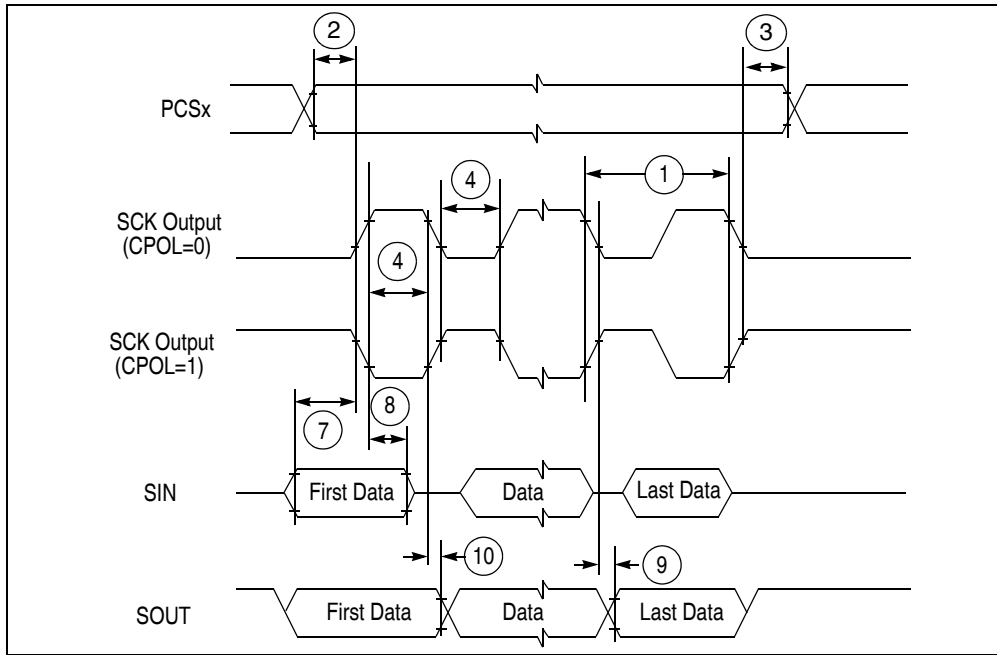

Figure 31. DSPI Classic SPI Timing — Master, CPHA = 0

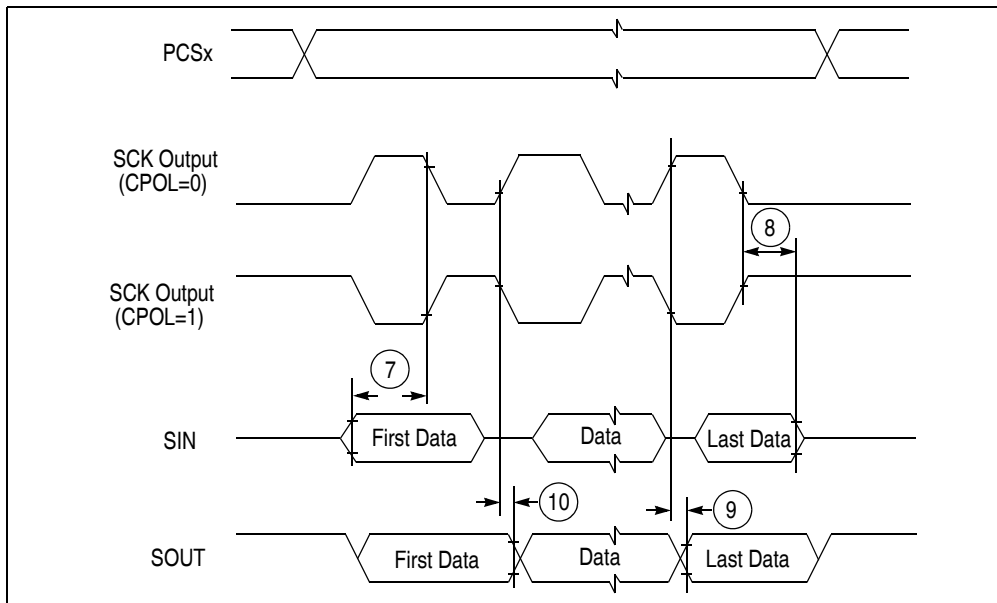

Figure 32. DSPI Classic SPI Timing — Master, CPHA = 1

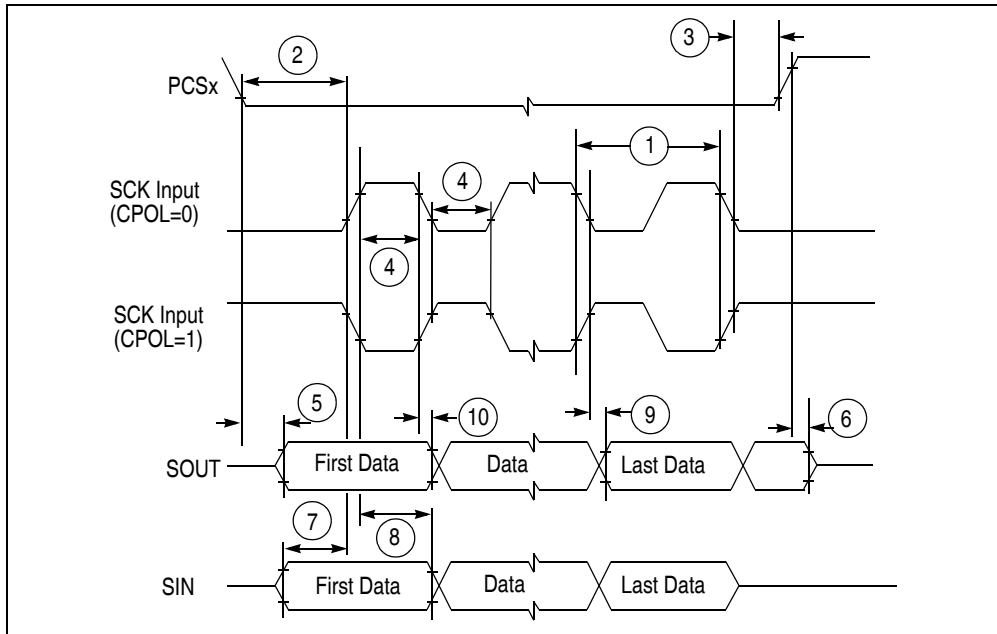

Figure 33. DSPI Classic SPI Timing — Slave, CPHA = 0

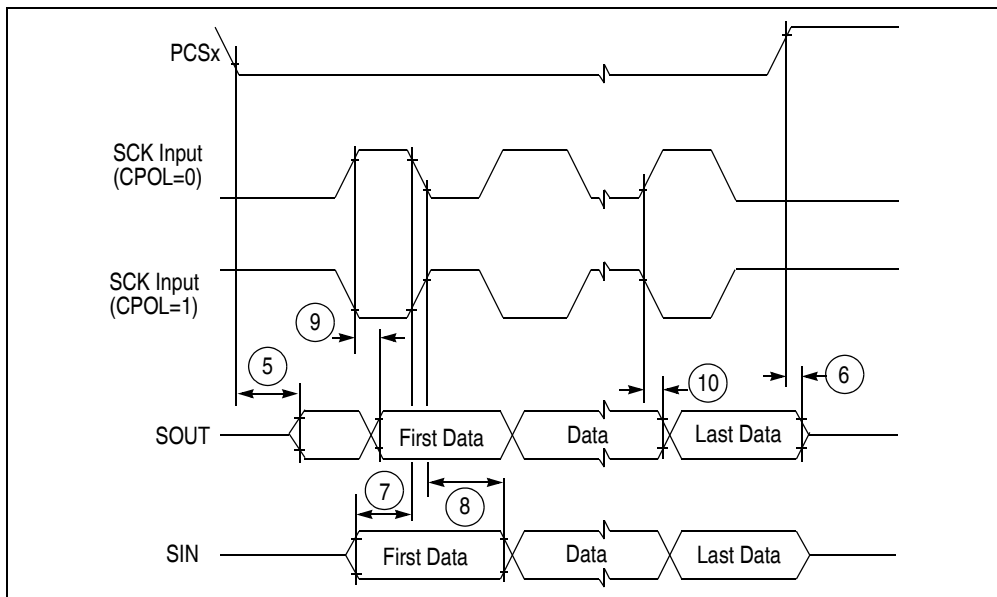

Figure 34. DSPI Classic SPI Timing — Slave, CPHA = 1

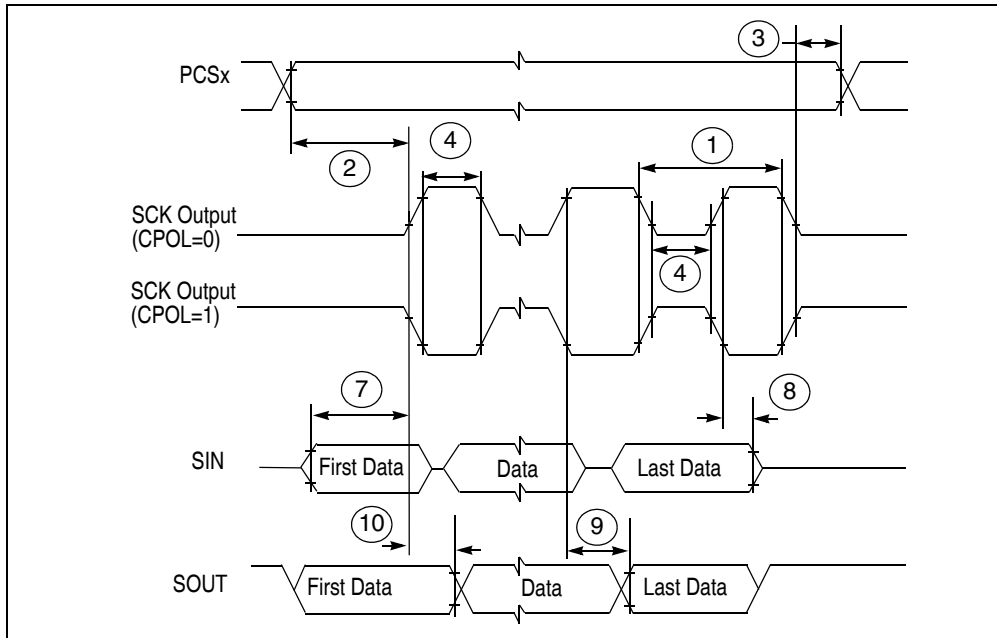

Figure 35. DSPI Modified Transfer Format Timing — Master, CPHA = 0

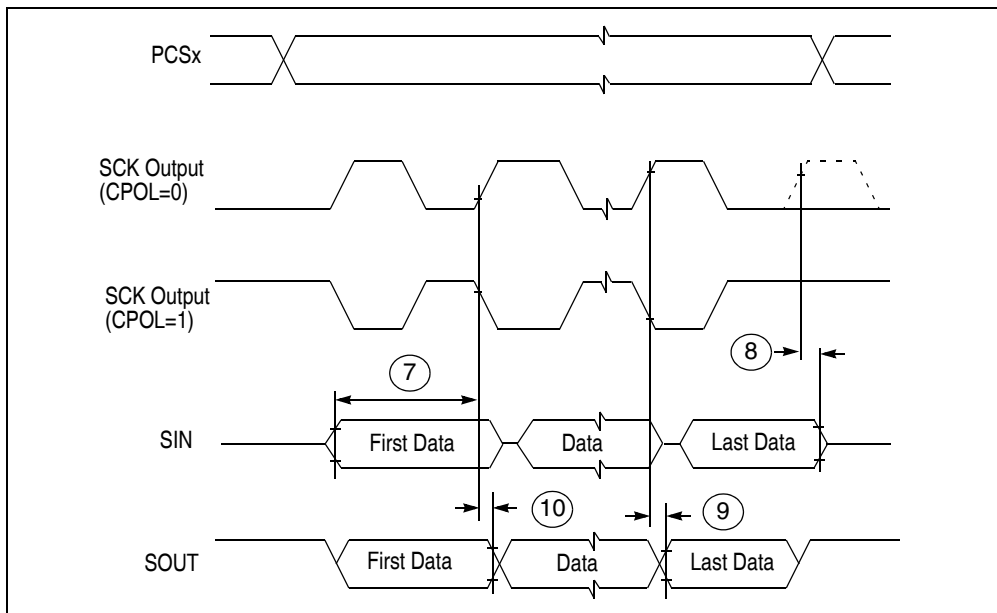

Figure 36. DSPI Modified Transfer Format Timing — Master, CPHA = 1

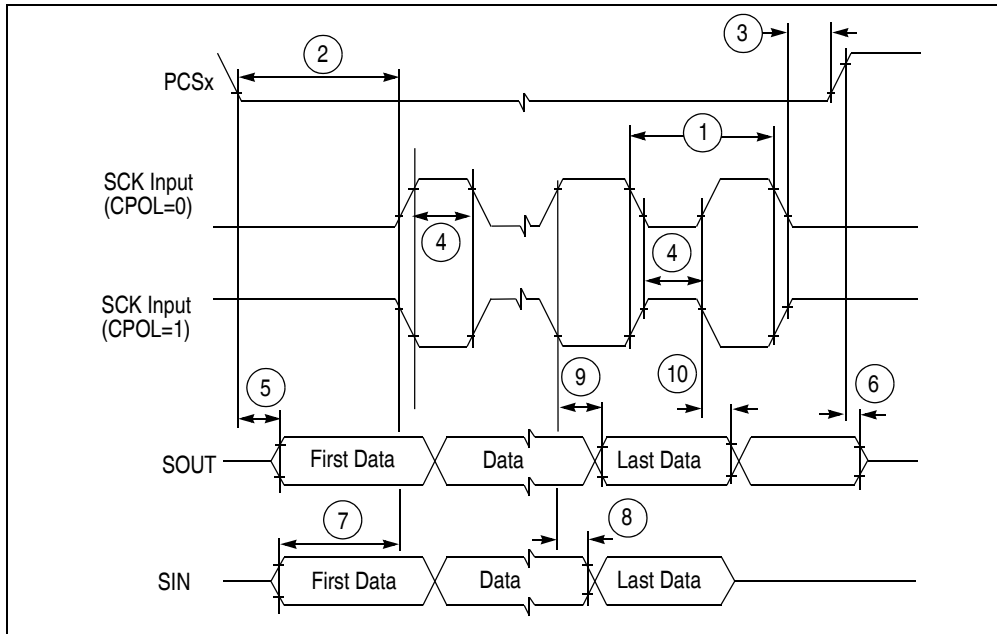

Figure 37. DSPI Modified Transfer Format Timing — Slave, CPHA = 0

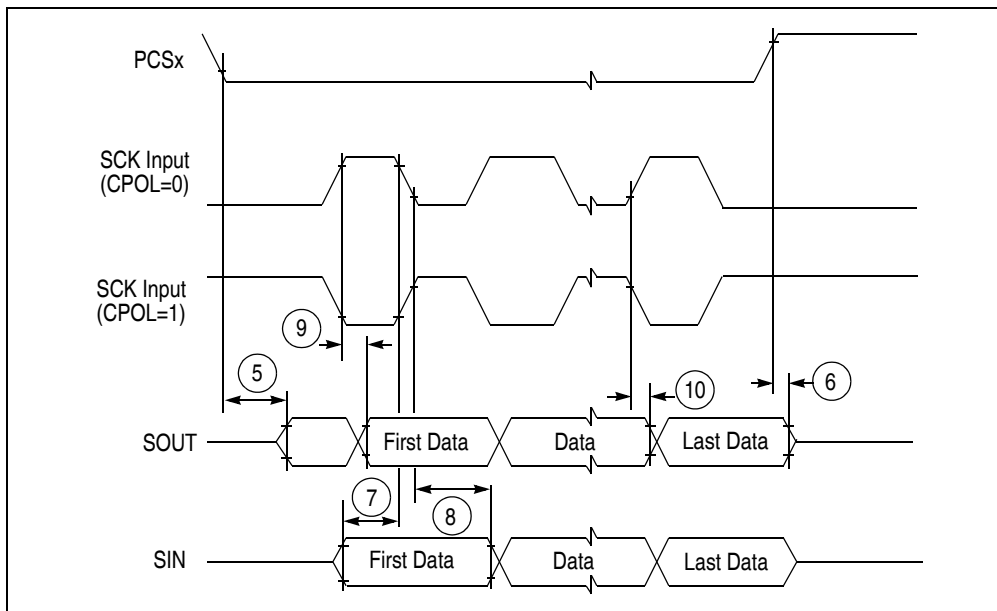

Figure 38. DSPI Modified Transfer Format Timing — Slave, CPHA = 1

3.16.8 I<sup>2</sup>C TimingTable 43. I<sup>2</sup>C Input Timing Specifications—SCL and SDA

Num	Symbol		Characteristic	Min. Value	Max. Value	Unit
1	—	CC <sup>1</sup>	Start condition hold time	2	—	IP-Bus Cycle <sup>2</sup>
2	—	CC <sup>1</sup>	Clock low time	8	—	IP-Bus Cycle <sup>2</sup>
4	—	CC <sup>1</sup>	Data hold time	0.0	—	ns
6	—	CC <sup>1</sup>	Clock high time	4	—	IP-Bus Cycle <sup>2</sup>
7	—	CC <sup>1</sup>	Data setup time	0.0	—	ns
8	—	CC <sup>1</sup>	Start condition setup time (for repeated start condition only)	2	—	IP-Bus Cycle <sup>2</sup>
9	—	CC <sup>1</sup>	Stop condition setup time	2	—	IP-Bus Cycle <sup>2</sup>

<sup>1</sup> Parameter values guaranteed by design.

<sup>2</sup> Inter Peripheral Clock is the clock at which the I<sup>2</sup>C peripheral is working in the device

Table 44. I<sup>2</sup>C Output Timing Specifications—SCL and SDA

Num	Symbol		Characteristic	Min. Value	Max. Value	Unit
1 <sup>1</sup>	—	CC <sup>2</sup>	Start condition hold time	6	—	IP-Bus Cycle <sup>3</sup>
2 <sup>1</sup>	—	CC <sup>2</sup>	Clock low time	10	—	IP-Bus Cycle <sup>2</sup>
3 <sup>4</sup>	—	CC <sup>2</sup>	SCL/SDA rise time	—	99.6	ns
4 <sup>1</sup>	—	CC <sup>2</sup>	Data hold time	7	—	IP-Bus Cycle <sup>2</sup>
5 <sup>1</sup>	—	CC <sup>2</sup>	SCL/SDA fall time	—	99.5	ns
6 <sup>1</sup>	—	CC <sup>2</sup>	Clock high time	10	—	IP-Bus Cycle <sup>2</sup>
7 <sup>1</sup>	—	CC <sup>2</sup>	Data setup time	2	—	IP-Bus Cycle <sup>2</sup>
8 <sup>1</sup>	—	CC <sup>2</sup>	Start condition setup time (for repeated start condition only)	20	—	IP-Bus Cycle <sup>2</sup>
9 <sup>1</sup>	—	CC <sup>2</sup>	Stop condition setup time	10	—	IP-Bus Cycle <sup>2</sup>

<sup>1</sup> Programming IBFD (I<sup>2</sup>C bus Frequency Divider) with the maximum frequency results in the minimum output timings listed. The I<sup>2</sup>C interface is designed to scale the data transition time, moving it to the middle of the SCL low period. The actual position is affected by the prescale and division values programmed in IFDR.

<sup>2</sup> Parameter values guaranteed by design.

<sup>3</sup> Inter Peripheral Clock is the clock at which the I<sup>2</sup>C peripheral is working in the device

<sup>4</sup> Because SCL and SDA are open-drain-type outputs, which the processor can only actively drive low, the time SCL or SDA takes to reach a high level depends on external signal capacitance and pull-up resistor values.

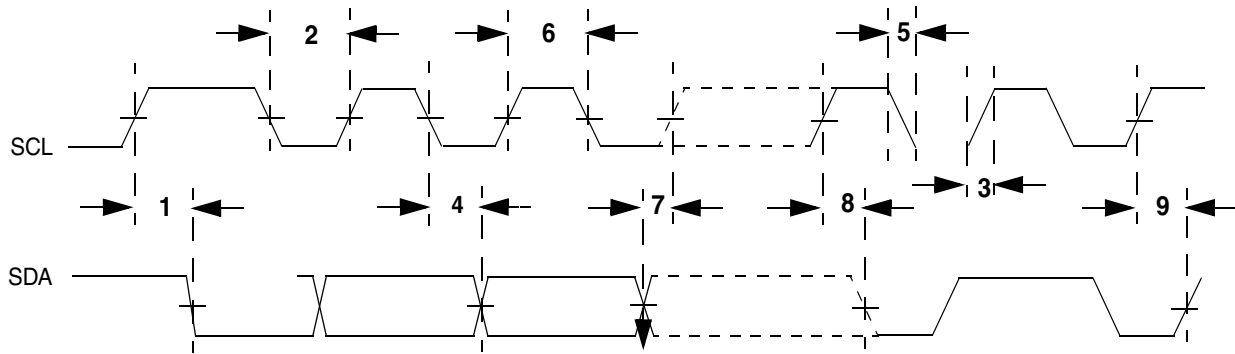

Figure 39. I<sup>2</sup>C Input/Output Timing

### 3.16.9 Mechanical Outline Drawings

### 3.17 144 LQFP

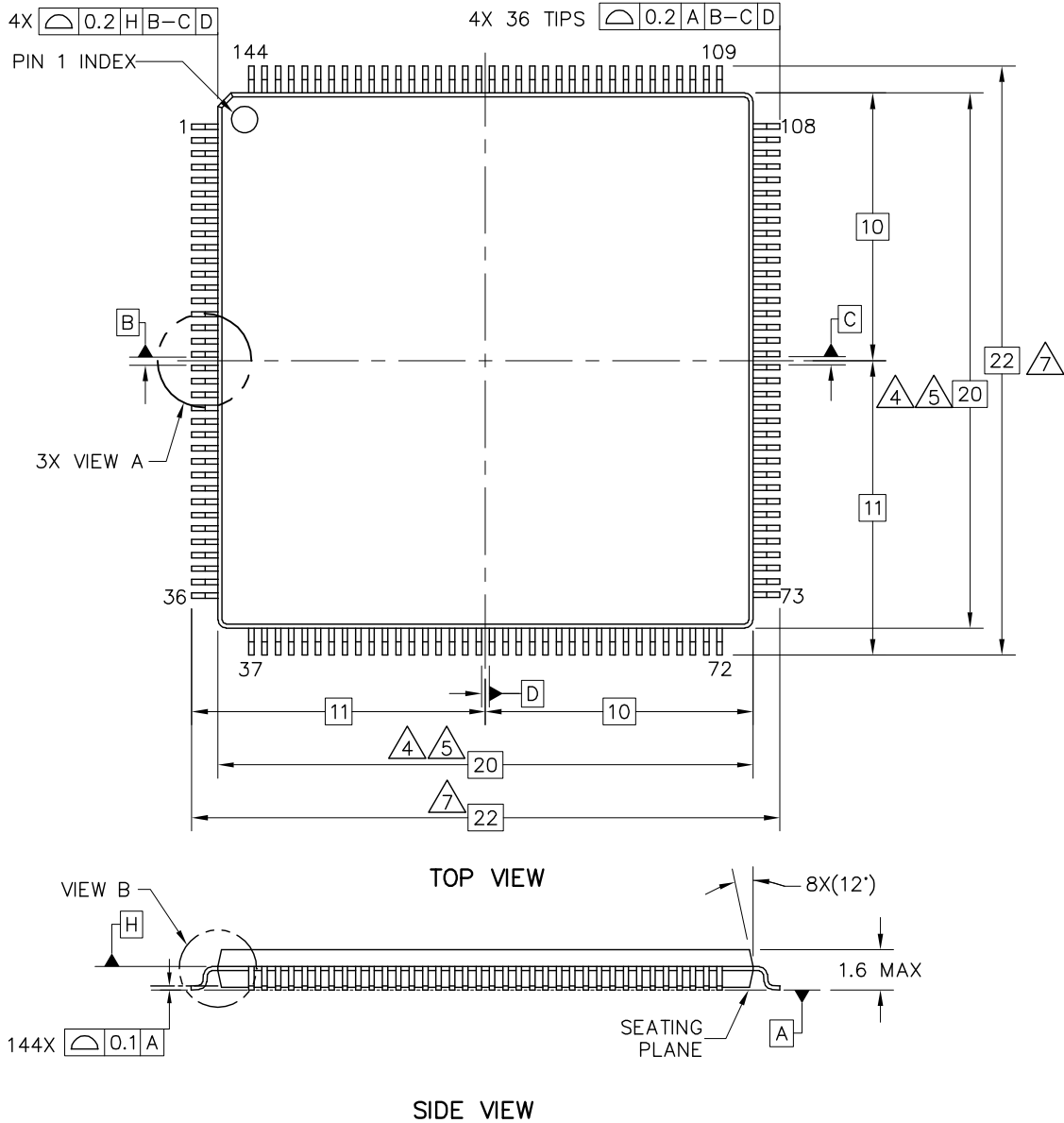

© FREESCALE SEMICONDUCTOR, INC. ALL RIGHTS RESERVED.	<b>MECHANICAL OUTLINE</b>	PRINT VERSION NOT TO SCALE	
TITLE: 144 LEAD LQFP 20 X 20, 0.5 PITCH, 1.4 THICK	DOCUMENT NO: 98ASS23177W	REV: F	
	CASE NUMBER: 918-03	20 MAY 2005	
	STANDARD: NON-JEDEC		

Figure 40. LQFP144 Mechanical Drawing (Part 1 of 3)

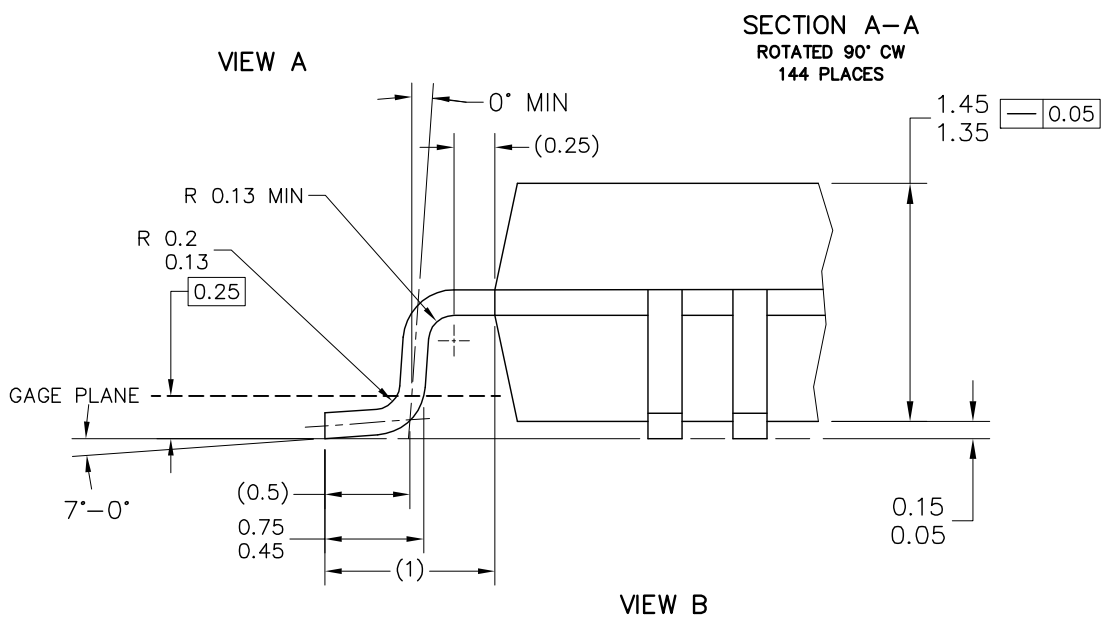
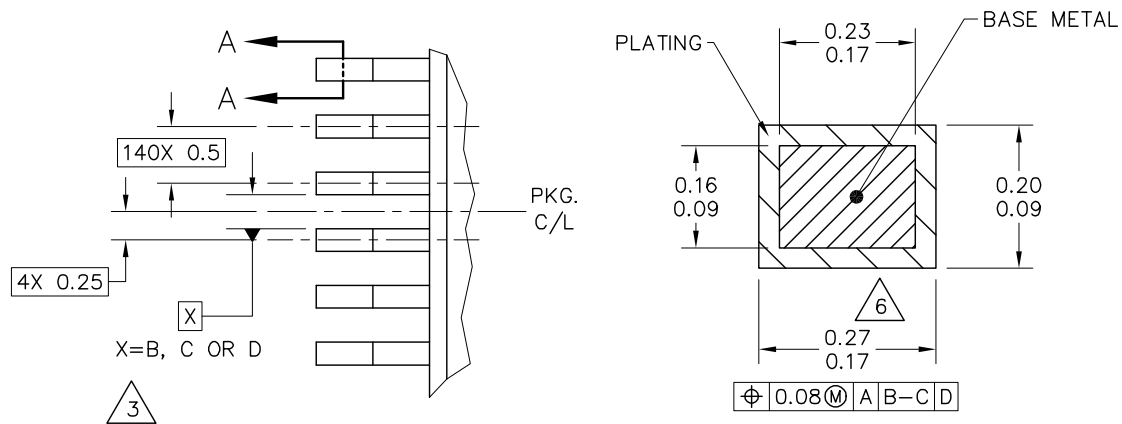

© FREESCALE SEMICONDUCTOR, INC. ALL RIGHTS RESERVED.	<b>MECHANICAL OUTLINE</b>	PRINT VERSION NOT TO SCALE
TITLE: 144 LEAD LQFP 20 X 20, 0.5 PITCH, 1.4 THICK	DOCUMENT NO: 98ASS23177W	REV: F
	CASE NUMBER: 918-03	20 MAY 2005
	STANDARD: NON-JEDEC	

Figure 41. LQFP144 Mechanical Drawing (Part 2 of 3)

## Electrical Characteristics

### NOTES:

1. ALL DIMENSIONS ARE IN MILLIMETERS.
2. INTERPRET DIMENSIONS AND TOLERANCES PER ASME Y14.5M-1994.
3. DATUMS B, C AND D TO BE DETERMINED AT DATUM PLANE H.
4. THE TOP PACKAGE BODY SIZE MAY BE SMALLER THAN THE BOTTOM PACKAGE SIZE BY A MAXIMUM OF 0.1 mm.
5. THIS DIMENSIONS DO NOT INCLUDE MOLD PROTRUSIONS. THE MAXIMUM ALLOWABLE PROTRUSION IS 0.25 mm PER SIDE. THIS DIMENSIONS ARE MAXIMUM BODY SIZE DIMENSIONS INCLUDING MOLD MISMATCH.
6. THIS DIMENSION DOES NOT INCLUDE DAM BAR PROTRUSION. PROTRUSIONS SHALL NOT CAUSE THE LEAD WIDTH TO EXCEED 0.35. MINIMUM SPACE BETWEEN PROTRUSION AND AN ADJACENT LEAD SHALL BE 0.07 MM.
7. THIS DIMENSIONS ARE DETERMINED AT THE SEATING PLANE, DATUM A.

© FREESCALE SEMICONDUCTOR, INC. ALL RIGHTS RESERVED.	<b>MECHANICAL OUTLINE</b>	PRINT VERSION NOT TO SCALE	
TITLE: 144 LEAD LQFP 20 X 20, 0.5 PITCH, 1.4 THICK	DOCUMENT NO: 98ASS23177W	REV: F	
	CASE NUMBER: 918-03	20 MAY 2005	
	STANDARD: NON-JEDEC		

**Figure 42. LQFP144 Mechanical Drawing (Part 3 of 3)**

### 3.18 176 LQFP

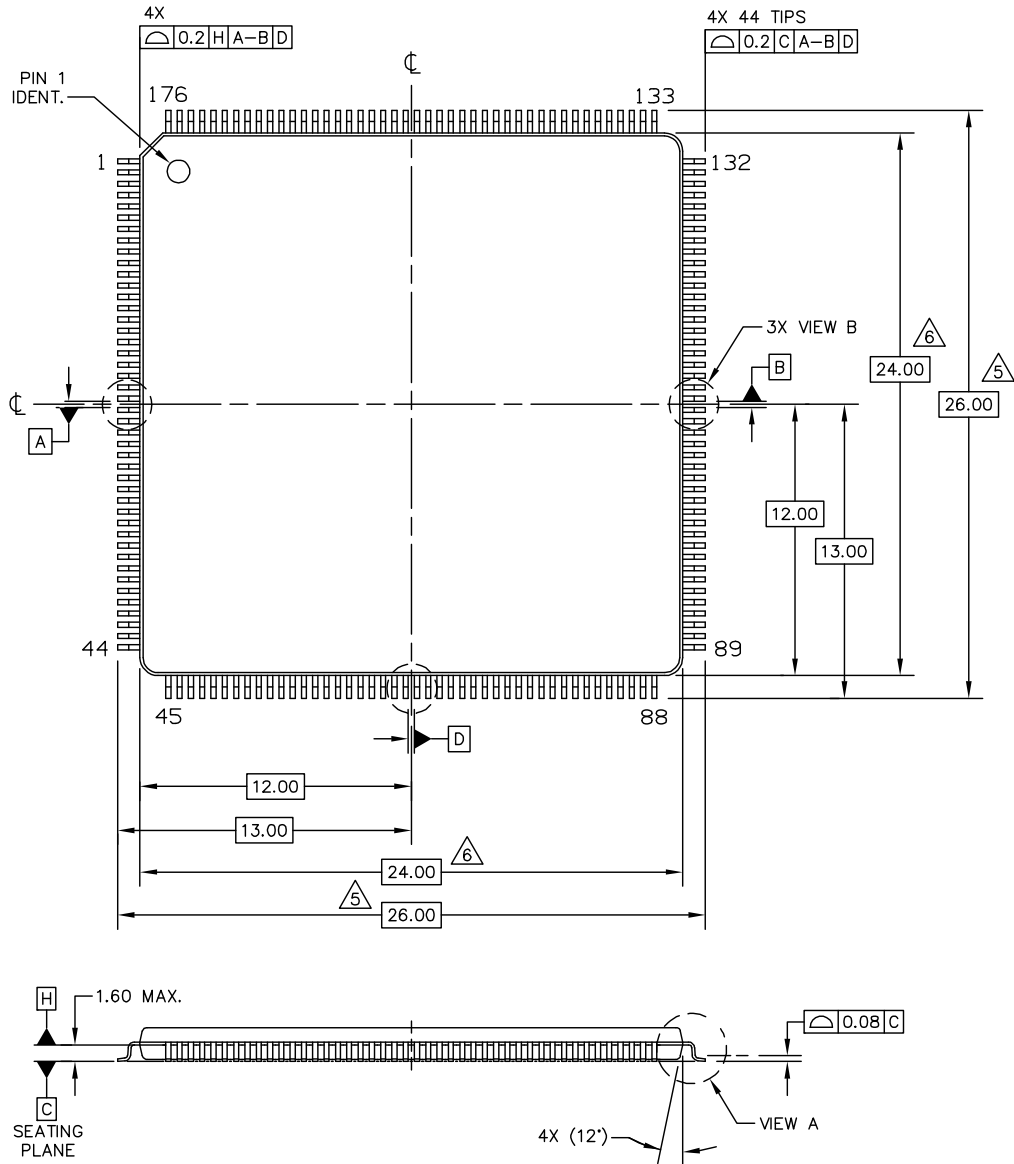

© FREESCALE SEMICONDUCTOR, INC. ALL RIGHTS RESERVED.	<b>MECHANICAL OUTLINE</b>	PRINT VERSION NOT TO SCALE	
TITLE: 176 LD TQFP, 24 X 24 PKG, 0.5 PITCH, 1.4 THICK	DOCUMENT NO: 98ASS23479W	REV: B	
	CASE NUMBER: 1101-01	02 JUN 2005	
	STANDARD: JEDEC MS-026 BGA		

Figure 43. LQFP176 Mechanical Drawing (Part 1 of 3)

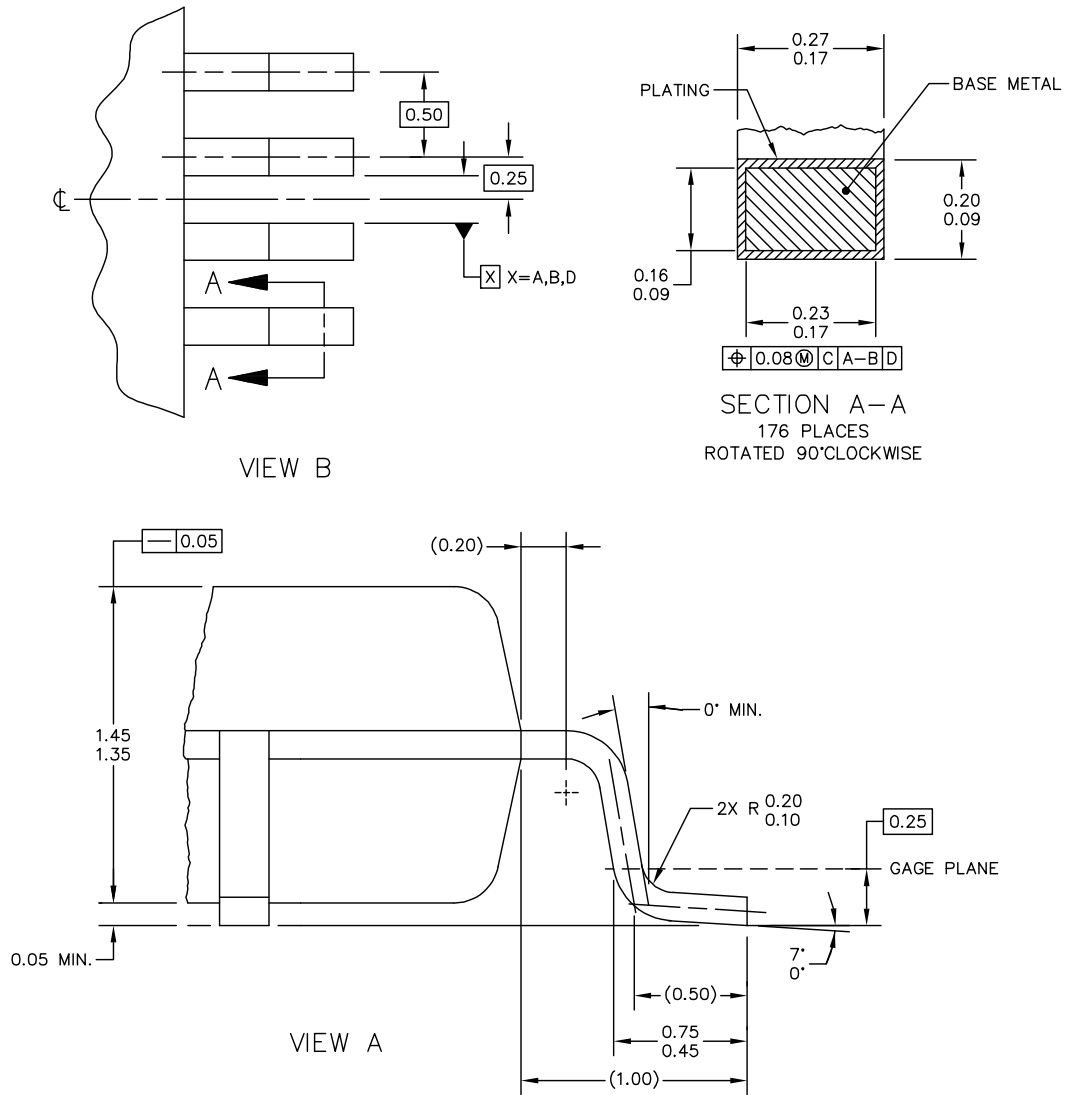

© FREESCALE SEMICONDUCTOR, INC. ALL RIGHTS RESERVED.	<b>MECHANICAL OUTLINE</b>	PRINT VERSION NOT TO SCALE	
TITLE: 176 LD TQFP, 24 X 24 PKG, 0.5 PITCH, 1.4 THICK	DOCUMENT NO: 98ASS23479W	REV: B	
	CASE NUMBER: 1101-01	02 JUN 2005	
	STANDARD: JEDEC MS-026 BGA		

Figure 44. LQFP176 Mechanical Drawing (Part 2 of 3)

NOTES:

- 1 DIMENSIONS AND TOLERANCING PER ASME Y14.5M-1994.
- 2 DIMENSIONS IN MILLIMETERS.
- 3 DATUM PLANE H IS LOCATED AT BOTTOM OF LEAD AND IS COINCIDENT WITH THE LEAD WHERE THE LEAD EXITS THE PLASTIC BODY AT THE BOTTOM OF THE PARTING LINE.
- 4 DATUMS A, B AND D TO BE DETERMINED AT DATUM PLANE H.
- 5 THIS DIMENSIONS TO BE DETERMINED AT SEATING PLANE, DATUM C.
- 6 THIS DIMENSIONS DO NOT INCLUDE MOLD PROTRUSION. ALLOWABLE PROTRUSION IS 0.25 PER SIDE. THIS DIMENSIONS INCLUDE MOLD MISMATCH AND ARE DETERMINED AT DATUM PLANE H.
- 7 THIS DIMENSION DOES NOT INCLUDE DAMBAR PROTRUSION. DAMBAR PROTRUSION SHALL NOT CAUSE THE LEAD WIDTH TO EXCEED 0.35. MINIMUM SPACE BETWEEN PROTRUSION AND ADJACENT LEAD 0.07.

© FREESCALE SEMICONDUCTOR, INC. ALL RIGHTS RESERVED.	<b>MECHANICAL OUTLINE</b>	PRINT VERSION NOT TO SCALE	
TITLE: 176 LD TQFP, 24 X 24 PKG, 0.5 PITCH, 1.4 THICK	DOCUMENT NO: 98ASS23479W	REV: B	
	CASE NUMBER: 1101-01	02 JUN 2005	
	STANDARD: JEDEC MS-026 BGA		

Figure 45. LQFP176 Mechanical Drawing (Part 3 of 3)

# 4 Ordering Information

Table 45 shows the orderable part numbers for the MPC5606S series.

**Table 45. Orderable Part Number Summary**

Part Number	Flash/SRAM	Package	Speed (MHz)
MPC5602SEMLQ	256 KB/24 KB	144 LQFP	64
MPC5604SEMLQ	512 KB/48 KB	144 LQFP	64
MPC5604SEMLQ	512 KB/48 KB	144 LQFP	64
MPC5606SEMLQ	1 MB/48 KB <sup>1</sup>	144 LQFP	64
MPC5606SEMLU	1 MB/48 KB <sup>1</sup>	176 LQFP	64

<sup>1</sup> Device also includes 160 KB of graphics SRAM.

**Figure 46. Commercial product code structure**

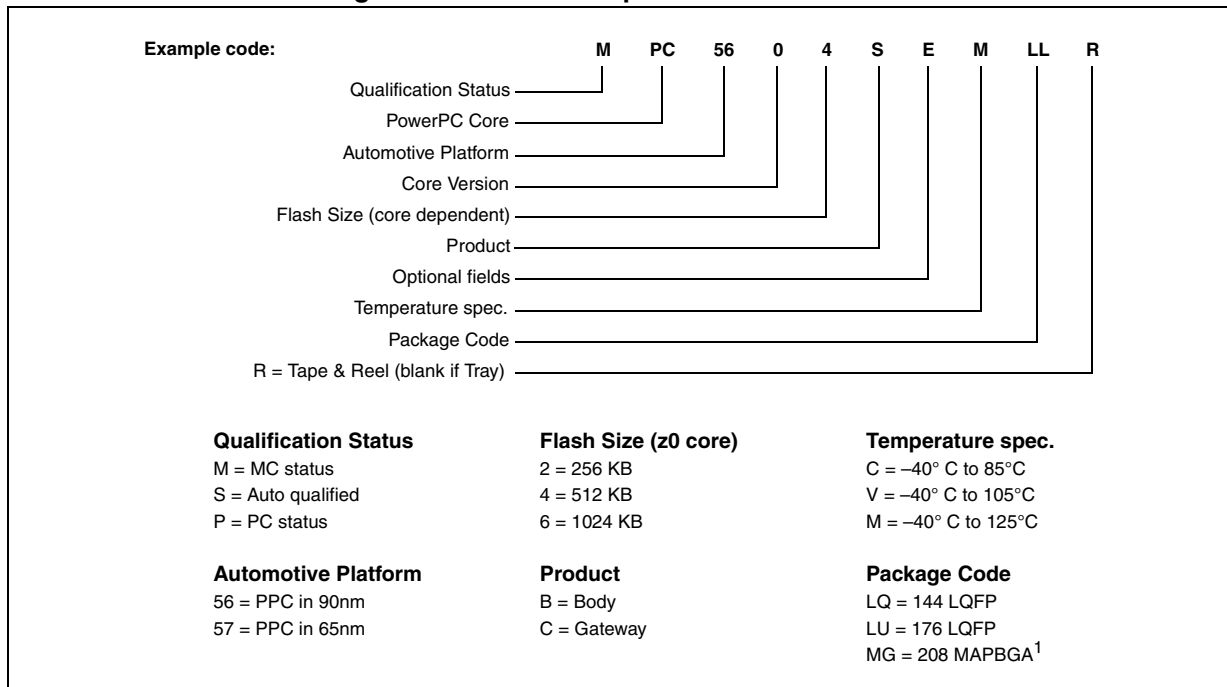

<sup>1</sup> 208 MAPBGA available only as development package for Nexus2+





## How to Reach Us:

### Home Page:

[www.freescale.com](http://www.freescale.com)

### Web Support:

<http://www.freescale.com/support>

### USA/Europe or Locations Not Listed:

Freescale Semiconductor, Inc.  
Technical Information Center, EL516  
2100 East Elliot Road  
Tempe, Arizona 85284  
+1-800-521-6274 or +1-480-768-2130  
[www.freescale.com/support](http://www.freescale.com/support)

### Europe, Middle East, and Africa:

Freescale Halbleiter Deutschland GmbH  
Technical Information Center  
Schatzbogen 7  
81829 Muenchen, Germany  
+44 1296 380 456 (English)  
+46 8 52200080 (English)  
+49 89 92103 559 (German)  
+33 1 69 35 48 48 (French)  
[www.freescale.com/support](http://www.freescale.com/support)

### Japan:

Freescale Semiconductor Japan Ltd.  
Headquarters  
ARCO Tower 15F  
1-8-1, Shimo-Meguro, Meguro-ku,  
Tokyo 153-0064  
Japan  
0120 191014 or +81 3 5437 9125  
[support.japan@freescale.com](mailto:support.japan@freescale.com)

### Asia/Pacific:

Freescale Semiconductor China Ltd.  
Exchange Building 23F  
No. 118 Jianguo Road  
Chaoyang District  
Beijing 100022  
China  
+86 10 5879 8000  
[support.asia@freescale.com](mailto:support.asia@freescale.com)

### For Literature Requests Only:

Freescale Semiconductor Literature Distribution Center  
P.O. Box 5405  
Denver, Colorado 80217  
1-800-441-2447 or 303-675-2140  
Fax: 303-675-2150  
[LDCForFreescaleSemiconductor@hibbertgroup.com](mailto:LDCForFreescaleSemiconductor@hibbertgroup.com)

Document Number: MPC5606S

Rev. 1

10/2008

**Preliminary—Subject to Change Without Notice**

Information in this document is provided solely to enable system and software implementers to use Freescale Semiconductor products. There are no express or implied copyright licenses granted hereunder to design or fabricate any integrated circuits or integrated circuits based on the information in this document.

Freescale Semiconductor reserves the right to make changes without further notice to any products herein. Freescale Semiconductor makes no warranty, representation or guarantee regarding the suitability of its products for any particular purpose, nor does Freescale Semiconductor assume any liability arising out of the application or use of any product or circuit, and specifically disclaims any and all liability, including without limitation consequential or incidental damages. "Typical" parameters that may be provided in Freescale Semiconductor data sheets and/or specifications can and do vary in different applications and actual performance may vary over time. All operating parameters, including "Typicals", must be validated for each customer application by customer's technical experts. Freescale Semiconductor does not convey any license under its patent rights nor the rights of others. Freescale Semiconductor products are not designed, intended, or authorized for use as components in systems intended for surgical implant into the body, or other applications intended to support or sustain life, or for any other application in which the failure of the Freescale Semiconductor product could create a situation where personal injury or death may occur. Should Buyer purchase or use Freescale Semiconductor products for any such unintended or unauthorized application, Buyer shall indemnify and hold Freescale Semiconductor and its officers, employees, subsidiaries, affiliates, and distributors harmless against all claims, costs, damages, and expenses, and reasonable attorney fees arising out of, directly or indirectly, any claim of personal injury or death associated with such unintended or unauthorized use, even if such claim alleges that Freescale Semiconductor was negligent regarding the design or manufacture of the part.

RoHS-compliant and/or Pb-free versions of Freescale products have the functionality and electrical characteristics as their non-RoHS-compliant and/or non-Pb-free counterparts. For further information, see <http://www.freescale.com> or contact your Freescale sales representative.

For information on Freescale's Environmental Products program, go to <http://www.freescale.com/epp>.

Freescale™ and the Freescale logo are trademarks of Freescale Semiconductor, Inc. All other product or service names are the property of their respective owners. The Power Architecture and Power.org word marks and the Power and Power.org logos and related marks are trademarks and service marks licensed by Power.org.

© Freescale Semiconductor, Inc. 2008. All rights reserved.

