



- ▶ Low Profile
- ▶ 2.5 x 2.0 mm Footprint
- ▶ Extended Temp. Range Option
- ▶ RoHS Compliant

# ECX-2236

## SMD CRYSTAL

The miniature ECX-2236 is a very compact SMD Crystal. The 2.5 x 2.0 x 0.55 mm ceramic package is ideal for today's SMD manufacturing environment.

### OPERATING CONDITIONS / ELECTRICAL CHARACTERISTICS

PARAMETERS	CONDITIONS	ECX-2236			UNITS
		MIN	TYP	MAX	
Frequency	Fo	16.000		80.000	MHz
Frequency Tolerance	@ +25°C			± 50 *	ppm
Frequency Stability (ref @ 25°C)	-20 ~ +70°C			± 50 *	ppm
Shunt Capacitance				5.0	pF
Load Capacitance			8		pF
Equivalent Series Resistance	Fundamental Mode			100	Ω
Drive Level				100	μW
Operating Temperature	Topr	-20		+70	°C
Storage Temperature	Tstg	-40		+85	°C
Aging Characteristics (Per Year)	@ +25°C ± 3°C			± 5	ppm

### PACKAGE DIMENSIONS (mm)

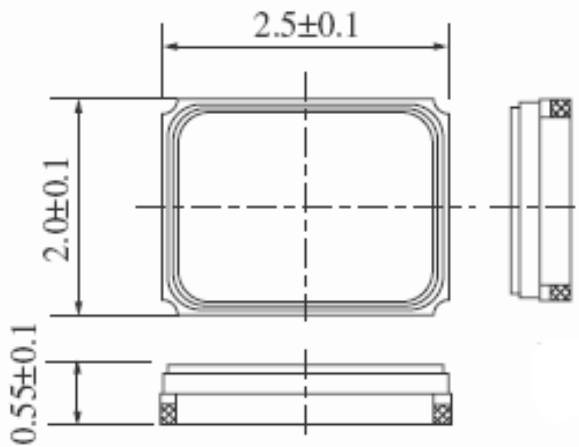

Figure 1) Top, Side and End Views

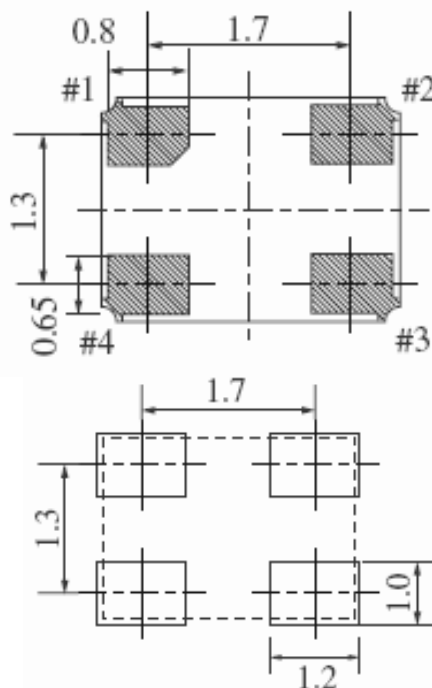
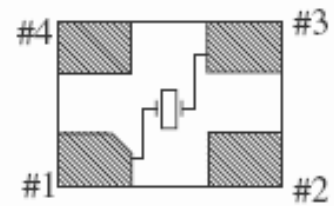

Figure 2) Bottom View and Suggested Land



Pad Connections	
1	In/Out
2	Gnd
3	In/Out
4	Gnd

Figure 3) Internal Connections (Top View)

### PART NUMBERING GUIDE: Example ECS-160-8-36-TR

ECS	- Frequency Abbreviation	- Load	- Package Type	- Tolerance	- Stability	- Temp Range	- Packaging
160	16.000 MHz See P/N Guide for Std Frequencies	8 = 8.0 pF S = Series	-36 = ECX-2236	A = ± 25 ppm C = ± 10 ppm	D = ± 100 ppm E = ± 50 ppm G = ± 30 ppm H = ± 25 ppm K = ± 10 ppm	L = -10 ~ +70°C M = -20 ~ +70°C N = -40 ~ +85°C P = -40 ~ +105°C	-TR = Tape & Reel 1K/Reel

\* Tighter Tolerance/Stability Options Available (see custom options)  
Not all stabilities are available at all temp ranges, consult ECS.



### Developed Frequencies

FREQUENCY MHz	CODE
16.000	160
16.384	163.8
19.200	192
20.000	200
24.000	240
24.576	245.76
25.000	250
26.000	260
27.000	270
30.000	300
32.000	320
36.000	360
40.000	400
44.000	440
48.000	480

Sample P/N: ECS-200-8-36  
 ECS = Mfg Code  
 200 = Frequency Code 20.000 MHz  
 -8 = Load Capacitance 8 pF  
 -36 = Package, ECX-2236

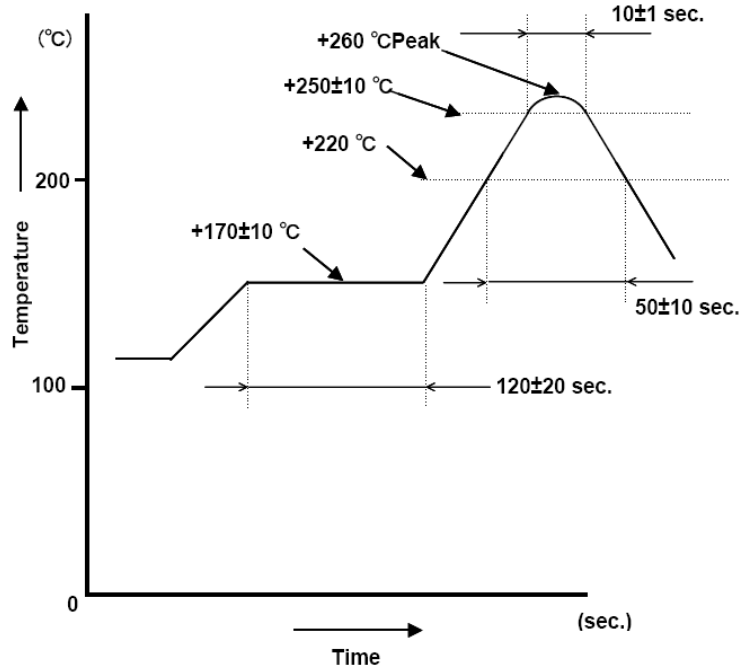
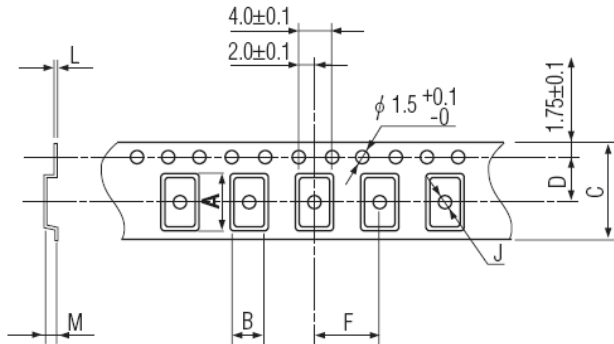

Figure 1) Suggested Reflow Profile

### POCKET TAPE DIMENSIONS (mm)



A	B	C	D	F	J	L	M	Reel Dia.	Qty/Reel
2.8	2.3	8.0	3.5	4.0	1.0	0.25	0.75	180	1000

Figure 2) Pocket Tape Dimensions

Package Data	
Item	Description
Lid	Metal
Base	Ceramic
Sealing	Seam/EB
Terminal	Tungsten (metalized)
Plating	Gold/Nickel Surface/Under
RoHS	Compliant (Pb Free)