

FEATURES

- 0...1500 g range
- High impedance bridge
- Compact, commercial grade package
- Robust performance characteristics
- Ratiometric electrical output
- Extremely low deflection
- High ESD resistance

APPLICATIONS

- Medical infusion pumps
- Ambulatory noninvasive pump pressure
- Occlusion detection
- Kidney dialysis machines
- Load and compression sensing
- Variable tensions control
- Robotic end-effectors
- Wire bonding equipment

SPECIFICATIONS

Maximum ratings

Supply voltage	3..6 V
Temperature limits	
Storage	-40 to +100°C
Operating	-40 to +85°C
Lead temperature (5 sec. soldering)	315°C
Humidity limits	0...99 %RH
Vibration (0 to 2000 Hz) (qualification tested, 0 to 2 KHz)	20 g sine
Mechanical shock (qualification tested)	150 g
Over force ¹	4500 g



Scale: 1 cm
1/2 inch

ELECTRICAL CONNECTION

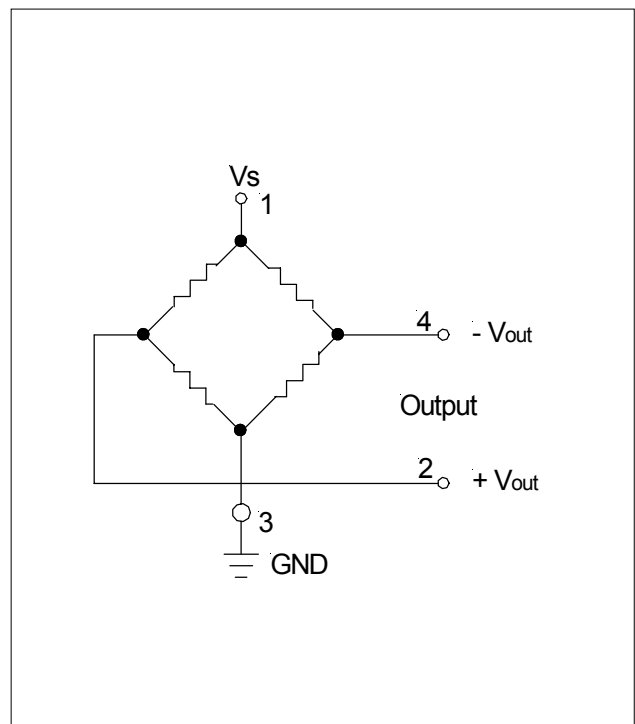

COMMON PERFORMANCE CHARACTERISTICS

$V_s = 5.0 \pm 0.01 \text{ V}$, $t_{amb} = 25^\circ\text{C}$ (unless otherwise noted)

Characteristics	Min.	Typ.	Max.	Unit
Operating force	0		1500	g
Zero pressure offset	-15		+15	mV
Span ²	150	180	210	
Temperature effects (0 - 50°C) ⁴	Offset	±0.5		
	Span		-2200	ppm/°C
Temperature effects on bridge impedance ⁴		+2200		
Linearity (BSL) ³		±0.7	±1.5	% span
Mechanical hysteresis ⁵		±0.5		
Repeatability at 300g ⁵		±1.5		mV
Input impedance	4.0	5.0	6.0	kΩ
Output impedance	4.0	5.0	6.0	
ESD (direct contact, terminals and plunger)	8			kV
MCTF (main cycles to failure at 50°C)		20		million cycles

Specification notes:

1. The maximum specified force which may be applied to the sensor without causing a permanent change in the output characteristics.
2. Span is the algebraic difference between the output voltage at full-scale force and the output at zero force. Span is ratiometric to the supply voltage.
3. Linearity (BSL), the deviation of measured output at constant temperature (25°C) from "Best Straight Line" determined by three points, offset pressure, full-scale pressure and half full-scale pressure.
4. Error band of the offset voltage, span or bridge impedance in the specified temperature range, relative to the 25°C reading.
5. Repeatability, the deviation in output readings for successive application of any given input force (all other conditions remaining constant). Hysteresis, the error defined by the deviation in output signal obtained when a specific force point is approached first with increasing force, then with decreasing force or vice versa (all other conditions remaining constant).

OUTLINE DRAWING

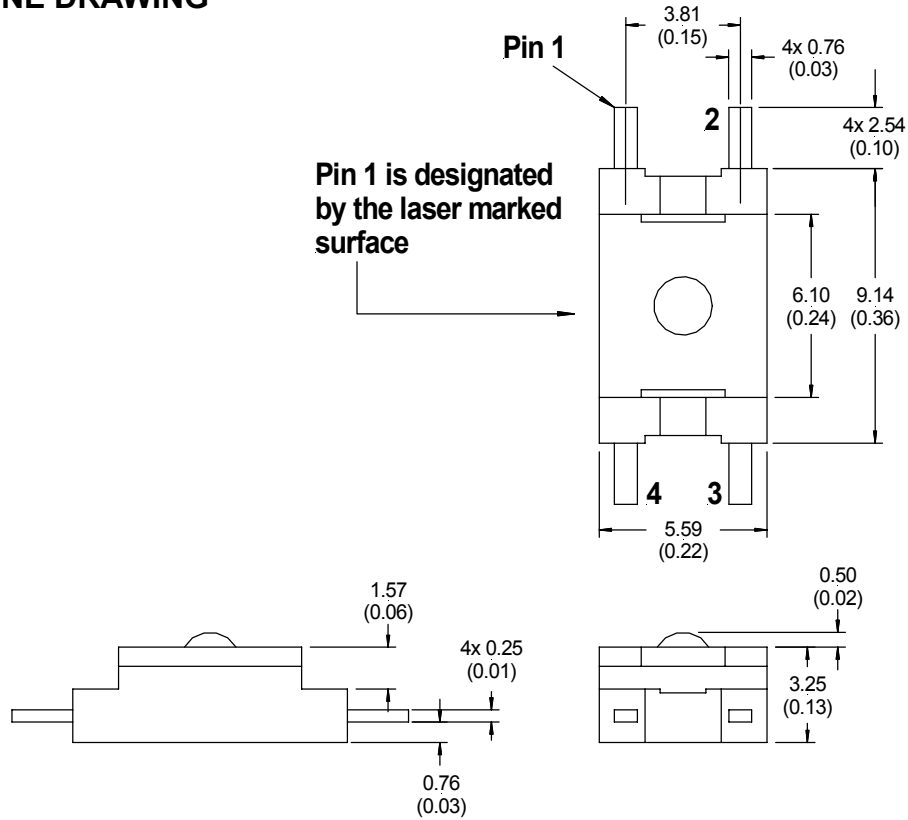

mass: 2 g

dimensions in mm (inches)

ORDERING INFORMATION

PART NO.	PACKAGING STYLE
FSS1500NST	tube (multiples of 100)
FSS1500NSB	blister pack
FSS1500NSR	tape and reel (multiples of 1500)

Sensortech reserves the right to make changes to any products herein. Sensortech does not assume any liability arising out of the application or use of any product or circuit described herein, neither does it convey any license under its patent rights nor the rights of others.